

G. D. JONES.  
Cube Sugar-Machine.

No. 169,004.

Patented Oct. 19, 1875.

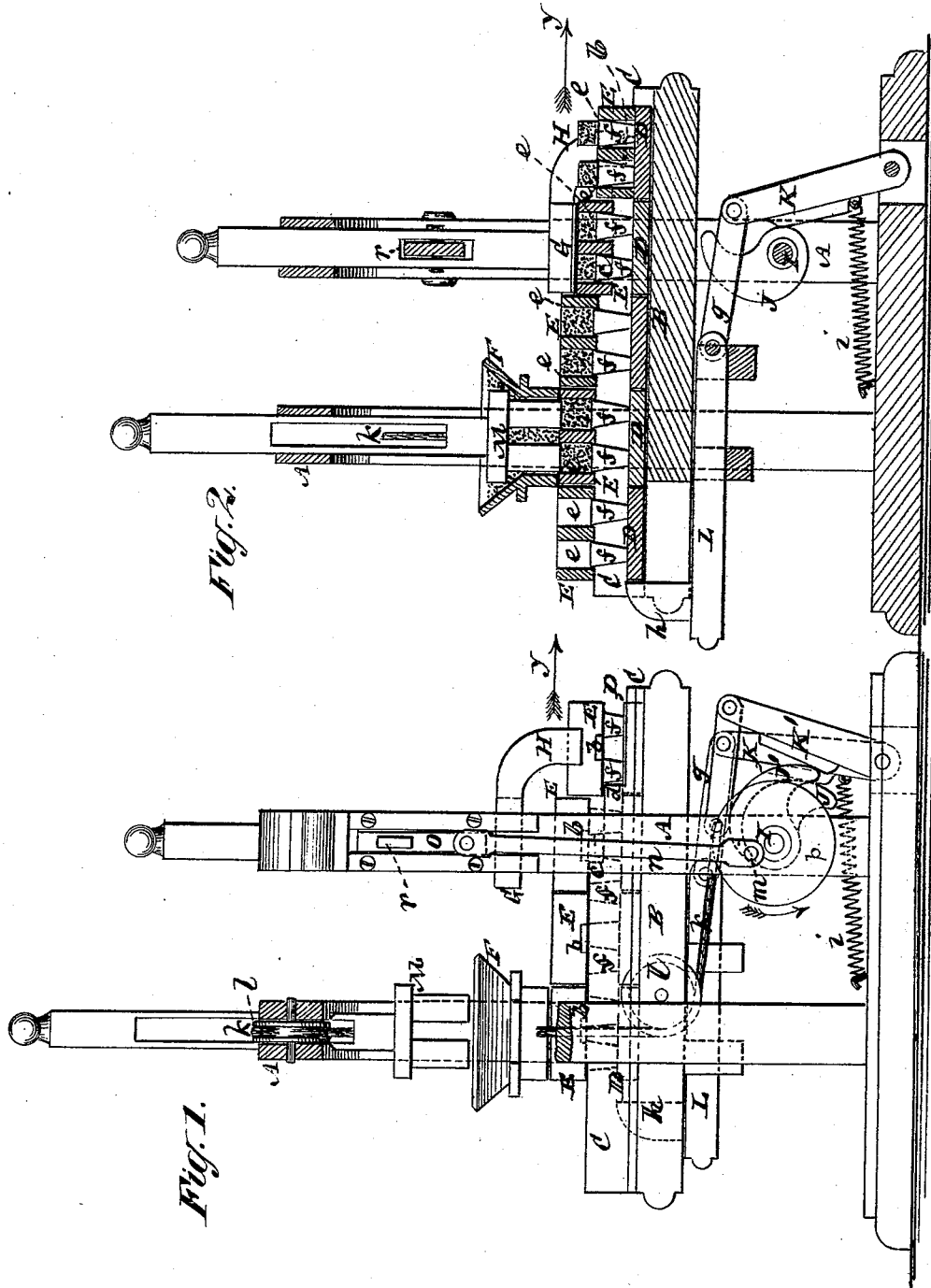

Fig. 2.

Fig. 1.

Witnesses  
 John Decker.  
 Fred. Haynes

G. D. Jones  
 by his Attorneys  
 Brown & Allen

G. D. JONES.  
Cube Sugar-Machine.

No. 169,004.

Patented Oct. 19, 1875.

Fig. 6.

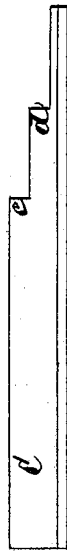

Fig. 4.

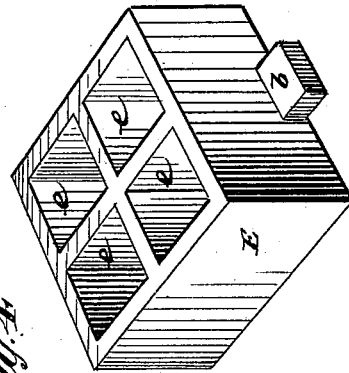

Fig. 5.

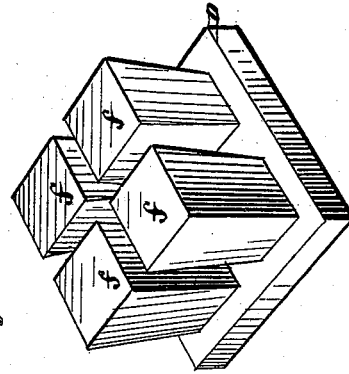
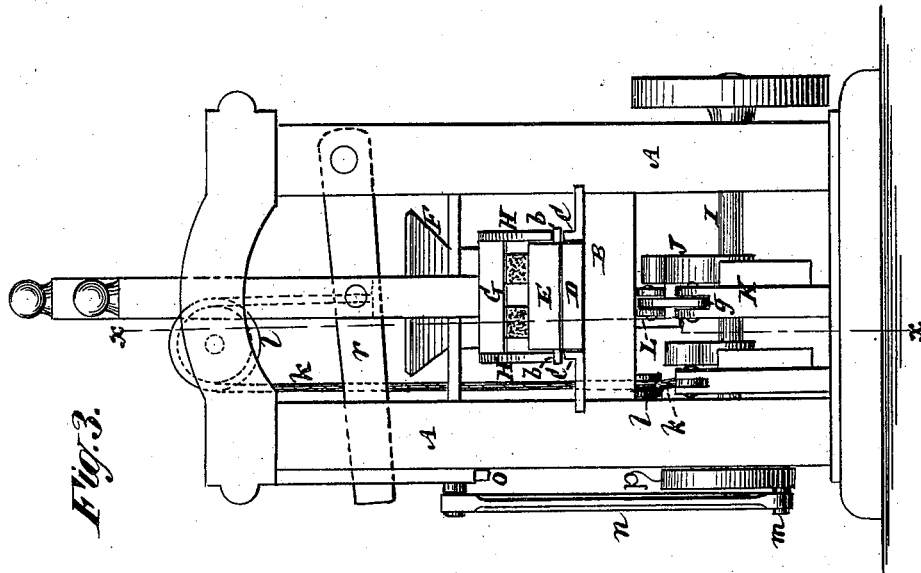

Fig. 3.



Witnesses  
John Becker  
Fred. Wagners

G. D. Jones  
by his Attorneys  
Rowntree & Allen

# UNITED STATES PATENT OFFICE.

GILBERT D. JONES, OF BROOKLYN, ASSIGNOR OF ONE-HALF HIS RIGHT TO ALBERT DE LA MONTAGNIE, OF NEW YORK, AND DAVID ELSTON, OF BROOKLYN, NEW YORK.

## IMPROVEMENT IN CUBE-SUGAR MACHINES.

Specification forming part of Letters Patent No. 169,004, dated October 19, 1875; application filed August 30, 1875.

*To all whom it may concern:*

Be it known that I, GILBERT D. JONES, of the city of Brooklyn, in the county of Kings and State of New York, have invented certain new and useful Improvements in Machines for Making Cube Sugar; and I do hereby declare that the following is a full, clear, and exact description of the same, reference being had to the accompanying drawing, which forms part of this specification.

This invention relates to machines for transforming loose granular sugar into solid cubes or blocks by means of a series of mold-frames divided into compartments corresponding with the shape and size of the cubes or blocks to be made, said mold-frames having a sliding action under a filling-hopper, and acting conjointly with plungers to compact the sugar into shape, and to give it the required solidity. My means for accomplishing the desired result, however, essentially differ from those to be found in other machines for a like purpose, and I am enabled not only to do the work rapidly and with the most perfect regularity as regards the shape and solidity of the cubes or blocks produced, but all sticking of the sugar in the molds is prevented. To these and other ends the invention consists in certain novel combinations of mold-frames, guides, or rails, along which said mold-frames intermittently travel, plunger-frames, which fit the mold-frames and move along with them, a platen operating on the mold-frames to compact the sugar previously fed into them, and a drop or discharger also acting in a like direction on the mold-frames to bring the molded sugar to the surface, and causing the molds to free themselves by their passage over the plungers.

Figure 1 represents a side view of a machine embracing my improvements with a portion of the frame broken away; Fig. 2, an irregular longitudinal vertical section of the same on the line *x x* of Fig. 3; Fig. 3, a front view; Fig. 4, a view in perspective of one of the mold-frames detached; and Fig. 5, a view in perspective of a corresponding plunger-frame; Fig. 6, a longitudinal view of one of the rails.

A is the main frame, which may be of any suitable construction, and B the working-bed or table of the machine. C C are parallel raised ways or rails mounted on the table in direction of its length, and arranged at suitable distances apart to receive freely in between them a succession of plunger-frames, D. The upper edges of these rails serve to carry the mold-frames E by means of projections or ears *b b* on the sides of said frames. Said rails are of varying depth, being formed with steps *c d* near the back or delivery end of the machine, whereby the rails are of consecutively diminishing heights toward the discharging-end of the machine, for a purpose which will be hereinafter explained.

Although the mold-frames E and plunger-frames D are here shown as constructed to produce four cubes only at a time—that is, each mold-frame with its corresponding plunger-frame—it is designed in practice to enlarge their capacity by increasing the size of the mold-frames and dividing them up into a greater number of compartments, *e*, and correspondingly increasing the number of followers *f* of each plunger-frame, and modifying other portions of the apparatus to suit.

The molds or mold-frames E are open top and bottom, the plunger-frames D with their attached plungers forming loose bottoms to the molds, and the plungers *f* entering freely within the compartments *e*, or rather the divided mold-frames dropping freely over said plungers.

In the working of the machine the mold-frames E, together with their plunger-frames D, are arranged in succession, one behind the other, and are intermittently fed or slid forward along or over the bed—that is to say, the plunger-frames D traveling on the bed B between the rails C C, while the mold-frames E travel by their ears or projections *b* on the rails. This intermittent travel of the mold-frames and plunger-frames in direction of the arrow *y* serves to bring each mold-frame in succession first under a filling hopper or box, F, then under a compressing-platen, G, and lastly, under a discharger, H. The action of

these last-named devices will be hereinafter more fully explained.

I is a revolving main or driving shaft, on which is a cam, J, that acts on a rocker, K, which, in its turn, is connected by a rod, *g*, with a longitudinal slide, L. This slide is provided with a head, *h*, at its outer end, arranged to pass through a longitudinal slot in the rear end of the bed B between the rails, whereby said slide, when operated by the cam J, acts upon the rear plunger-frame D to give the string or series of mold-frames E, with their respective plunger-frames, an intermittent feed forward. Such slide L consequently is the intermittent driver of the mold and plunger frames, and after each forward stroke or feed it is thrown back by means of a spring, *i*, which acts alternately with the cam J, and when thus thrown back space is provided in rear of the mold-frame E last fed forward under the filling-hopper F for the introduction of a new or empty mold-frame and plunger-frame to match, whereby a continuity of duty on part of the machine may be kept up, a discharged mold-frame with plunger-frame at the same time passing off at the other end of the machine.

On the shaft I is also another cam, J', which operates against a rocker, K', that has connected with it a rope or chain, *k*, which passes around suitable guide-pulleys *l*, and is attached at its other end to a filler, M. This filler may have projections on its face corresponding with the compartments *e* in the mold-frames, and it is fitted to rise and fall at intervals within the filling-hopper F, for the purpose of allowing the replenishing of the hopper with loose granular sugar, and for the passing of said sugar into the mold-frames E as they are successively brought under the filling-hopper. The cam J' operates to lift said filler M, which drops when released from such action by the cam, and urges the sugar down from or through the bottom of the hopper into the mold-frame beneath. The shaft I also serves, by means of a crank-pin, *m*, on wheel *p*, rod *n*, slide *o*, and lever *r*, or other suitable devices, to give an up-and-down reciprocating motion to the platen G and discharger H. Said discharger H is here shown as formed by forwardly and downwardly projecting arms, attached to the platen, so as to operate in concert with it, and whereby the one set of actuating devices serve to operate both the compressing platen and the discharger; but, if preferred, the discharger may be operated by devices other than those used to operate the platen.

In the general operation of the machine each mold-frame of the series of mold-frames E is brought in succession under the filling-hopper F, the followers *f* of the plunger-frames D then only entering within the bottoms of the compartments *e* of the mold-frames by reason of the ears *b* of the mold-frames then resting on and traveling along the highest portions of the rails C C, while their plunger-frames D rest on and travel along the bed B.

The slide or driver L is the intermittent propelling agent of the mold and plunger frames, as hereinbefore described.

As said molding-frames with their plunger-frames in succession come under the filling-hopper F, the filler M, having been previously raised, comes down and urges or forces the loose granulated sugar from the hopper into the mold-frame, but is not designed to compress it therein. The mold-frame thus packed with sugar is then—that is, by the next intermittent forward feed or stroke of the slide L—passed from under the filling-hopper, and in due course, as, for instance, by a succeeding intermittent forward feed, is brought under the platen G when raised, but not until the ears or lateral projections *b* of such mold-frame have passed over the first steps or reductions *c* in the rails, so that when the platen G comes down it will force the mold-frame to a sufficient extent down or over the followers *f* of the plunger-frame, which fits said mold-frame, as to insure the sugar being compressed to a sufficient extent within the mold-frame.

The platen G may be enameled on its face to prevent the sugar sticking to it and to provide, during the next intermittent forward feed of the series of mold-frames and their respective plunger-frames, for the mold-frame, which has had the sugar in it, subjected to compression, as described, passing in a smoothing or leveling manner under the platen, and from thence down over the second step *d* in the rails C, so that when the discharger H comes down and acts upon the ears *b* it will force said mold-frame still farther down over the followers *f* of its plunger-frame till the tops of the followers are on a level with the upper surface of the mold-frame, thus discharging the sugar by causing the molds or mold-frames to free themselves, and so that the sugar is discharged in the same direction that it was compressed. This action, which is clearly represented in Fig. 2, is repeated for each mold-frame in succession, and by it all sticking and irregularity are prevented, and perfect blocks or cubes of sugar are produced.

After the sugar has been discharged from the mold-frames by the latter freeing themselves, as described, said sugar may readily be transferred by an endless belt or conveyer to any suitable drying oven or room.

I claim—

1. The combination of the molds or mold-frames E with the plunger-frames D or their plungers *f* and the platen G, whereby the molds and platen descend in concert for the purpose of compressing the sugar, and said molds afterward farther descend, without the platen, to effect the discharge of the sugar, substantially as specified.

2. The combination of the intermittently-traveling mold-frames E and plunger-frames D with the bed B, rails C C, and a filling-box or hopper, F, essentially as described.

3. The combination of the intermittently-

operating slide or driver L with the series of mold-frames E and plunger-frames D, the surface or bed B, on which the plunger-frames travel, and the rails C, on which the mold-frames slide, substantially as specified.

4. The mold-frames E, constructed or provided with ears or lateral projections *b b*, in combination with the rails C C having steps *c d* in them, essentially as described.

5. The combination of the platen G with the rising and falling mold-frames E, the rails C having a step, *c*, in them, and the plunger-frames D, substantially as specified.

6. The combination of the discharger H with the mold-frames E, the rails C having a step, *d*, in them, and the plunger-frames D, essentially as described.

7. The platen G, having the discharger H attached to it for simultaneous operation on successive or adjacent mold-frames E in a like direction, and in opposition to the plunger-frames D, as herein set forth.

8. The combination of the filler M, the filling-hopper F, the platen G, the discharger H, the mold-frames E, the plunger-frames D, the bed B, the stepped rails C C, and the intermittent slide or driver L, substantially as specified.

GILBERT D. JONES.

Witnesses:

HENRY T. BROWN,

MICHAEL RYAN.