

W. MUIR.
Hatchway-Guard.

No. 169,025.

Patented Oct. 19, 1875.

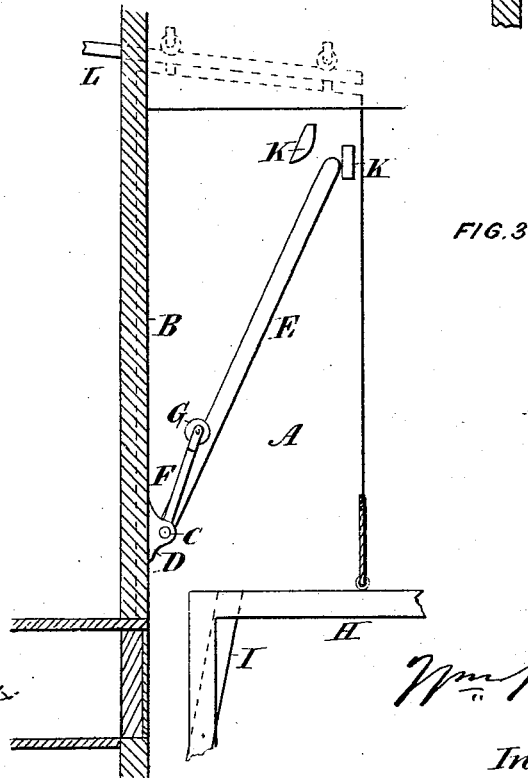
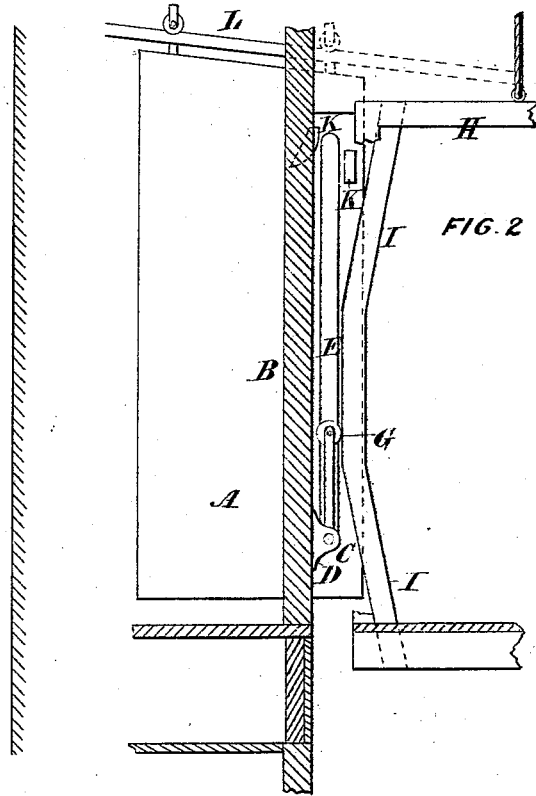
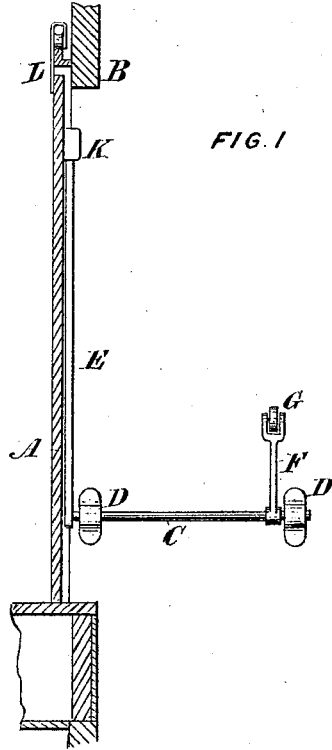

Witnesses:
Tracy Reynolds
S. J. Kerr.

Wm. Muir
 Inventor

W. MUIR.
Hatchway-Guard.

No. 169,025.

Patented Oct. 19, 1875.

FIG. 4

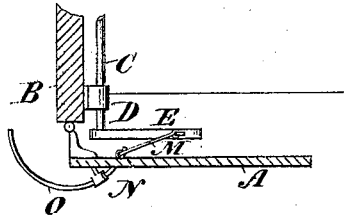

FIG. 5

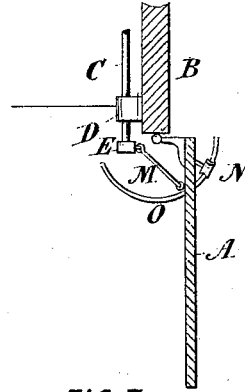

FIG. 6

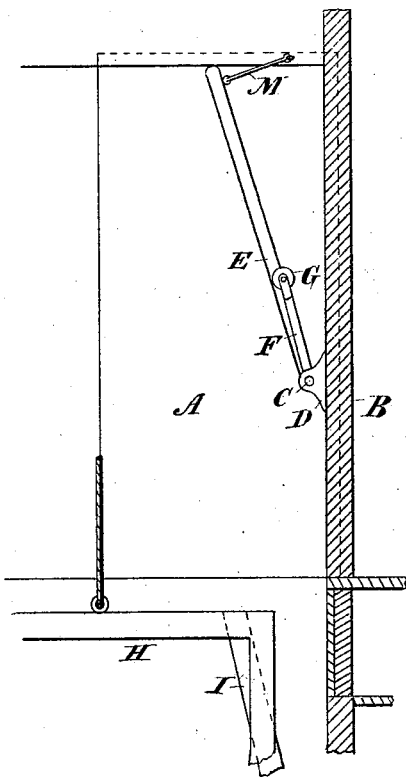
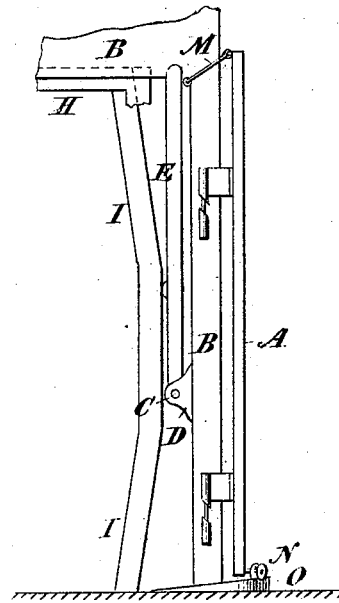

FIG. 7



Witnesses
Francis Reynolds
S. J. Keen

Wm¹⁰ Muir
Inventor

UNITED STATES PATENT OFFICE

WILLIAM MUIR, OF MONTREAL, CANADA.

IMPROVEMENT IN HATCHWAY-GUARDS.

Specification forming part of Letters Patent No. 169,025, dated October 19, 1875; application filed March 19, 1875.

CASE A.

To all whom it may concern:

Be it known that I, WILLIAM MUIR, of the city of Montreal, in the district of Montreal and Province of Quebec, Canada, have invented certain new and useful Improvements in Hoistways; and I do hereby declare that the following is a full, clear, and exact description of the same.

My invention has reference particularly to hoistways in which the doors on the several floors act by sliding back, sidewise, or by swinging outward; and consists in an apparatus by which these doors are opened and closed by the upward or downward passage of the traveling cab or platform, the doors in each story being kept closed, except when the platform is just below, at the level of, or at a short distance above, the floor, thus entirely obviating any chance of those accidents from falling down hoistways, which are now so common, and, by assuring the automatic closing of the doors, doing away with the objections to hoistways on account of the increased risk of fire from its communication from a lower story to the upper flats.

For fuller comprehension of my invention, reference must be had to the drawings hereunto annexed, in which similar letters of reference indicate like parts, and where—

Figure 1 is a sectional elevation, looking toward the side, of a hoistway provided with sliding doors. Fig. 2 is a detail section, showing the hoistway with the doors open. Fig. 3 is a similar section with the doors shut. Fig. 4 is a part plan of a hoistway with doors opening outward, showing the doors shut. Fig. 5 is a modification with doors open. Fig. 6 is a part sectional elevation of the same with doors shut. Fig. 7 is a part elevation of outside of the same showing doors open.

A A are the doors, and B the framing of the well or hoistway, on the sides of which are placed, as shown in Figs. 1, 4, and 5, rock-shafts C C, carried in proper bearings D D, to the outer ends of these rock-shafts being secured levers E E, to be hereinafter more particularly alluded to. Arms F, forked at their free ends to receive rollers G, are firmly secured, as shown in Fig. 1, to the rock-shafts

C. The ends of these arms F may, instead of being forked and furnished with rollers, be made rounded or beveled, so as to produce the same effect—*i. e.*, the diminution of friction. H is the traveling cab or platform, operated by any ordinary power, and having arranged on either side pieces I I, inclining inward at both ends, and acting upon the rollers G, as will be hereinafter described. Where the doors of the hoistway are those which slide back and forth, the levers E E engage at their free ends with stops K K, secured, as shown in Figs. 1, 2, and 3, to the doors A A, which in this instance are preferably hung (by means of straps and rollers) from the rail L, set with a fall inward. In hoistways where the doors open outward, an eye or hook is secured to the ends of the levers E, as shown in Figs. 6 and 7, to which is loosely attached a rod or arm, M, fastened at its other end to an eye on the door A, both of these being hinged to the framing, as shown, or by any means which will allow the door in opening to rise up, the lifting being effected by means of a roller, N, attached to each door, and running, as it opens, upon a rail, O, forming the segment of a circle, and sloped up from its inner to its outer end.

The operation of my invention is as follows: The doors of the hoistway being closed, as in Figs. 3 and 5, and the respective parts in the positions there shown, the traveling platform H rises or descends until the inclined pieces I come in contact with the rollers G on the ends of the levers, or their equivalents, pressing them back until they are brought into the positions shown in Figs. 2 and 7, thus raising the levers E, which, when the doors are those which slide, act upon the stops K, and force the doors back, holding them open as long as the pressure of the pieces I continues against the levers or arms F. As soon as this is withdrawn by the further ascent or descent of the platform H, the weight of the doors causes them to run down the rails L and come together, a strip of india-rubber or other like substance being provided to act as a buffer. Where the doors swing outward, the levers E, in rising, act by means of the arms L upon

the doors, forcing them outward till they assume the position shown in Figs. 5 and 7. As soon as the pressure on the rollers G or ends of the arms F is removed the doors run round on the curved rail O and come together, closing the hoistway-opening.

It will be observed that the above devices, in addition to being very cheaply put up and perfectly efficient, can be applied to any hoist, by whatever power it may be worked, and can be fixed in hoists already built without in any way interfering with existing arrangements.

I do not claim any device for operating the traveling platform, or for regulating its motion, or for securing it in case of accidents; but What I claim as my invention is as follows:

1. In combination with any hoistway provided with sliding doors, the rock-shaft C, carrying lever E, engaging with stops K, and arm F, with or without roller G, acted upon by inclined planes I, substantially as and for the purposes set forth.

2. The combination of the rock-shaft C with arm F and lever E, acted upon by the traveling platform H, and imparting motion to the doors A of the hoistway, as and for the purpose specified.

Montreal, 23d day of January, A. D. 1875.
WM. MUIR.

Witnesses:

FRAS. HY. REYNOLDS,
S. J. KERR.

[Faint, mostly illegible text, likely bleed-through from the reverse side of the page.]

[Faint, mostly illegible text, likely bleed-through from the reverse side of the page.]