

G. A. NAUMANN.
Joiners' Clamps.

No. 169,027.

Patented Oct. 19, 1875.

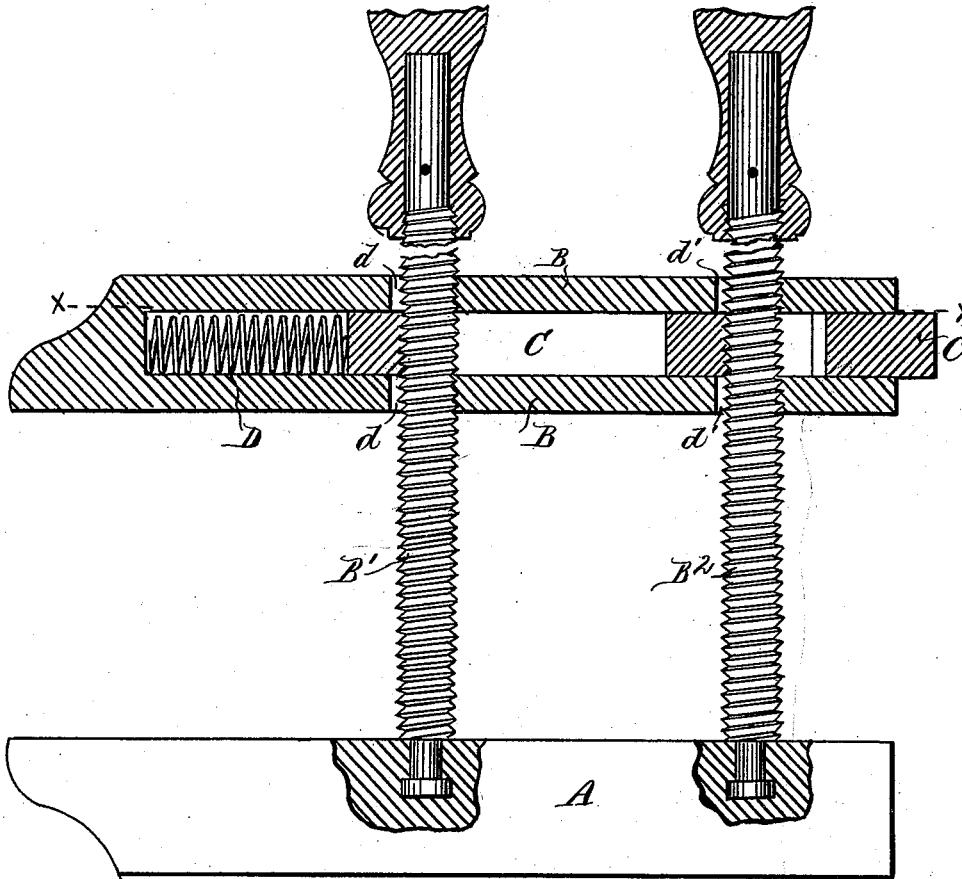

Fig. 1.

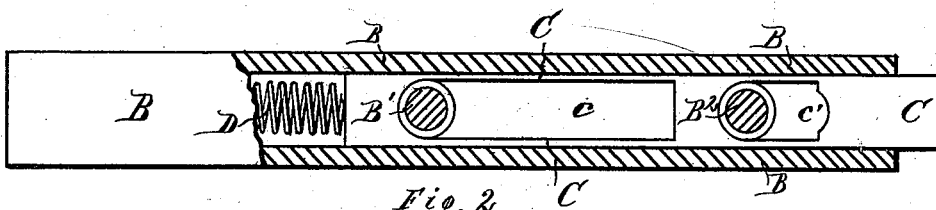

Fig. 2.

Witnesses:
Chas. A. Meiner,
J. H. Kerthel.

Inventor:
Gustav Adolph Naumann
per Kerthel & Co

Atty.

UNITED STATES PATENT OFFICE

GUSTAV A. NAUMANN, OF ST. LOUIS, MISSOURI.

IMPROVEMENT IN JOINERS' CLAMPS.

Specification forming part of Letters Patent No. **169,027**, dated October 19, 1875; application filed September 6, 1875.

To all whom it may concern:

Be it known that I, GUSTAV ADOLPH NAUMANN, of St. Louis, Missouri, have invented an Improved Joiner's Clamp, of which the following is a specification:

The ordinary clamp-screw consists of jaws or holders operated by wooden hand-screws reversely positioned, so that, to adjust and use the jaws or clamps for holding work, it is necessary to turn both screws in opposite directions. This to do, in large clamp-screws, more especially, is very difficult; also, said screws project in opposite directions, rendering the device inconvenient, cumbersome, and difficult for operating, turning, or handling; nor can the device holding the work be laid down or positioned in accordance with the position best suited to the nature of the work. All this to avoid is the object of my improvement; and it consists in the novel construction and combination of its parts in manner now to be more fully described.

Of the drawing, Figure 1 is a sectional elevation. Fig. 2 is a plan section of the movable jaw on line *x x*.

A is the fixed jaw, constructed as ordinary. B is the movable jaw. B¹ B² are the hand-screws. The hand-screws I have both positioned alike, both running through the upper jaw B, and both secured in the fixed jaw A, as shown in Fig. 1. To dispense with the constant screwing together and apart of the jaws, I make the movable jaw B capable of being brought toward or away from the jaw A by sliding on the screws. This I accomplish as follows: The jaw B I make hollow almost its entire length. (See Figs. 1 and 2.) In its hollow is a slide, C, which is made of the constructive shape shown in Fig. 2, having slots *c c'*, for the double purpose of allowing the screws B¹ B² to pass through, as well as to lighten the weight of the slide. The back sides of the slots *c c'* have threads cut in them, (see Fig. 1,) to engage the threads of the hand-screws, and are held in engagement with the latter by a spring, D, inserted behind the

slide. (See figures.) Similarly I provide the opposite sides of the slots *d d'* of the jaw B with screw-threads, indicated in Fig. 1.

The tension of the spring pressing the slide against the screws, at the same time holds the screws against the opposite threaded sides of the openings *d d'*. The slide being in the position just described, by simply turning the screws the clamp is operated to clamp the work held.

When the clamp is to be adjusted from wide to narrow, or vice versa, the end of the slide projecting out at the back of the jaw B is pressed in by the operator, which compresses the spring, and disengages the threaded sides of the slide from the hand-screws, and said screws from the threads in the upper jaw, and thus said jaw is capable of being adjusted as the nature of the work requires. As soon as the operator's hold on the slide is released, the spring restores said slide in original engagement with the hand-screws.

The screws B¹ B² I prefer making of metal, having the threads thereof running reversely, (see Fig. 1,) so that the engagement described with the threads in the jaw B, as well as slide C, can be had. Also, the slide is of metal. The device is, therefore, durable, cheap, and its advantages over ordinary clamps of this character apparent.

What I claim is—

The combination of the movable jaw B, carrying the slide C, having slots *c c'*, the spring D, the hand-screws B¹ B², having bearing-surface of threads reversed, all said parts being constructed and arranged to operate with relation to each other and a fixed jaw, A, substantially as is herein shown and described, and for the purpose set forth.

In testimony of said invention I have hereunto set my hand.

GUSTAV ADOLPH NAUMANN.

Witnesses:

WILLIAM W. HERTHEL,
CHAS. F. MEISNER.