

S. J. CROCKETT.

Octave Coupler for Organs, &c.

No. 169,089.

Patented Oct. 26, 1875.

Fig. 1.

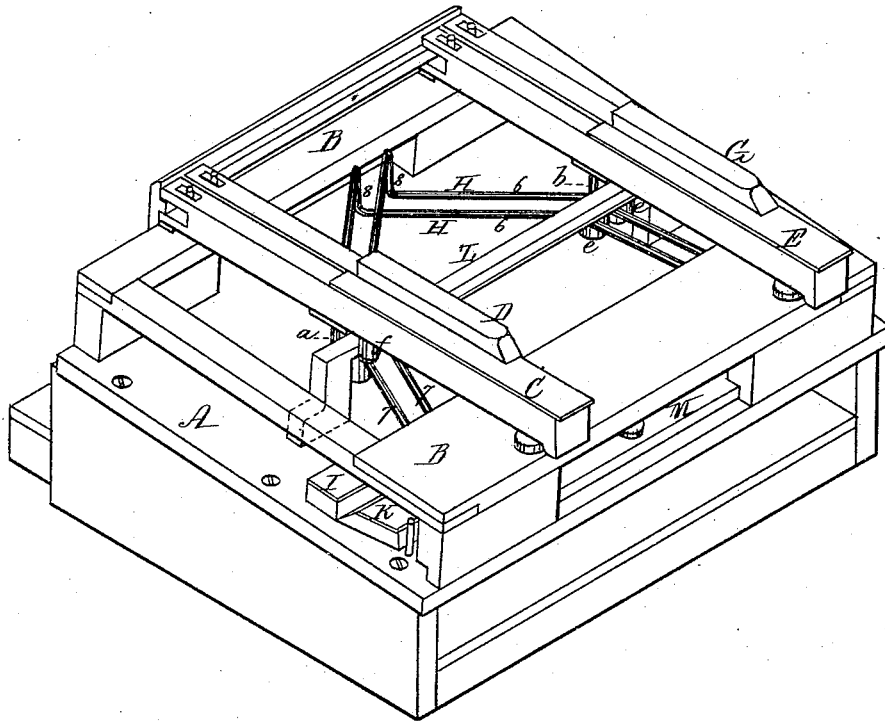
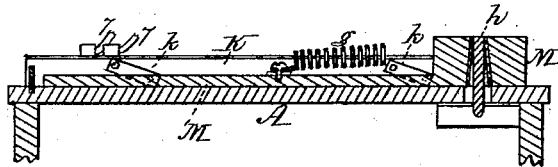

Fig. 4.



Witnesses,
 W. J. Cambridge
 A. J. Carwell

Inventor,
 Samuel J. Crockett
 Per [Signature]
 et

S. J. CROCKETT.
Octave Coupler for Organs, &c.

No. 169,089.

Patented Oct. 26, 1875.

Fig. 2.

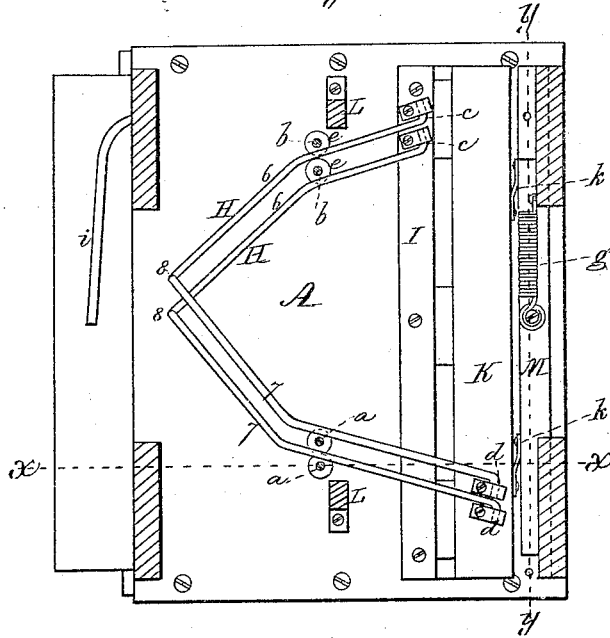

Fig. 3.

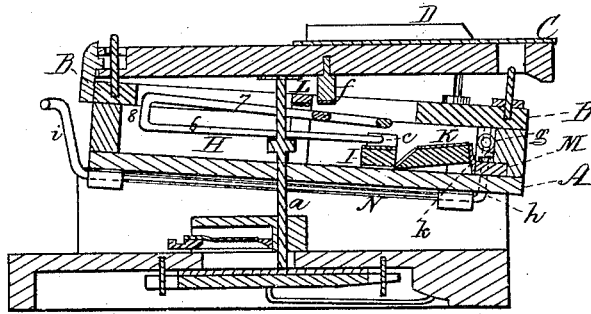
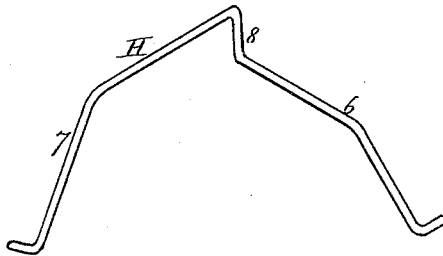

Fig. 5.



Witnesses,
W. J. Cambridge
A. J. Caswell

Inventor,
Samuel J. Crockett
Per Jeremiah Stearns

UNITED STATES PATENT OFFICE.

SAMUEL J. CROCKETT, OF BOSTON, MASSACHUSETTS, ASSIGNOR TO GEORGE T. McLAUGHLIN AND THOMAS F. SCANLAN, OF SAME PLACE.

IMPROVEMENT IN OCTAVE-COUPLERS FOR ORGANS, &c.

Specification forming part of Letters Patent No. 169,089, dated October 26, 1875; application filed August 4, 1875.

To all whom it may concern:

Be it known that I, SAMUEL J. CROCKETT, of Boston, in the county of Suffolk and State of Massachusetts, have invented certain Improvements in Octave-Couplers for Reed-Organs and other musical instruments, of which the following is a full, clear, and exact description, reference being had to the accompanying drawings, making part of this specification, in which—

Figure 1 is a perspective view of a portion of a reed-organ having my improved octave-coupler applied thereto. Fig. 2 is a horizontal section through the same. Fig. 3 is a transverse vertical section through the same on the line x x , Fig. 2. Fig. 4 is a longitudinal vertical section on the line y y of Fig. 2. Fig. 5 is a perspective view of one of the coupling-wires detached.

My invention consists in an octave-coupler of peculiar construction, by means of which an increased leverage is secured, giving a lighter touch to the instrument, while at the same time the liability to get out of order is diminished. My invention also consists in a device to be used in connection with the coupler for the purpose of throwing it in and out of action, when desired.

To enable others skilled in the art to understand and use my invention, I will proceed to describe the manner in which I have carried it out.

In the said drawings, A represents the bed or frame through which pass the rods a b , by which the valves which admit air to the reeds are opened when the keys are depressed, in a well-known manner. B is the key-frame, to the rear end of which are pivoted the key-levers C D E G, the notes corresponding to the levers E G being an octave higher than those of the levers C D, the intermediate levers being omitted. H H are the couplers, which are formed of stiff wire and arranged side by side, as seen in Figs. 1 and 2. Each of these wires is bent into the shape seen in Fig. 5, so as to form two branches, 6 7, and a vertical portion or offset, 8, the end of the branch 6 being pivoted at c to a stationary bar or support, I, while the end of the branch 7 is pivoted at d to a movable bar, K, hinged at its lower rear

edge to the bed A, for a purpose to be hereafter described, the bars I K extending along the entire length of the key-board. The form of the wire H is such as to extend out from each end between the valve-rods and across the space between the keys to be connected, the branch 6 resting on a button or collar, e , on the valve-rod b , while the branch 7 extends beneath a pin or projection, f , on the under side of the key-lever which operates the valve-rod a , and thus when the coupling-wire is depressed by the contact of the pin f of the lever C with its branch 7, its opposite branch 6 is caused to depress the valve-rod of the key E of the next octave, causing both notes to be sounded simultaneously, as desired, by the pressure of a single key. The form of the wire also admits of its passage between the valve-rods without coming into contact therewith, while the offset or vertical portion 8 causes the plane of the branch 6 to lie below that of the branch 7, and thus allows each wire to be depressed without interfering with those adjacent thereto. L is a horizontal bar which extends longitudinally across the bed A over the couplers, and serves to prevent the latter from rebounding and striking the key-levers.

Two coupling-wires H only are shown in the drawings to illustrate the invention, but a sufficient number of these wires are to be employed to couple the keys throughout the key-board. M is a slide which is moved against the resistance of a spiral spring, g , by an arm, h , projecting up from a horizontal rock-shaft, N, at the opposite end of which is an arm or lever, i , which is intended to be connected with an ordinary draw-stop. The front of the movable bar K is connected with the slide M by two pivoted links, k k , which are inclined at an angle, so that when the slide is advanced against the resistance of the spring g , the hinged bar K will be raised, thus elevating one end of each coupling-wire, and bringing it into a position to be struck and operated by the pin f of the key-lever above when the latter is depressed, and the couplers are thus thrown into action, as desired. When the slide is returned to its normal position by the spring g the bar K is brought down into the position seen in Fig. 3, which lowers the

branches 7 of the coupling-wires so that they will be out of reach of the pins *f* of the key-levers.

It will be seen that the pressure of the pin *f* of the key-lever is applied to the coupling-wire H at a considerable distance from its fulcrum or end where it is pivoted to the bar K, and by this construction and arrangement of parts a greater leverage is secured than heretofore, which gives a much lighter touch to the instrument, while there is very liability of the mechanism getting out of order, on account of its simplicity and strength.

All of the friction-surfaces and points of contact between the movable parts are covered with felt or other suitable material to deaden and prevent sound, as usual in musical instruments.

What I claim as my invention, and desire to secure by Letters Patent, is—

1. The coupling-wire H, with its branches 6 7 bent so as to extend out from each end between the valve-rods, and provided at its outer or middle portion with a vertical offset, 8, all constructed and arranged substantially as and for the purpose described.

2. In combination with the coupling-wire H, formed as described, and pivoted at one end to a stationary support, I, the movable bar K, having attached thereto the opposite end of the coupling-wire, and arranged to operate substantially in the manner and for the purpose set forth.

Witness my hand this 31st day of July, A. D. 1875.

SAMUEL J. CROCKETT.

In presence of—

P. E. TESCHEMACHER,
W. J. CAMBRIDGE.