

N. KEELY.  
Paper-Tube Machine.

No. 169,107.

Patented Oct. 26, 1875.

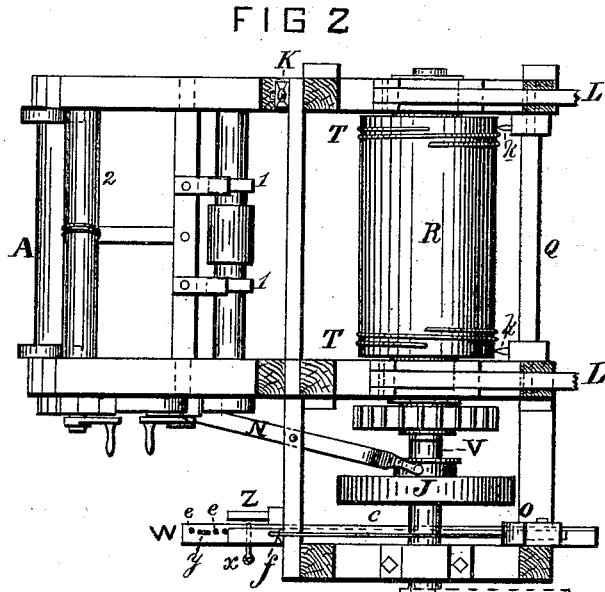
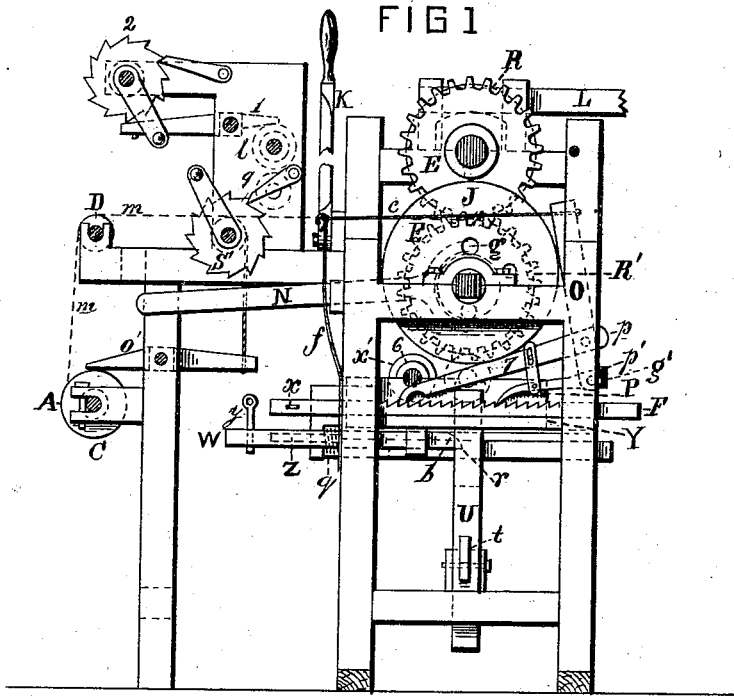

WITNESSES.  
*Smith*  
*Henry C. Mox*

INVENTOR.  
*Nice Keely*  
 by his attorney  
*Joshua Ducey,*

# N. KEELY. Paper-Tube Machine.

No. 169,107.

Patented Oct. 26, 1875.

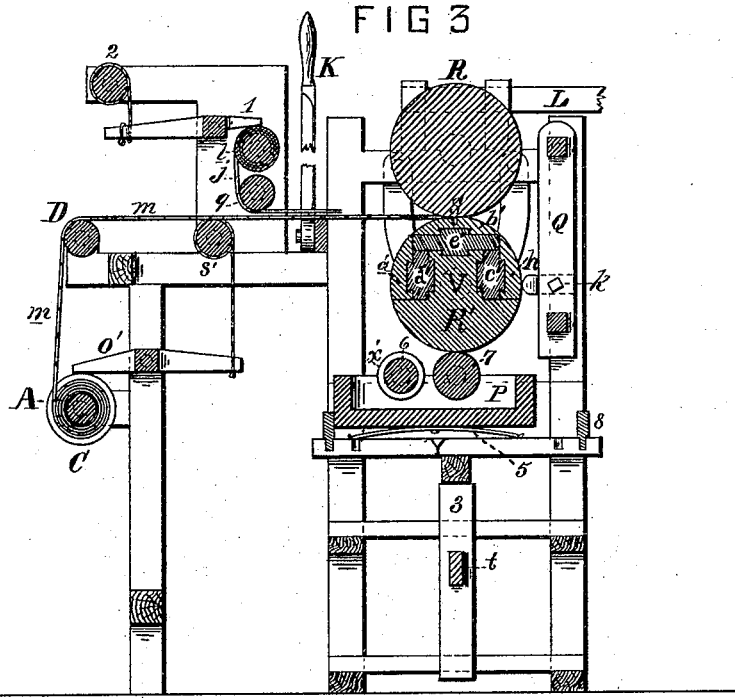

FIG 4

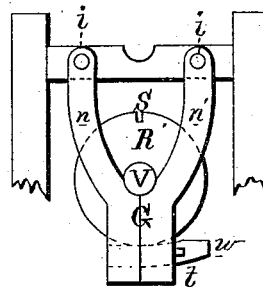
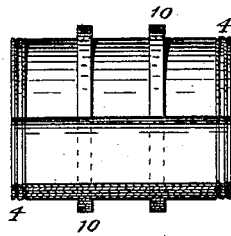

FIG 5



WITNESSES.

*Amvithell*  
*Henry C. Moss*

INVENTOR.

*Nice Keely*  
by his Attorney  
*Joshua Dusey.*

# UNITED STATES PATENT OFFICE.

NICE KEELY, OF LEVERINGTON, PENNSYLVANIA.

## IMPROVEMENT IN PAPER-TUBE MACHINES.

Specification forming part of Letters Patent No. 169,107, dated October 26, 1875; application filed October 1, 1874.

*To all whom it may concern:*

Be it known that I, NICE KEELY, of Leverington, in the county of Philadelphia, State of Pennsylvania, have invented an Improved Paper-Tube Machine, of which the following is a specification:

The object of my invention is, generally, to provide a machine for the fabrication of uniform hollow cylindrical shells made up of several agglutinated convolute layers of paper, and, particularly, for the formation of the shell or body of a certain improved paper cask or other receptacle of which I am the inventor, and for which Letters Patent are pending.

Figure 1 of the annexed drawings represents a side elevation of my machine; Fig. 2, a plan of the same; Fig. 3, a medial longitudinal section; Fig. 4, a detached view of a bisected hanger employed to support one end of the journal of the lower or former roll, hereinafter described. Fig. 5 represents a shell or body, a part in longitudinal section, of one of my improved casks as formed by the machine.

Like letters and figures, where they occur in the several drawings, refer to corresponding parts.

My invention will be best understood by detailing in full the *modus operandi* of its constituent mechanism from the coil of paper A on roller C to the final removal of the completed shell from the cylindrical former R'. The continuous broad strip of paper *m* passes over the idle-roller D, and then horizontally beneath the cut-off knife K onto the roll R', where its end is inserted in a slit, *s*, traversing the length of the roll. R and R' are superimposed cylinders whose diameters are identical with the inside diameter of the shell which it is proposed to form. They are geared together by the spur-wheels E E. The upper roll, R, is a calender-roll, plain and smooth, except in that it bears on and around its periphery, near either extremity, a screw-thread, T, Fig. 1, in high relief, corresponding to like *in-taglio* threads (not shown in drawings) placed in juxtaposition thereto in the surface of the nether roll R'. These threads, as the winding of the layers of paper around R' proceeds, impress their fac-similes in the paper shell 4, as will appear by reference to Fig. 5. The free end of *m* having been introduced into slit *s*, as

mentioned, R and R' are then rotated forward by means of handle H (for which a pulley is substituted when the apparatus is to be operated by power) until the slit, and consequently the end of strip *m*, is in a vertical line, passing through the centers of both the upper and lower rolls. The drawings represent the same in such position. *m* is kept at proper tension by means of a brake or brakes, O', pressing on the flanges of roller C, and which are connected with and operated by a ratchet-winch, S', Figs. 1 and 3. The required degree of pressure on the paper (and experience proves that considerable pressure is advantageous) as it winds on R' is secured by weighting levers L, which bear, near their fulcrums, on the upper half of the journal-boxes of R. The shell, Fig. 5, being constructed of a certain number of conglutinated layers of strip *m*, each layer corresponding to a revolution of the rolls, it is necessary at a particular point in their revolutions to drop down the paste-box P, which carries the paste-applying rollers 6 and 7, whereby the application of the paste shall temporarily cease. This movement occurs when R R' have made half a turn less than is sufficient to complete the final layer of paper of each shell.

I shall now proceed to a description of the devices by the co-operation of which this end at the proper periods is effected. A shifting eccentric-cam, J, located on shaft V of roll R', and slotted in order to slide over a spline on the same, is thrown in and out of position by means of a lever, N, pivoted on a cross-piece in the frame of the machine.

In Fig. 2 the eccentric is represented out of position. When in position its face impinges, as it revolves, against the long arm of a lever, O, which oscillates about a fulcrum-pin fixed in the frame-work. O is held against the stop *g'*, or, when cam J rotates, against the face of the latter by means of a spring, *f*, with which O is connected by a cord, *c*, or otherwise. The oscillation of O, caused by the rotation of the cam, transmits motion to two connected pawls, *p p'*, hinged to lever O, which advances a ratcheted rack, F. The office of *p'* is to move the rack. *p* is simply ancillary, keeping F in place while the former retreats into the next succeeding tooth.

F is provided at or near one end with a hori-

zontal pin,  $x$ , which, as the former is pushed on, comes in contact with a vertical pin or stud,  $y$ , inserted in one of a series of holes,  $e e$ , Fig. 2, in a sliding bar,  $W$ . The distance apart of  $e e$  corresponds with that of the teeth of rack  $F$ , consequently when  $y$  is placed, for example, in the fifth hole, counting from toward the end of  $F$ , pin  $x$  will strike against  $y$  on the fifth revolution of shaft  $V$ —that is to say, of rolls  $R R'$ . Now, the piece  $W$  has attached firmly thereto a second bar or rod,  $Z$ , ending in a bevel catch,  $b$ , which latches in a slot,  $r$ , shown in dotted lines, Fig. 1, in an upright,  $U$ , toward which  $Z$  is forced by a helical spring,  $g$ .  $U$  is located directly beneath  $J$  when the latter is in position,  $J$  just escaping the end of the upright when held by catch  $b$ . It is also connected by a rock-bar,  $t$ , with a second parallel upright,  $3$ , which supports platform  $Y$ , upon which paste-box  $P$  is placed. When pin  $x$  is caused to impinge against stud  $y$ , catch  $b$  retreats from slot  $r$ , and, as the cam moves on around to complete its final revolution,  $P$  drops a short distance by its own gravity, so that the paste supply rollers 6 or 7 (which ever may be in actual use at the moment) will clear the face of  $R'$ , or rather of the shell of paper encompassing the same. Strip  $m$  is cut off by the hand-knife  $K$  when  $R R'$  have made a half revolution less than the requisite number for completing the shell. The distance of the cut-off to the line of contiguity of the superimposed rolls is equal to one-half the diameter of  $R'$ . So soon as  $m$  is severed  $R$  and  $R'$  are turned forward, whereby the pasting on of the remainder of the strip is accomplished, the paste, it is clear, having already been applied to the approaching semi-periphery of the shell when the paste-box dropped. The tubular shell, Fig. 5, is now ready for the attachment of one or more, as desired, strengthening-bands, 10, pasted in successive layers by repetition of the described operation of forming the main body. The narrow strips of paper  $j$ , from which these reinforcing bands are made, are supplied from a roller,  $l$ , around which they are coiled. They pass under the idle-roller 9, thence under knife  $K$  to rolls  $R R'$ .

Tension is secured by the combination of the brake 1 and ratchet-winch 2.

When more than one of such strips are used they may be so fixed on sleeves passing over  $l$  or otherwise as to allow their independent motion.

It has been seen that paste-box  $P$  is placed on a platform,  $Y$ , which connects by a rock-lever with vertical piece  $U$ . To the bottom of  $P$  are secured curved springs 5, Fig. 3, which permit rollers 6 7 to yield as the number of superimposed layers of paper increases. One of said rollers, 7, is used to apply the paste, with which  $P$  is provided, along the entire width of  $m$ .

The office of roller 6 is to apply the paste for the narrow strips  $j$  only. This necessitates the employment on this roller of flanges

or collars  $x'$ , the width of strips  $j$  projecting above the body of the roller, and located in line with the paper strips.

The broad surface-roller 7 is represented in the drawings as in use.

When the plain shell is finished  $P$  is drawn forward against the front stop-pin 8, which is so placed as to adjust 6 directly under the center of  $R'$ , in position for applying paste to bands  $j$ . Cam  $J$  having been now first thrown, as represented in Fig. 2,—that is, out of position—handle  $H$  is turned forward, which revolves  $R R'$ , while, at the same time, knives  $k$ , attached outside the screw-threads on the rolls, to swinging frame  $Q$ , are pressed by hand against the paper cylinder, neatly trimming off its ends. The shell is now ready to be removed from  $R'$ , which it tightly embraces. In order to do this the layers of paper being compressed with considerable force into the intaglio screw-thread on  $R'$ , it becomes necessary to reduce the diameter of the latter.

A reference to the sectional view, Fig. 3, will discover that  $R'$  is provided with three movable sections,  $a' b' h$ , firmly held to the main body of the roll by as many dovetail keys or wedges  $c' d' e'$ , constructed (as also are  $R$  and  $R'$ ) of iron, and nicely fitted in. These keys are easily knocked out by means of a simple rod or punch passed through openings  $g$  (only one of which is visible in the Fig. 1) in cam  $J$ , and continued through the lower spur-wheel  $E$ . It is evident that when the keys are thus driven out a sufficient portion of roll  $R'$  will collapse, to permit the ready removal of the shell, two halves,  $n n'$ , of the hanger, Fig. 4, having been first thrown apart. Hanger  $G$  is composed of two similar parts,  $n n'$ , pivoted respectively, on pins  $i i$ , fixed in a cross-piece of the frame-work  $n$  and  $n'$  are held together by means of a pin,  $t$ , passing through the curved projection  $w$ , which works in a similarly-curved slot in  $n$ .

Instead of the particular arrangement of the wedges  $c' d' e'$ , as described, the sections  $a' b' h$  may be bound together by a single central tapering key, dovetailing into the several sections of the roll.

After removal of the shell from  $R'$  rack  $F$  is pushed back, as at first, either by the hand or by means of a suitably-arranged spring, eccentric  $J$  again thrown into position, and the operation of forming the succeeding shell is proceeded with as before.

The upper or calender roll  $R$  may be made hollow, so as to be heated by steam or otherwise; and, also, the paste-conveying rollers 6 7 may be covered with felt or other yielding material.

It is obvious that several paper cylinders may be produced at each operation instead of a single one, as herein shown, by merely elongating rollers  $R R'$ , and providing them with several series of screw-threads located at suitable intervals apart.

I claim—

1. The combination of the co-acting rolls R R', the latter constructed in sections and encircled with series of intaglio threads, as and for the purposes described.

2. In combination with paper-supply rollers C and I, and rolls R R', the cut-off knife K, and adjustable trimmers k.

3. The combination of cam J, lever O, pawls p p', ratchet-rack F, and sliding bar W, provided with piece Z, terminating in catch b, playing into slot r in upright U, all combining to operate box P, substantially as described.

4. Box P, provided with paste-distributing rollers 6 7, and springs 5.

5. The double dovetail keys e' d' e', in combination with the respective sections of roll R', substantially as represented, and for the purposes described.

6. Bisected hanger G, composed of separable parts n n', lug w, and pin t, substantially as represented and described.

NICE KEELY.

Witnesses:

R. N. WETHERILL,  
H. W. TAYLER.