

E. KUESSNER & T. BREUER.

Oil-Can.

No. 169,109.

Patented Oct. 26, 1875.

Fig 1

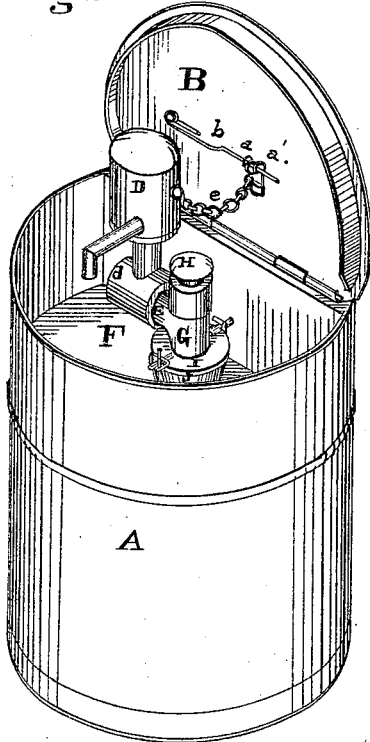

Y

Fig 2

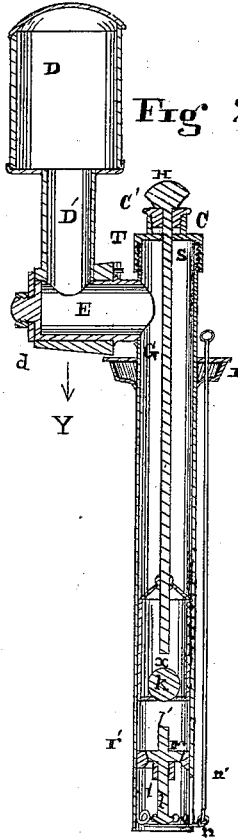

Fig 3

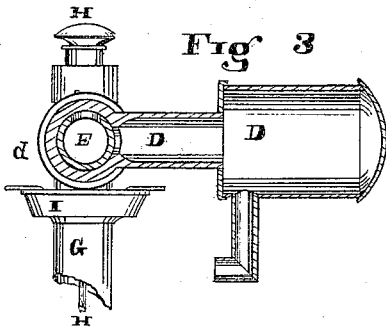
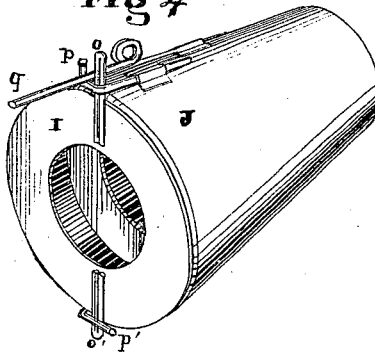

Fig 4



Attest
James Moore
M. M. Oliver

Inventors
Edward Kuessner
Theodore Breuer
by Geo. Murray Atty

UNITED STATES PATENT OFFICE.

EDWARD KUESSNER AND THEODORE BREUER, OF CINCINNATI, OHIO.

IMPROVEMENT IN OIL-CANS.

Specification forming part of Letters Patent No. 169,109, dated October 26, 1875; application filed May 10, 1875.

To all whom it may concern :

Be it known that we, EDWARD KUESSNER and THEODORE BREUER, of Cincinnati, in the county of Hamilton and State of Ohio, have invented a new and Improved Oil-Can, of which the following is a specification :

Our invention relates to that class of oil cans or tanks used by retail dealers for holding kerosene and other oils.

The invention consists, first, in the construction of a pump with an adjustable closed top attached to the top or cover of the can, so as to be raised to the proper position for use when the cover is raised, and turned down by the cover when the can is closed; second, in a peculiar arrangement of valve and valve-lifter, by which the oil is always kept in the pump ready for use when in the can, and by which the pump can be emptied when it is necessary to remove it from the can to pump oil from the barrel into the can, or for any other purpose; third, in locking devices for securing the pump in the can.

The object of the invention is to provide a means by which the common flat cover may be used instead of the inconvenient and expensive hood now necessary in this class of oil-cans, and to avoid the uncleanness consequent upon the overflowing or leakage of the pump. The first object is accomplished by the adjustable pump, which, when turned down, occupies no more space in the can than is necessary to hold the measures, and when the can is open stands high enough to permit the largest measure to stand under the spout. It also permits the use of the flat cover, which, in addition to its cheapness, permits the can to be opened for use when pushed up against the wall, thus economizing space in the store.

In the drawings, Figure 1 is a perspective view of the can, the cover being raised, and the pump attached, and elevated ready for use. Fig. 2 is a central vertical section of the pump removed and in the position it occupies, when ready for use. Fig. 3 is a view, partially in section, of the pump, in a plane at right angles to the view shown in Fig. 2; taken through the line *yy* it shows the position of the pump when the can is closed. Fig. 4 is an enlarged perspective view of the neck or

socket, with the plug and locking devices for securing the pump in the can.

A is the body of the can, fitted with the shelf or measure-rest F, to which the neck or socket J is attached for supporting and retaining the pump in position. B is the cover to which the hooks *a a* and spring-latch *b* are secured, the purpose of the hooks and latch being to attach and retain one end of the chain *e*, the other end of the chain being secured to the pump-head D. G is the pump-cylinder, fitted with a hollow plunger, *x*, (which contains the ball *k*,) check-valve *r*, and valve-seat *r'*. To the valve-seat *r'* is centrally suspended the stem-guide *t*. From the upper and lower faces of the valve *r* the stems *l'* and *l* project, the enlarged end of the stem *l* resting upon the horizontal part of a wire valve-lifter, *n*, which is coiled as a spring, and attached at one side of the cylinder G, and passing centrally across the cylinder and out through a vertical slot in its opposite side connects with a link, *n'*, which passes up along the side of the cylinder through the plug J, and terminates in a handle. Projecting from the cylinder G is a cylinder, E, perforated upon its upper side, and around which another cylinder, *d*, correspondingly perforated, fits closely thereto with the cylinder D', the lower opening of which registers with the opening in the cylinder E when the head D of the pump is raised, and cuts off when the head is turned down, as seen in Fig. 3, forming a faucet connection or joint. S is a ring threaded externally, the inside diameter being the same as cylinder G, to the top of which it is secured by soldering or otherwise. T is the cap, which screws on ring S. C is the stuffing-box attached to cap T; and C' is the screw-plug, fitting into it. This latter is perforated centrally, as is also the cap T, to admit the plunger-rod H. This plunger-rod H extends some distance into the hollow plunger *x*, so as to allow the ball *k* but a limited play. I is a plug, perforated to receive the pump-cylinder, to which it is secured permanently. It has a flange projecting around its top edge to prevent its too deep insertion in the socket J, and projecting upon its opposite sides are lugs *o o'*, which, in connection with hooks *p p'* and

spring *q*, which are secured to the side of socket *J*, lock the pump in its place. The socket *J* is permanently secured in the shelf *F*. When it is necessary to remove the pump the spring-latch *b* is slipped from under the hooks *a a*, and the chain *e* slipped off. The spring *q* is then turned over the lug *o*, when, by turning the pump and plug *I*, the lugs are released from the hooks *p p'*, when the pump may be withdrawn, and by drawing up the link *n'* the check-valve *r* is lifted by the valve-lifter *n*, the stem *l'* at the same time lifting the ball-valve *k*, thus allowing all the oil in cylinder *G* to run out.

One of the difficulties attending all pumps heretofore used for this purpose was that the oil would fill up at the top and run down the handle, or overflow, and especially when pumping from the barrel into the can, as the pump could not then be in a vertical position. This

defect is overcome in our pump, as no oil can escape except at the spout.

I claim—

1. In the oil-can *A* the adjustable pump-head *D, D'*, and *d*, fitted to turn on cylinder *E*, substantially as specified.

2. In a pump for oil-cans, the combination, substantially as described, of check-valve *r*, having stems *l* and *l'*, valve-lifter *n*, and link *n'*.

3. The combination of plug *I*, secured to cylinder *G*, and having lugs *o o'*, and socket *J*, secured to shelf *F*, and having hooks *p p'*, and springs *q*, substantially as and for the purpose set forth.

EDWARD KUESSNER.
THEODORE BREUER.

Witnesses:

JAMES MOORE,
GEO. J. MURRAY.