

W. BECKERT.
Doubletree-Clip.

No. 169,135.

Patented Oct. 26, 1875.

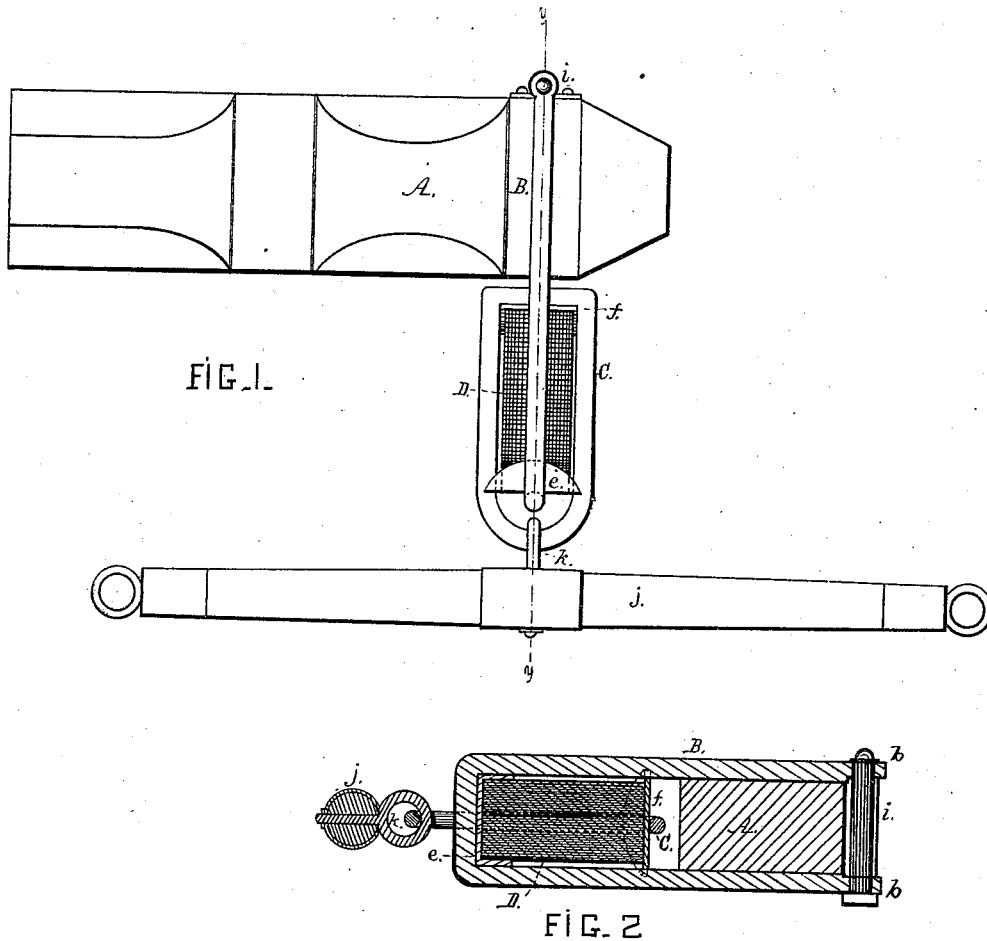

WITNESSES.
B. L. Johnston
J. S. Thompson.

INVENTOR.
Wm Beckert
By A C Johnston
his Attorney.

UNITED STATES PATENT OFFICE.

WILLIAM BECKERT, OF ALLEGHENY, PENNSYLVANIA.

IMPROVEMENT IN DOUBLE-TREE CLIPS.

Specification forming part of Letters Patent No. 169,135, dated October 26, 1875; application filed August 6, 1875.

To all whom it may concern:

Be it known that I, WILLIAM BECKERT, of Allegheny, in the county of Allegheny and State of Pennsylvania, have invented a new and useful Improvement in Double-Tree Clips; and I do hereby declare that the following is a full and exact description thereof, reference being had to the accompanying drawings, and to the letters of reference marked thereon.

My invention relates to an improvement in double-tree clips, in which a spring is employed, whereby any sudden jar which the vehicle may be submitted to will be transmitted to said spring; and it consists in a swinging clip, in combination with a link, and guides arranged in combination with a spring, as hereinafter set forth and claimed.

To enable others skilled in the art to make and use my invention, I will describe its construction and operation.

In the accompanying drawings, Figure 1 is a top view or plan of my improvement in double-tree clips for vehicles. Fig. 2 is a vertical and transverse section of the same at line *y* of Fig. 1.

A represents the double-tree, which is of ordinary construction, and to which is pivoted at *i* the ends *b b* of the clip B, within which is placed the link C, within which, between two abutments, *e* and *f*, is arranged an elastic spring, D. The abutment *e* is secured in the

front end of the clip B, and in each of its sides is a recess, in which the link C moves, so that the abutment acts as a guide for the front part of the link. The abutment *f* is secured within the link C at its back end, and its upper and lower edge is furnished with a recess for the upper and lower arms of the clip B, so that the abutment *f* serves as a guide for the back end of the link C. The single-tree *j* is attached to the link C at K.

By this arrangement of parts a perfectly-solid rubber spring may be used, and it will be protected by the clip and link.

The force to move the vehicle is brought on the spring D by the draft of the team; and, in case the vehicle comes in contact with any obstruction, the jar which is transmitted to the horse will be expended on the spring.

What I claim is—

The swinging clip B, passing at one end around the spring D, and having its ends *b b* pivoted to the double-tree at *i*, as shown, in combination with the abutments *e f* and link C, also passing around said spring, all constructed and arranged substantially as shown, and for the purpose set forth.

In testimony whereof I hereunto set my hand this 20th day of July, 1875.

WILLIAM BECKERT.

Witnesses:

A. C. JOHNSTON,
B. L. JOHNSTON.