

T. H. CLARK,
Turbine-Wheel.

No. 169,148.

Patented Oct. 26, 1875.

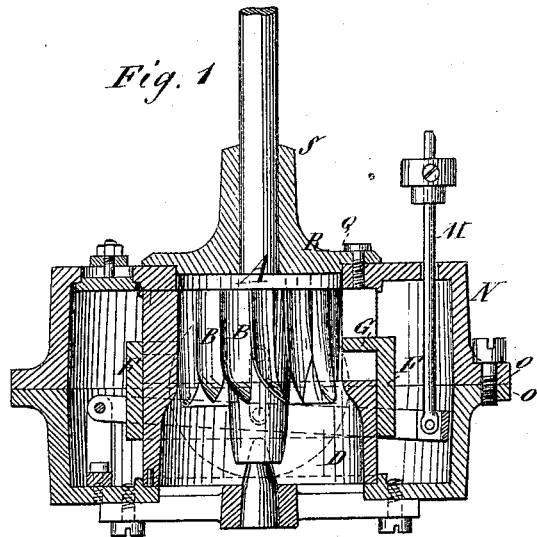

Fig. 1

Fig. 2

Fig. 3

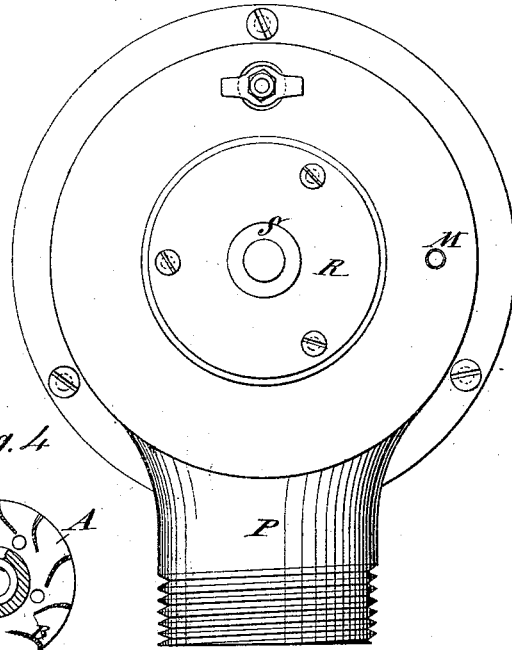
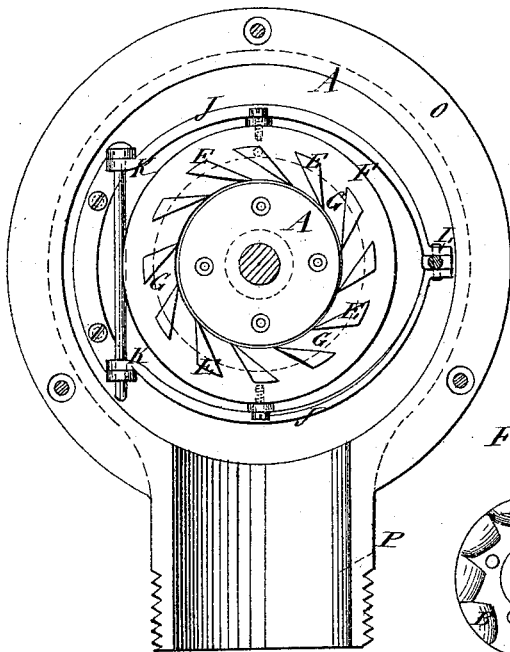

Fig. 4

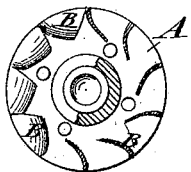
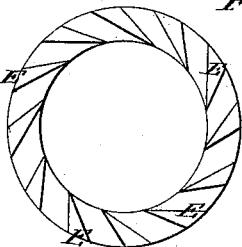
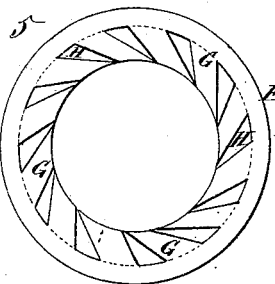

Fig. 5

Fig. 6

WITNESSES:

C. Novaux
A. J. Terry



INVENTOR:
T. H. Clark
BY
Wm. H. [Signature]
ATTORNEYS.

UNITED STATES PATENT OFFICE

THOMAS H. CLARK, OF HELENA, MONTANA TERRITORY.

IMPROVEMENT IN TURBINE-WHEELS.

Specification forming part of Letters Patent No. **169,148**, dated October 26, 1875; application filed May 22, 1875.

To all whom it may concern:

Be it known that I, THOMAS H. CLARK, of Helena, in the county of Lewis and Clark and Territory of Montana, have invented a new and Improved Turbine-Wheel, of which the following is a specification:

This invention relates to that class of wheels which receive the water horizontally upon the upper part of the buckets, through stationary chutes surrounding the buckets, and discharges it vertically and rearwardly; and it consists in the apparatus hereinafter described for operating the gate.

Figure 1 is a sectional elevation of my improved wheel, taken through the center. Fig. 2 is a horizontal section. Fig. 3 is a plan view. Fig. 4 is a view of the wheel inverted and partly sectioned. Fig. 5 is a plan view of the gate, and Fig. 6 is a top view of the chutes.

Similar letters of reference indicate corresponding parts.

A is a horizontal top plate to the wheel, and B the buckets, which are concave in cross-section, and for the most part are projected vertically from the lower side of the plate, but curve backward for about one-fourth of their length at the lower part, and they are set with the outer edges radial to the wheel, while the inner portion curves around to rearward, about one-fourth of a circle. D is the draft-tube below the wheel, which is constructed with gradually increasing size from the buckets to the bottom of the wheel-case, to give ample room for the escape of the water from the wheel to better advantage than it can when the tube is one size throughout. E represents the chutes, which are formed in a thickened upper extension of the draft-tube

by slots formed in it from the top, the tube being just large enough to fit close around the wheel, so that no water can pass between the chutes and the wheel. The gate F is a sleeve, fitting snugly around the chutes with a flange, G, on the upper end, projecting inward to the wheel, and having slots H, corresponding in shape to the chutes, and allowing it to drop down between the chutes for opening the gate and forming the bottom to the chutes when the gate is partly open, confining the water just the same, and causing it to act with the same ratio of effect for part as for whole gate. For opening and closing the gate it is pivoted on opposite sides to the ring-lever J, having its fulcrum at K, and connected at L to the rod M, passing up through the case N, to be connected to the proper contrivance for working it. The case N is cast in two half parts, divided horizontally in the middle, and having a flange, O, for bolting together; also, a horizontal tube, P, for the connection of the pen-stock; also, the draft-tube D; and in the upper part is a large central opening, Q, for introducing the wheel, with a plate, R, for closing it, in which is the upper bearing S for the wheel shaft.

Having thus described my invention, I claim as new and desire to secure by Letters Patent—

In a water-wheel, the combination with a vertically-adjustable gate, F G, the pivoted ring-lever J, and rod M, substantially as shown and described.

THOMAS H. CLARK.

Witnesses:

CHARLES RUMLEY,
GEORGE P. REEVES.