

D. E. DAVIES.
Dumping-Wagon.

No. 169,153.

Patented Oct. 26, 1875.

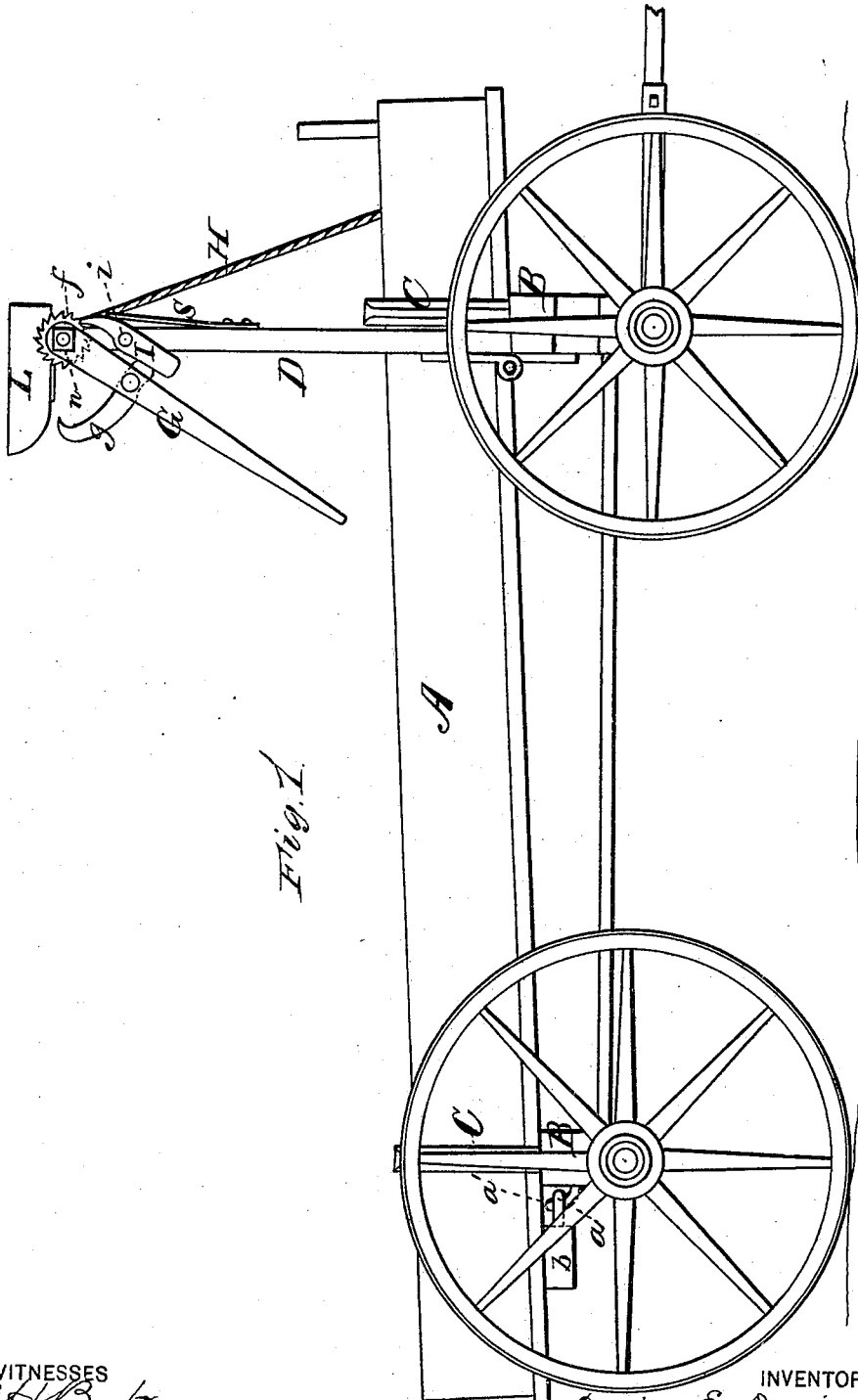

Fig. 1

WITNESSES
E. H. Bates
Francis J. Classi

INVENTOR
David E. Davies
Chipman Josiah Co.
ATTORNEYS

D. E. DAVIES.
Dumping-Wagon.

No. 169,153.

Patented Oct. 26, 1875.

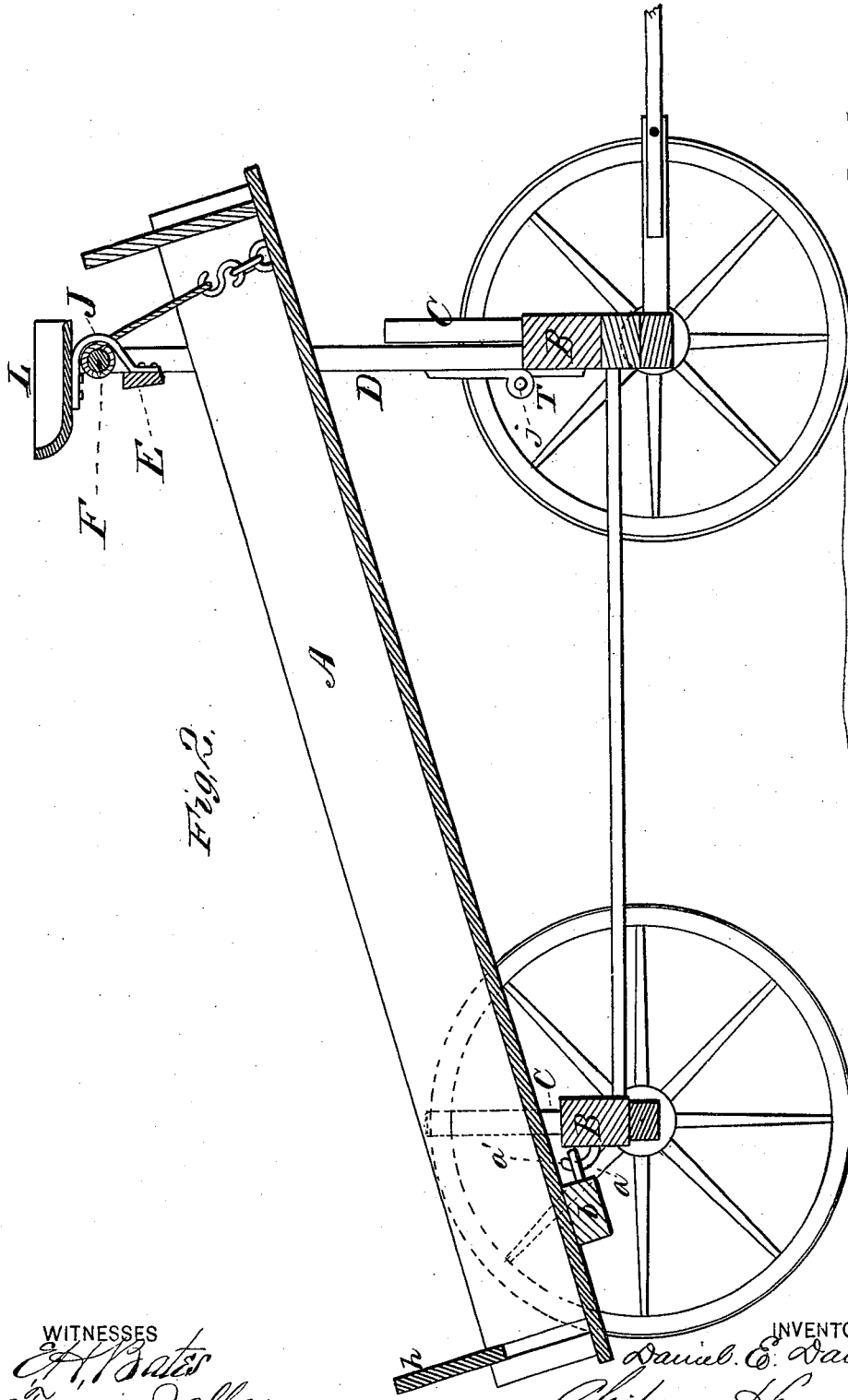

Fig. 2.

WITNESSES
A. Bates
Francis J. Chase

INVENTOR
Daniel E. Davies
Chipman & Howard Co.
ATTORNEYS

UNITED STATES PATENT OFFICE.

DANIEL E. DAVIES, OF DUNDAFF, PENNSYLVANIA.

IMPROVEMENT IN DUMPING-WAGONS.

Specification forming part of Letters Patent No. **169,153**, dated October 26, 1875; application filed September 11, 1875.

To all whom it may concern:

Be it known that I, DANIEL E. DAVIES, of Dundaff, in the county of Susquehanna and State of Pennsylvania, have invented a new and valuable Improvement in Dumping-Wagons; and I do hereby declare that the following is a full, clear, and exact description of the construction and operation of the same, reference being had to the annexed drawings, making a part of this specification, and to the letters and figures of reference marked thereon.

Figure 1 of the drawings is a representation of a side elevation of my wagon, and Fig. 2 is a longitudinal vertical sectional view of the same.

This invention has relation to improvements in dumping-wagons; and the nature of the invention consists in combining, with a vertically-vibrating wagon body or box, a crane or derrick, a windlass, an operating-lever, and cords, as will be hereinafter more fully explained and claimed.

In the annexed drawings, the letter A designates an ordinary wagon-box of the description commonly used with four-wheeled running-gear, which is supported by means of bolsters B, and is held against lateral displacement by standards C. Box A is hinged, so as to vibrate vertically, to the rear bolster B by means of staples or eyebolts *a*, which are driven into a cleat, *b*, on the bottom of the box, and of upturned hooks *a'* on the said bolster, which engage with the said eyebolts or staples, as shown in Fig. 1. By this means the box is capable of being raised in front to any desired height, for the purpose of dumping a load bodily from its rear, but yet may be raised out of the standards with great ease, the ends of the hooks being barely within the eye of the bolts. D represents standards or uprights of suitable strength, arranged at each side of the box. The upper ends of these uprights are connected together by a strong brace, E, and their lower ends are detachably secured or hinged to the front bolster. Their upper ends also afford bearings for a horizontally-arranged winding-drum, F, having upon one end a ratchet-wheel, *f*, and a vertically-vibrating lever, G, which are held in place by means of a nut, *n*. Lever G is provided with a metallic hook, *g*, which is adapted to

engage with the ratchet-wheel *f* when the power end of the said lever is thrust rearwardly and downwardly, thereby causing the winding-drum to rotate and wind up elevating ropes or chains H, which are secured to the said windlass and wagon-box, and raising the front of the latter into the position shown in Fig. 2. The tail-board *h* being up, the contents of the wagon will, of course, glide out of it upon the ground.

In order to prevent the winding-drum from rotating backward, as well as to hold the wagon-box in a raised position, I employ a strong metallic pawl, I, pivoted at *i* to upright D, which pawl engages with ratchet-wheel *f*, being held yieldingly in contact therewith by means of a spring, S.

In order that the driver may not be obliged to dismount, thus losing the mastery of the team, for the purpose of dumping the load, the seat L is mounted by means of a flat steel spring, J, upon the connecting-bar E of standards D, within easy reach of the said driver. By this means he may, without leaving his seat, operate lever G, raise the front end of the wagon-box, and dump his load. He may also, from the same position, lower the box to a horizontal position by disengaging pawl I and hook *g* from ratchet-wheel *f*. This being done, the box will gravitate to its proper position on the bolsters without further effort.

Spring J, as shown in Fig. 2, is of curved form, one end being secured to the seat and the other to cross-bar E, the curvature being given for the purpose of avoiding winding-drum F; but under some circumstances, as where the body is unusually heavy, its friction upon the drum, caused by the driver's weight, may be utilized as a brake, for the purpose of preventing the body from falling into position with undue violence.

When the elevating device above described is not required for use, it may be detached bodily from the bolster by withdrawing the pins *j*, connecting the two straps or sections of the hinge T.

What I claim as new, and desire to secure by Letters Patent, is—

1. In combination with a derrick or bridge crane, a windlass, and a vertically-vibrating hinged wagon-box, the ratchet-wheel *f*, vibrat-

ing lever G, having pivoted hook *g*, pawl I, and spring S, substantially as specified.

2. The combination of the bridge-crane D E, the mechanism for raising a wagon body or box, and the driver's seat L, substantially as specified.

3. The combination of a brake-spring, J, with a driver's seat, L, and the winding-drum F of bridge-crane D E, substantially as specified.

4. In combination with the running-gear of

a wagon, the removable bridge-crane D E, supporting the hoisting mechanism of a dumping-wagon, substantially as specified.

In testimony that I claim the above I have hereunto subscribed my name in the presence of two witnesses.

DANIEL E. DAVIES.

Witnesses:

JASPER WITTER,

J. B. SLOCUM.