

W. I. GRANT.
Horse-Power.

No. 169,164.

Patented Oct. 26, 1875.

Fig. 1.

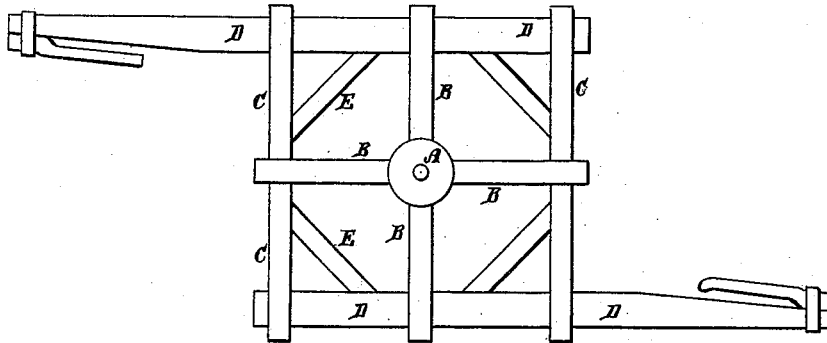
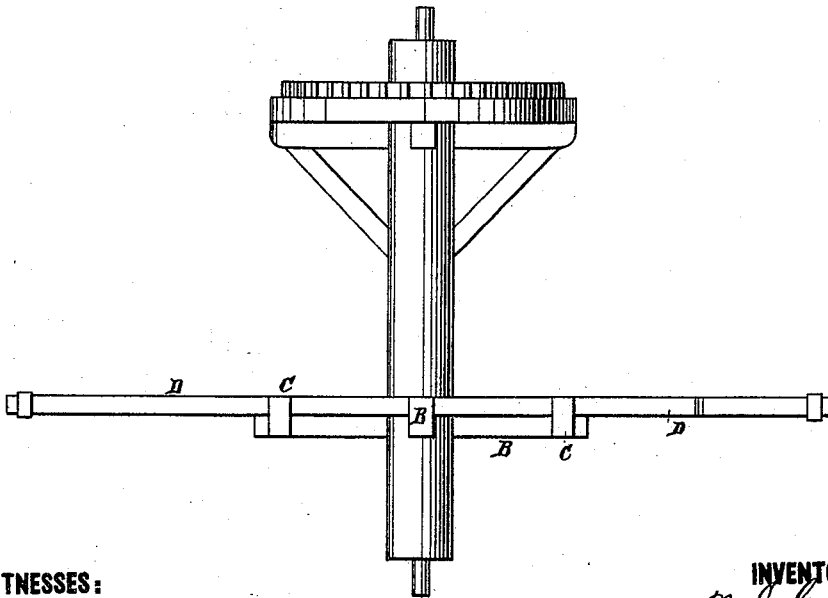

Fig. 2.



WITNESSES:

A. Bennekenhoff.
Chelquick

INVENTOR:

W. I. Grant

BY

Munroe

ATTORNEYS.

UNITED STATES PATENT OFFICE.

WILLIAM I. GRANT, OF MAGNOLIA, ARKANSAS.

IMPROVEMENT IN HORSE-POWERS.

Specification forming part of Letters Patent No. **169,164**, dated October 26, 1875; application filed April 18, 1874.

To all whom it may concern:

Be it known that I, WILLIAM I. GRANT, of Magnolia, in the county of Columbia and State of Arkansas, have invented a new and Improved Horse-Power, of which the following is a specification:

My invention consists of a method for attaching the sweeps to the shaft or king-post of the ground-wheel by a frame attached to arms radiating from the shaft, so as to support the sweeps on the opposite sides of the shaft at considerable distance therefrom, whereby an increased leverage is obtained with a sweep of a given length, and the connection with the king-post is made very firm and substantial.

Figure 1 is a plan view of my improved horse-power. Fig. 2 is a side elevation.

Similar letters of reference indicate corresponding parts.

A is the king-post or shaft; B, radiating arms; C, bars connecting the sweeps D, also connecting them with some of the said arms;

and E, braces connecting the sweeps and bars C, all so as to constitute a strong frame for connecting the sweeps to the king-posts, and supporting the sweeps in advance of the king-post the length of the radial arms, by which leverage is gained in proportion to the length of the sweeps, and the connection of the sweeps to the king-post is made very substantial.

I do not claim, broadly, attaching sweeps to the radial arms of a king-post; but,

Having thus described my invention, I claim as new and desire to secure by Letters Patent—

The combination of the radial arms B, arranged at right angles, the sweeps D D, their parallel connecting-bars C, and the diagonal braces E, with the king-post, all arranged as shown and described.

WILLIAM I. GRANT.

Witnesses:

J. H. ATKINSON,
J. M. JACKS.