

J. B. SMITH.
Car-Coupling.

No. 169,201.

Patented Oct. 26, 1875.

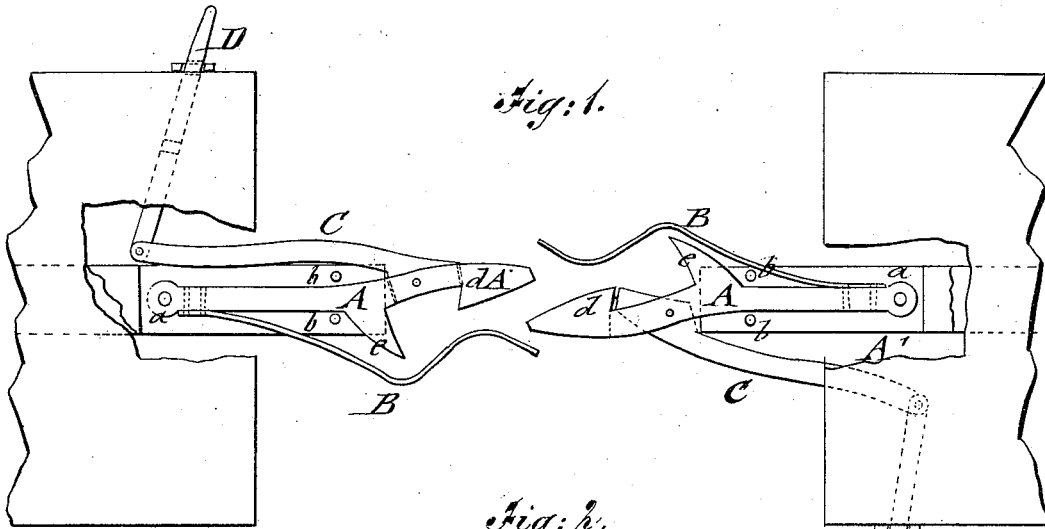

Fig: 1.

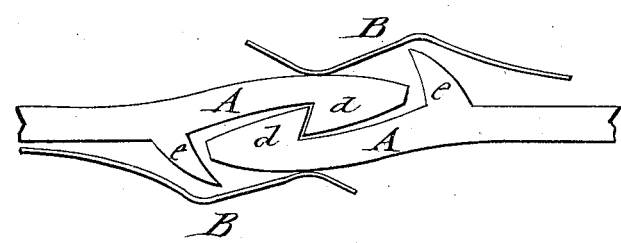

Fig: 2.

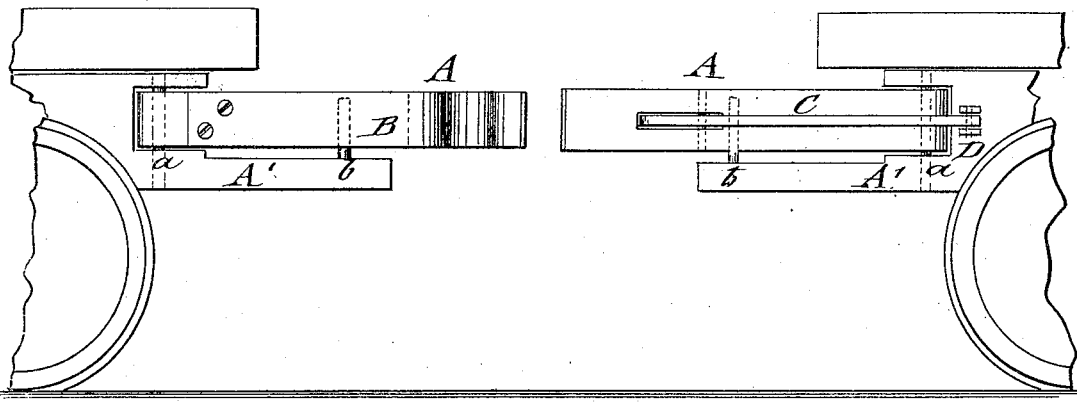

Fig: 3.

WITNESSES:

Chas. Nida
A. F. Terry

INVENTOR:

J. B. Smith
BY *Munn & Co*

ATTORNEYS.

UNITED STATES PATENT OFFICE.

JAMES B. SMITH, OF HEPWORTH, CANADA,

IMPROVEMENT IN CAR-COUPPLINGS.

Specification forming part of Letters Patent No. **169,201**, dated October 26, 1875; application filed August 21, 1875.

To all whom it may concern:

Be it known that I, JAMES B. SMITH, of Hepworth, in the Province of Ontario and Dominion of Canada, have invented a new and Improved Car-Coupling, of which the following is a specification:

In the accompanying drawing, Figure 1 represents a top view of my improved car-coupling in the act of coupling; Fig. 2, a top view of the same in coupled position; and Fig. 3, a side elevation of the same.

Similar letters of reference indicate corresponding parts.

The invention will first be described in connection with drawing, and then pointed out in the claim.

In the drawing, A represents the draw-bar of my improved car-coupling, which is pivoted to a cushioned block, A', attached to the bottom frame of the car in any approved manner. The draw-bar A swings on its pivot-pin *a*, between stop-pins *b* at the front end of the forward-extending block A. The draw-bar has a hook-shaped front end, *d*, and a sidewise-extending spur, *e*, that is curved at the rear side to form a bearing for the band-spring B. The spring B is extended forward to about the length of the draw-bar, and curved inwardly in front of spur *e*, to bear on the front part of the interlocking draw-bar after coupling, and retain the same securely, yet in a yielding manner, as shown in Fig. 2. A lever, C, is pivoted to the recessed front part of the draw-bar, and connected, by a guide-bar, D, pivoted thereto, to the bottom of the car at the side of the same, bar D being recessed to fit into staples or other guide-bearings of the car to retain the draw-bar in coupled or uncoupled position.

By the lever and bar the draw-head may be

carried sidewise for uncoupling, other uncoupling mechanism being provided when the car is to be uncoupled from the top or platform.

When the draw-bars approach each other their front hooks pass alongside of each other, pressing the draw-bars sidewise until the hooks strike the side spurs (acting as buffers) back of the same. The guard-springs B are then called into action, bearing on the draw-head of the opposite coupling, so as to produce the secure interlocking of the hooks, and prevent the uncoupling in connection with the side spurs.

For uncoupling, the front end of lever C is thrown against the hook end of the interlocking draw-bar, which is thereby carried sidewise to clear the hook end, whose lever is operated. The draw-bars may thus be separated without difficulty; and the lever is then carried back again into the recess of the draw-bar, so that the same is ready again for coupling.

When the cars are thrown off the track the draw-bars are instantly detached, and prevent thereby the throwing off of the adjoining cars.

Having thus described my invention, I claim as new and desire to secure by Letters Patent—

An automatic car-coupling, composed of a laterally-swinging draw-bar, with hook end and side spur, a curved guard-spring, extending forward over the spur, and an uncoupling-lever mechanism, substantially in the manner and for the purpose set forth.

JAMES B. SMITH.

Witnesses:

PAUL GOEPEL,
T. B. MOSHER.