

C. S. WESTCOTT.  
Type-Casting and Setting-Machines.

No. 169,215.

Patented Oct. 26, 1875.

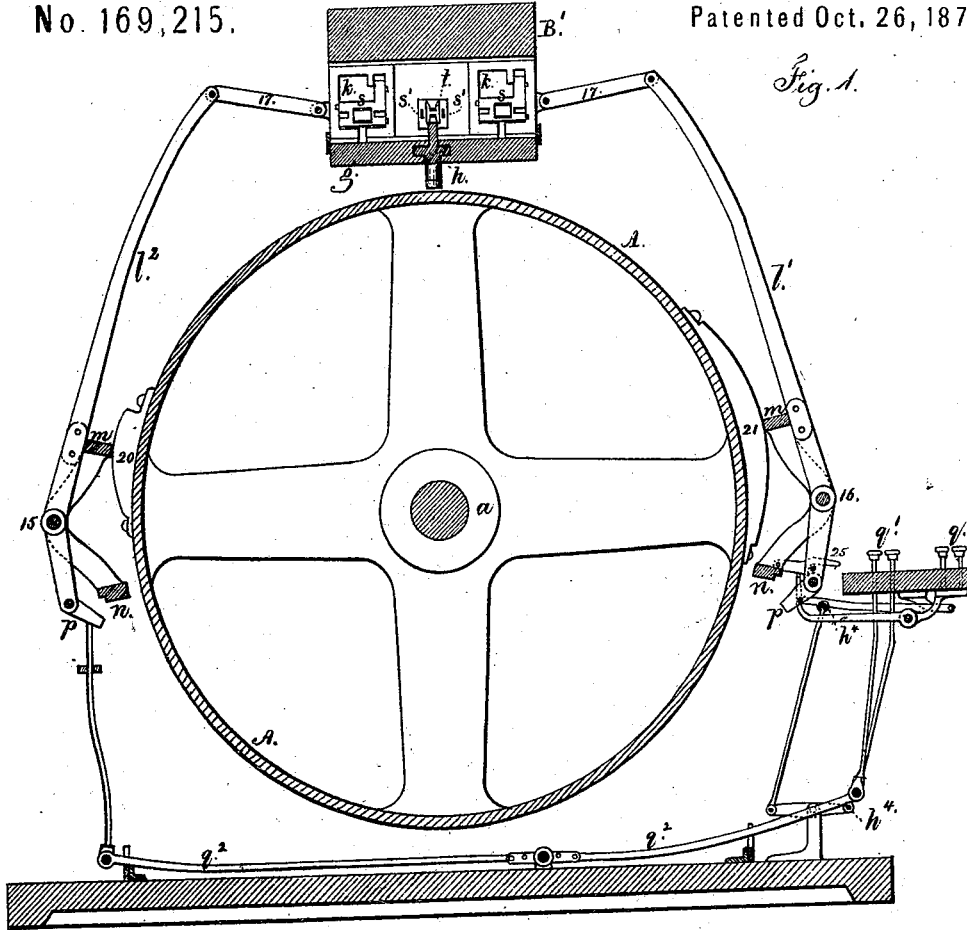

Fig. 1.

Fig. 2.

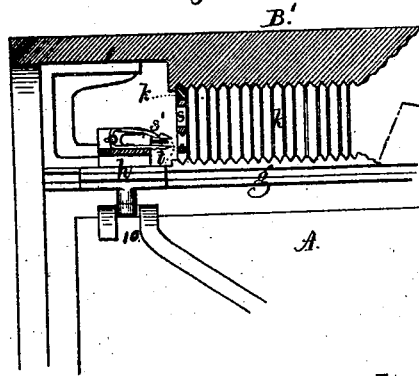
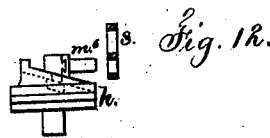
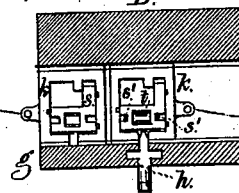

Fig. 3.



Witnesses  
Charles Smith  
Harold Serrell

Inventor  
Charles S. Westcott.  
per Lemuel W. Serrell  
Atty

C. S. WESTCOTT.  
Type-Casting and Setting-Machines.  
No. 169,215. Patented Oct. 26, 1875.

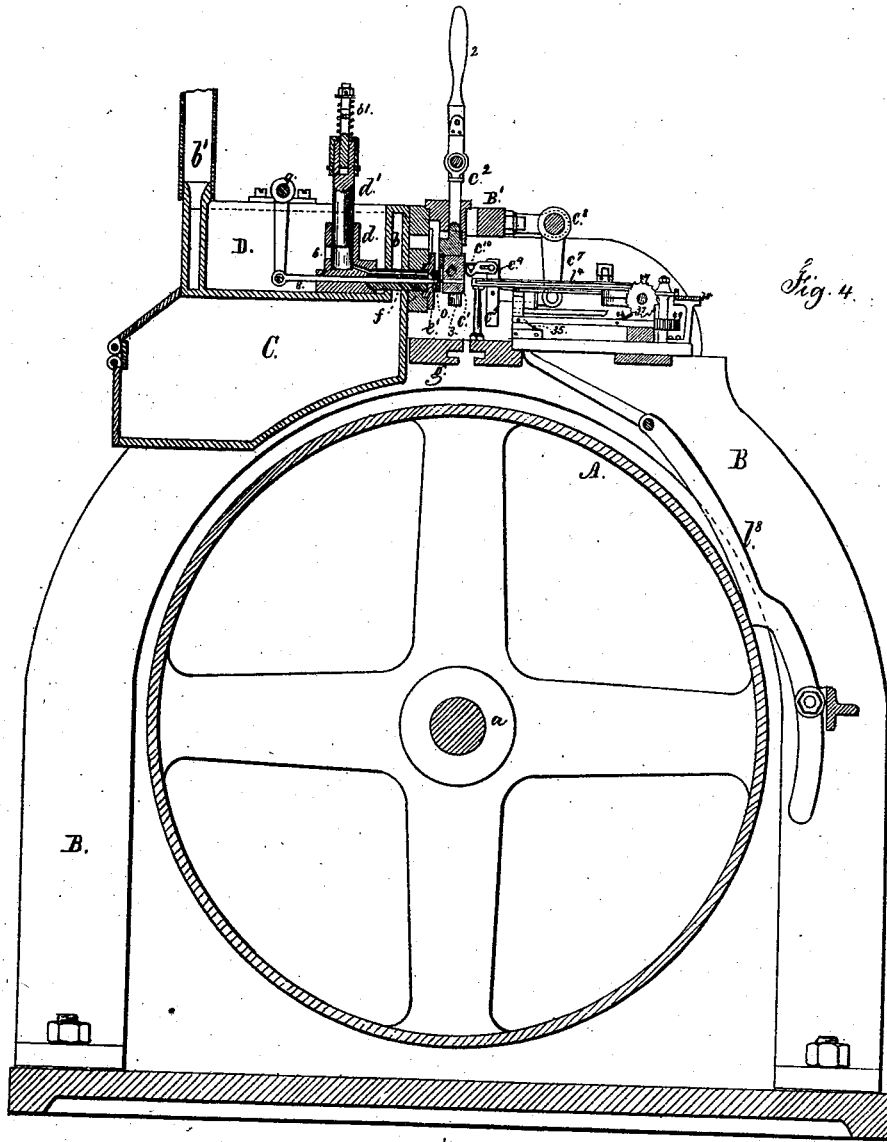

Fig. 4.

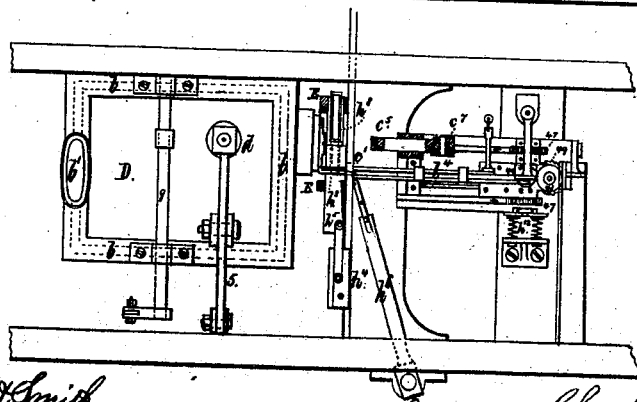

Fig. 5.

Witnesses  
Chas. H. Smith  
Harold D. Jewell

Inventor  
Charles S. Westcott.  
per Lemuel W. Perrell. atty.

C. S. WESTCOTT.

Type-Casting and Setting-Machines.

No. 169,215.

Patented Oct. 26, 1875.

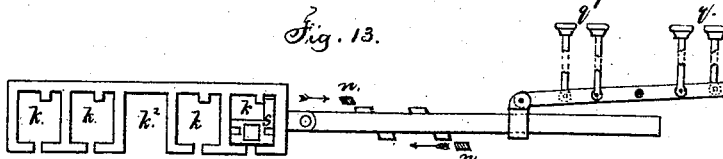
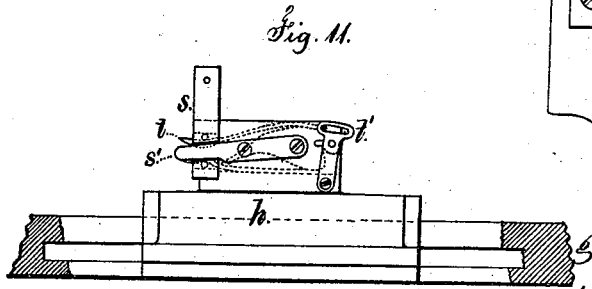
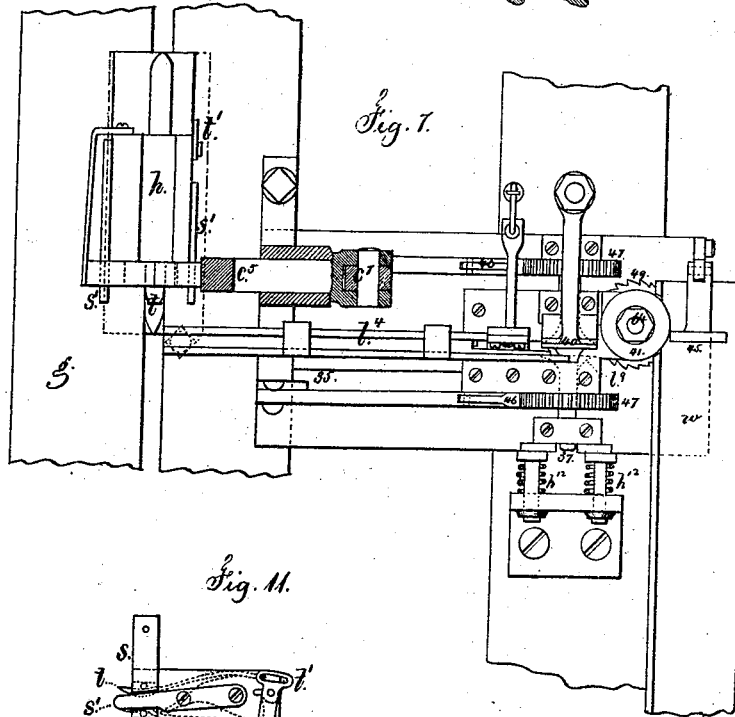
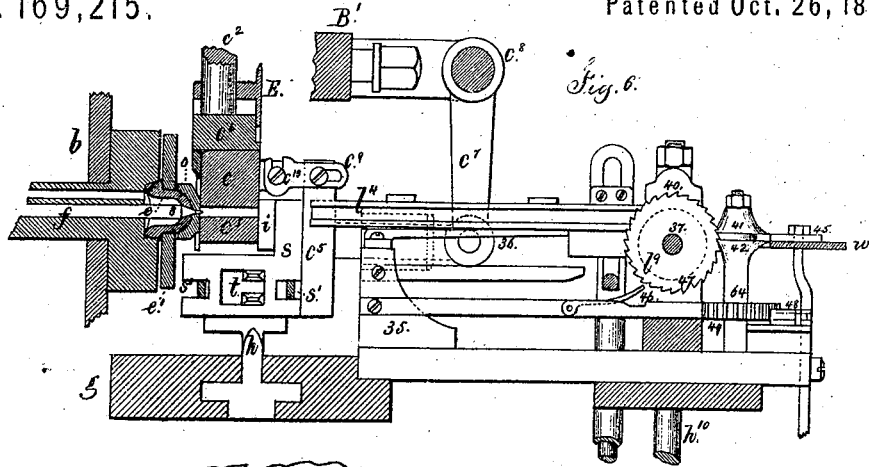

Witnesses  
 Char. A. Smith  
 Harold Serrell

Inventor  
 Charles S. Westcott,  
 per Lemuel W. Serrell atty

C. S. WESTCOTT.

Type-Casting and Setting-Machines.

No. 169,215.

Patented Oct. 26, 1875.

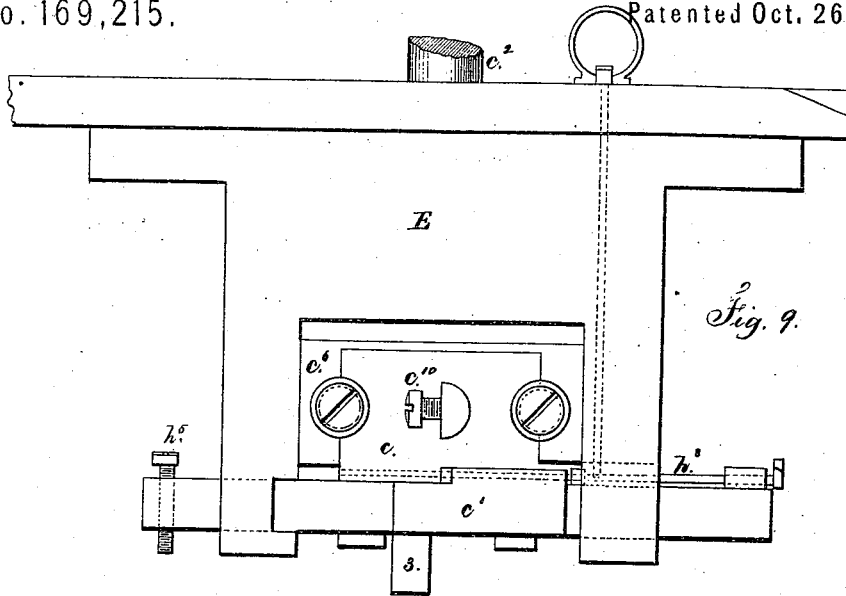

Fig. 9.

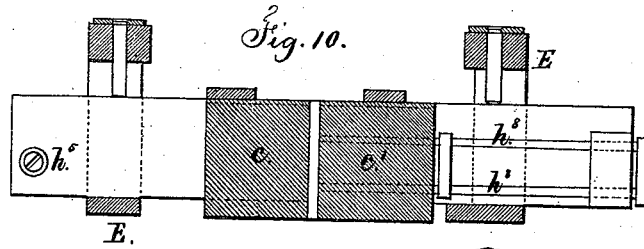

Fig. 10.

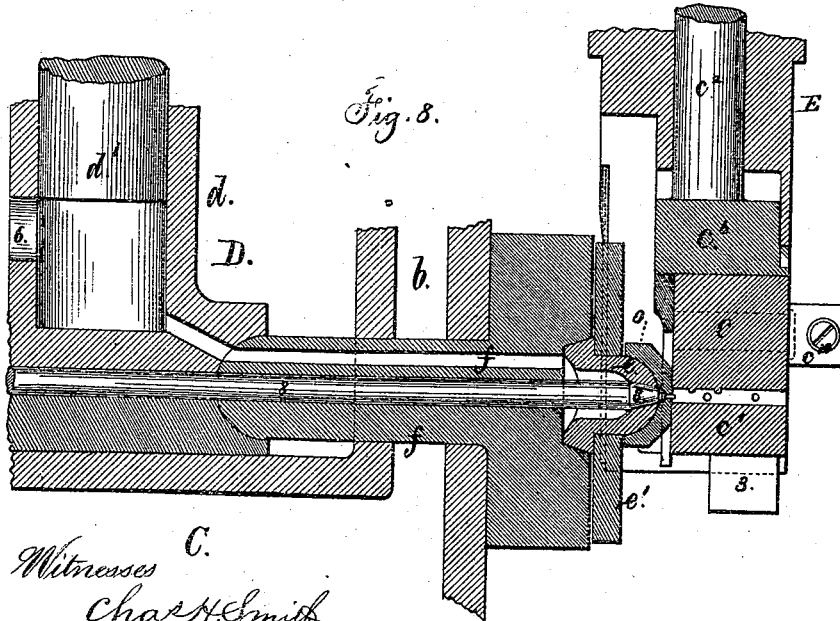

Fig. 8.

Witnesses C.  
 Chas H. Smith  
 Harold Perrell

Inventor  
 Charles S. Westcott.  
 per Lemuel W. Perrell Atty.

# UNITED STATES PATENT OFFICE.

CHARLES S. WESTCOTT, OF ELIZABETH, NEW JERSEY, ASSIGNOR TO THE WESTCOTT'S TYPE-SETTING COMPANY, OF NEW YORK, N. Y.

## IMPROVEMENT IN TYPE CASTING AND SETTING MACHINES.

Specification forming part of Letters Patent No. 169,215, dated October 26, 1875; application filed August 11, 1875.

### CASE A.

*To all whom it may concern:*

Be it known that I, CHARLES S. WESTCOTT, of Elizabeth, in the county of Union and State of New Jersey, have invented an Improvement in Type Casting and Setting Machines, of which the following is a specification:

In Letters Patent No. 115,796 a machine for composing and casting types is set forth. The present invention is an improvement upon the same, and relates to the modifications and additions subsequently applied to said machine. I have shown the machine as it had been modified and improved at the time the English patent No. 2,111, of 1872, was obtained in my behalf, so as to give a full knowledge of the improvements up to that time.

In the drawings, Figure 1 is a cross-section of the actuating cylinder and levers for moving the matrix stocks and frames. Fig. 2 is a section of the matrix-carrier and contiguous parts. Fig. 3 is a transverse section of the stationary slides for the matrix stocks and frames. Fig. 4 is a section of the means for casting the types. Fig. 5 is a plan of the same and of the type-dressing mechanism. Fig. 6 is an elevation, and Fig. 7 is a plan, of the mechanism for dressing the types in larger size. Fig. 8 is a section of the type-molds and casting-jet in about full size. Fig. 9 is an elevation, and Fig. 10 is a sectional plan, of the molds in full size; and Fig. 11 is a detached view of the matrix-carrier.

The main actuating cylinder A is supported upon a shaft, *a*, in a frame, B, and it is rotated by power applied through a pulley, with the required clutch or coupling to connect and disconnect the power. Upon the surface of this cylinder A there are cams attached at the proper places to give the various movements to the respective parts at the proper times.

The shape of the respective cams will be such as to effect the respective movements, and need not be specially described in regard to the shape. There is a pot, D, to contain the type-metal. This is provided with a furnace or heating-chamber, C, in which are, preferably, gas-burners, the heat from which passes up around the pot B into and through

the flues *b b* to the escape-pipe *b'*. The casting mechanism is connected with this pot, and will be next described. The dies *c c'* are within the removable stock E, upon which is a handle, 2, for lifting the dies out bodily from a mortise in the cross-bar B' of the frame. This allows for cleaning and oiling the dies. When in place the stock E is held down by screws or buttons that can easily be turned aside. The upper die *c* is in a frame, *c'*, sliding in the stock E, and these parts are lifted, so as to open the dies in removing the type that is cast. This is done by a cam upon A, acting through a lever that connects with the sliding-rod *c'*, and the handle 2 is at the upper end of this rod. The lower die *c'* is movable lengthwise, and at right angles to the length of the type, so as to vary the width of opening between the shoulders of the molds *c c'*, and thereby determine the thickness of the type according to the letter that is being cast.

The matrix-carrier, hereafter referred to, acts upon the downward projection 3 of *c'* to move the same. The matrix is pressed up against the front of the mold by the slide *c''* that receives motion through the crank-arm *c''* and rock-shaft *c''*, which is actuated by one of the cams on A, and at the same time the mold is pressed against the nipple and shield used in casting, so as to make the joint perfectly tight. When the slide *c''* is drawn back the hook *c'''* that catches upon the screw *c'''* draws the dies back sufficiently to allow the fingers to act that take out the type.

Difficulty has been experienced in casting type without a fin or sprue at the base that required to be broken off. By the means herein described the casting is effected without any sprue, and the nick is made in the lower end of the type, and there is no waste or surplus metal.

The pot D contains the pump *d* that has a piston or plunger, *d'*, operated by a lever, 5, and cam on A, but a spring, 61, intervenes. The plunger *d'* descends until the end passes the hole 6, hence the melted metal will be confined and the spring 61 compressed; and as soon as the valve-plug 8 is withdrawn, which is done at the proper time by a cam acting

through the crank and shaft 9, the melted metal is ejected by the plunger and its spring into the mold, and instantly fills the same, and the plug 8 closes the orifice.

In consequence of the movement of the parts and the expansion under heat it is very difficult to keep the joints between the fountain of melted metal and the molds perfectly tight, for, if they are not, the melted metal will be ejected and obstruct the parts.

To prevent this a removable nipple, *e*, is inserted at the end of the tube *f* for the melted metal. This nipple is retained by a clamping-plate, *e'*, to the head of the tube *f*. The nipple *e* is hemispherical, and upon it rests the shield *o* that is ground to its place upon the nipple, and is steadied by screws passing through wings; but there is enough looseness and play to allow this shield to move slightly by the action of the dies *e* *e'* when pressed back against the shield. Thereby a perfect joint is insured for the dies at the surface of said shield, and the shield rolling upon the nipple allows for whatever slight change of position may become necessary to insure tightness in the joints. The face of this shield *o* is ribbed, and the back of the molds grooved to fit the rib, so that the nick is cast in the back end of the types.

By this construction the jet of melted metal first strikes into the matrix, filling the same, and making a perfect-faced letter, and the entire base of the type is also cast, and there is no sprue or fin, and the point of the valve 8 extends into the foot-nick of the type; hence the metal in the shield is displaced by the valve, and there is nothing remaining upon the base of the type, as heretofore usual in casting types.

In the cross-bar *g* of the frame are grooves, in which slide the matrix-carrier *h*, the same being moved back and forth each complete revolution of the cylinder *A* by a cam, 10, the shape of which is such as to arrest the movement of the matrix-carrier, and hold the same in position during the operation of casting the type; then the matrix-carrier moves back again, drops its matrix, and comes forward, bringing another matrix. In the cross-bars *B'* *g* there are transverse grooves, receiving the frames *k*, and these are as numerous as the letters, figures, or characters employed in the machine, and a letter or character is allotted to each frame, and the frames are connected with corresponding finger-keys. The frames *k* might all be in one line, but they are shown to two rows, one on each side of the opening, in which the matrix-carrier *h* slides. The levers *l* *l'* swing upon the fulcrum-rods 15 16, and they are connected at the upper ends by links 17 to the matrix-frames *k*. The bars *m* *m* extend along between the ranges of levers and the cylinder *A*, and are supported at their ends by arms that swing upon the said fulcrum-rods 15 and 16. The object of the bars *m* is to restore all the levers *l* *l'* and the frames *k* to their normal positions, as shown in Fig. 1,

the cams 20 21 operating upon said bars *m* to move them and the levers outwardly. The bars *n* are moved at the proper time by cams, and act to press in the frames *k* by the levers *l* or *l'*, when one of the dogs *p* is raised by depressing its finger-key *q* or *q'*.

It is to be understood that the levers *l* are acted upon by the keys in the range *q*, and the levers *l'* are acted upon by the keys in the range *q'* through the levers *q'*, and that each lever *l* *l'* has a dog, *p*, hinged to its lower end; hence, when a key is depressed, the corresponding dog is raised, and its end being in the path of the bar *n*, as moved by its cam, gives the motion to the lever *l* or *l'*, and its slide-frame *k*, and in so doing the matrix-stock is brought into the position shown in Fig. 3, in the path of the matrix-carrier *h*, that takes the stock of the matrix out of its frame, and carries it to the mold, where the type is cast, and then brings it back and re-deposits it in its frame *k*.

In order to prevent the machine operating when no matrix is opposite the molds a blank matrix is provided, for casting a space of any desired character, and this is brought into position automatically whenever there is not any matrix in use. To effect this there is upon the bar *n* a hinged finger, 25, (see Fig. 1,) that ordinarily rests upon a pin upon the lever *l* that operates the frame *k* that carries the blank matrix, so that the same will be moved each motion of the bar *n*, except when this finger 25 is raised out of the way of its pin by the depression of one of the finger-keys. This is effected by the finger-key lever acting upon one of the rods *k'* that run above and below the respective ranges of levers, and act upon the said finger 25. The matrix-frames *k* are slotted at the bottom for the passage of the matrix-carrier *h*, and in each frame are notched sockets, in which the matrix-stock *s* hangs by pins in its sides. Upon the carrier *h* are inclines *s'* that pass into openings in the stock *s*, and lift the pins out of the notched sockets clear of the frame *k*, and hold the stock upon the carrier *h*, so as to carry it out of the frame *k*; and to aid in this operation the spring-catches *t* also act in an opening in the stock *s*. The swinging slotted sector *t'* has a screw that applies a sufficient friction to prevent the spring-latches *t* sliding too freely in the matrix-carrier; thereby they are kept in a projected position until they have a firm hold by catching within the opening in the stock. Upon the return movement the spring-latches hold the stock, and the carrier draws back, returning the stock and its pins into the notched sockets in *k*, after which the further movement draws the spring-latches out from this stock, leaving it within its frame.

It will be apparent, from the foregoing, that when a finger-key is depressed its dog *p* causes one of the levers *l* or *l'* to be moved by the bar *n* and cam on *A*. The corresponding frame *k* and stock *s* are moved into the path of the matrix-carrier, and there held while

the carrier removes the matrix and stock, and conveys it to the molds, and the type is cast, and the matrix and its stock returned into its frame, after which the frame *k* is moved back to its normal place by the bar *m* and its cam acting upon the lever *l*<sup>1</sup> or *l*<sup>2</sup>. In bringing up the matrix-stock to the mold the die *c*<sup>1</sup> is closed the proper distance to leave the necessary space for the body of the type. To effect this the stock *s* acts against the downward projection 3, and as each stock has its proper matrix the parts are easily made, so that the stock only gives the proper sliding motion to the die *c*<sup>1</sup>. As the matrix and stock return the die *c* is raised up out of the way, as before described, and a finger, *h*<sup>3</sup>, is moved back in between the dies; then the die *c*<sup>1</sup> is moved endwise by a slide-block, *h*<sup>4</sup>, connected to *c*<sup>1</sup> at *h*<sup>5</sup> and cam on A until the type that rests upon said die *c*<sup>1</sup> is within the finger *h*<sup>3</sup>; then said finger is moved by the arm *h*<sup>6</sup> to draw the type out from between the molds, and convey it into and along in the raceway or slide *l*<sup>4</sup>, from which it is conveyed to the rubbing or dressing mechanism. There are small points formed by the ends of the rods *h*<sup>3</sup>, that project at the side of the mold sufficiently to detain the type in the mold *c*<sup>1</sup> as the mold *c* rises, and therefore present said type to the withdrawing-finger *h*<sup>3</sup>. At the time the type is drawn into the slide *l*<sup>4</sup> the sides of said slide are sufficiently far apart to receive the type, whether it is thick or thin. One side of said slide is moved back for receiving the type, and then allowed to close upon the type by action of the springs *h*<sup>12</sup>, a cam acting against the pendent arm *h*<sup>10</sup> for that purpose. A carriage, 35, is brought up by the lever *l*<sup>8</sup> and its cam, and the finger 36 (see Fig. 6) acts behind the type, so that the type is moved forward between a pair of vertical dish-cutters, *l*<sup>9</sup>, upon the shaft 37, the face of each cutter being accurately in line with the inner side of its respective part of the slide *l*<sup>4</sup>, and the moving side of the slide and the cutter move together, and the slide terminates a little short of the cutters, so that the body of the type will be held by the sides of the slide and the burr around the base of the letter will be cut off accurately as the letter is forced endwise through between said cutters. The holding-blade 40 acts above the type to keep it from rising. The two disk-cutters 41 42 are the same as those before mentioned, but they are fixed at the distance apart that corresponds to the breadth of the type, and stand on a vertical shaft, 64, so as to dress off any burrs that there may be at top or bottom of the letter. The finger or pusher 36 carries each type entirely through between the cutters, and leaves it upon the composing-plate *w* with the letter end toward the operator. The vibrator 45, moved by a cam, presses the entire line of type along from time to time as the cast types are supplied one after another at the end of the line of types in the order of composition. In order to present the different parts of the

cutters to operate upon the types, the shafts 37 and 64 and cutters are moved around progressively by pawls 46 48 and ratchet-teeth 47 and 49.

If desired, the dressing mechanism may be made double, so as to take a type out from first one side of the slide *l*<sup>4</sup> and then from the other by the action of a carriage moving across the slide, there being two pushers, 36, one acting at each side of the slide and carrying the type through between the cutters that dress off the burrs.

It is not deemed necessary or advisable to go into all the details of the shapes of cams and connections from the prime mover or cylinder A. Many of these parts are shown upon the drawing, and they are easily shaped and applied to give the movements and perform the operations specified, and it is remarked that these details and mechanisms may be varied to suit particular arrangements of machines, and they are easily constructed by the competent mechanic.

In Fig. 12, a modification of the matrix-carrier is represented. In this the spring-fingers are dispensed with and a parallel square bar, *m*<sup>6</sup>, with a tapering end, is employed to enter the hole in the matrix-stock *s*, and the block holding this bar is lifted by the incline of the carrier running under it. The reverse movement deposits the matrix-stock in its frame. The bar and stock slide transversely upon the block as the matrix and the mold are pressed up to the casting-shield.

In place of having one matrix in each frame *k*, the frame may be made, as shown in Fig. 13, to contain four matrix-stocks, *s*, and have a central opening, *k*<sup>2</sup>, through which the matrix-stock from other frames is carried. This frame receives a motion either one way or the other by one of two bars, *n*, so as to bring the desired matrix-stock into line, according to which of the finger-keys is depressed. In this case the machine can be more compact, and the finger-keys will be nearly in line with the types as cast—hence, more convenient.

Some of the parts of this machine are capable of use upon or in connection with ordinary type-casting machinery, or for dressing, delivering, or setting up the type in line.

I claim as my invention—

1. The frame *k*, containing four spaces for the matrix-stocks *s*, and a central opening, *k*<sup>2</sup>, through which the matrix-stock from the other frames is carried, in combination with such matrix-stocks and the reciprocating carrier, substantially as set forth.

2. The matrix-stock, provided with pins on its sides, in combination with the frame *k*, having notched sockets, in which the matrix-stock hangs by such pins, and the matrix-carrier that lifts said stock and carries it forward and returns it by the reverse movement, substantially as set forth.

3. The carrier *h*, provided with inclines *s*<sup>1</sup> to lift the matrix-stock, in combination with the spring-catches *t*, substantially as set forth.

4. The casting-nipple *o*, made as a segment of a globe, taking a globular nose, *e*, upon the pot. in combination with the valve 8 that closes the hole in the nipple *o* after the type is cast, substantially as set forth.

5. The combination, in a type-casting machine, of the molds, yielding injecting plunger, nipple at the bottom of the type-mold itself, and a valve in the nipple, withdrawn by mechanism, so that when the valve is closed there is no sprue opening into the mold, and the metal, under a pressure, is projected directly into the matrix to form a perfect-faced type, substantially as set forth.

6. In a type-casting machine, the combina-

tion of the mold with the nozzle or nipple, ribbed and having its jet orifice located described, so as to cast a type with both ends complete, to avoid the channeling or nicking of the foot of the type heretofore necessary.

7. In a type-casting machine, a rib upon the nose or shield of the bath and grooves upon the back surfaces of the molds, to fit such rib, for the purposes set forth.

Signed by me this 9th day of August, A. D. 1875.

C. S. WESTCOTT.

Witnesses:

GEO. T. PINCKNEY,  
CHAS. H. SMITH.