

J. F. GORDON.  
Grain-Binder.

No. 169,258.

Patented Oct. 26, 1875.

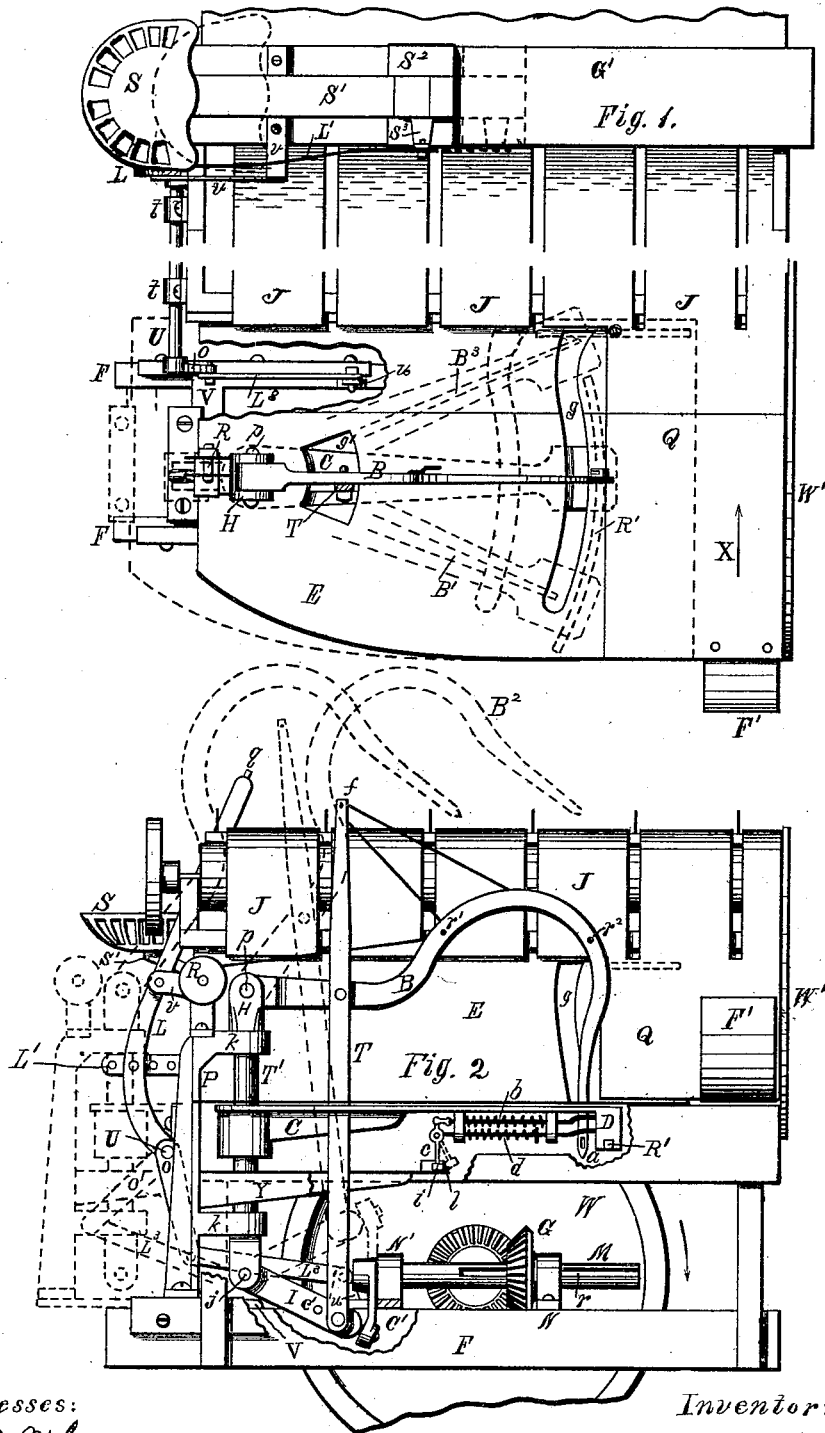

Witnesses:

*C. B. Whitmore*  
*G. B. Selden*

Inventor:

*James H. Gordon*  
*By Wm. Houghton*

J. F. GORDON.  
Grain-Binder.

No. 169,258

Patented Oct. 26, 1875.

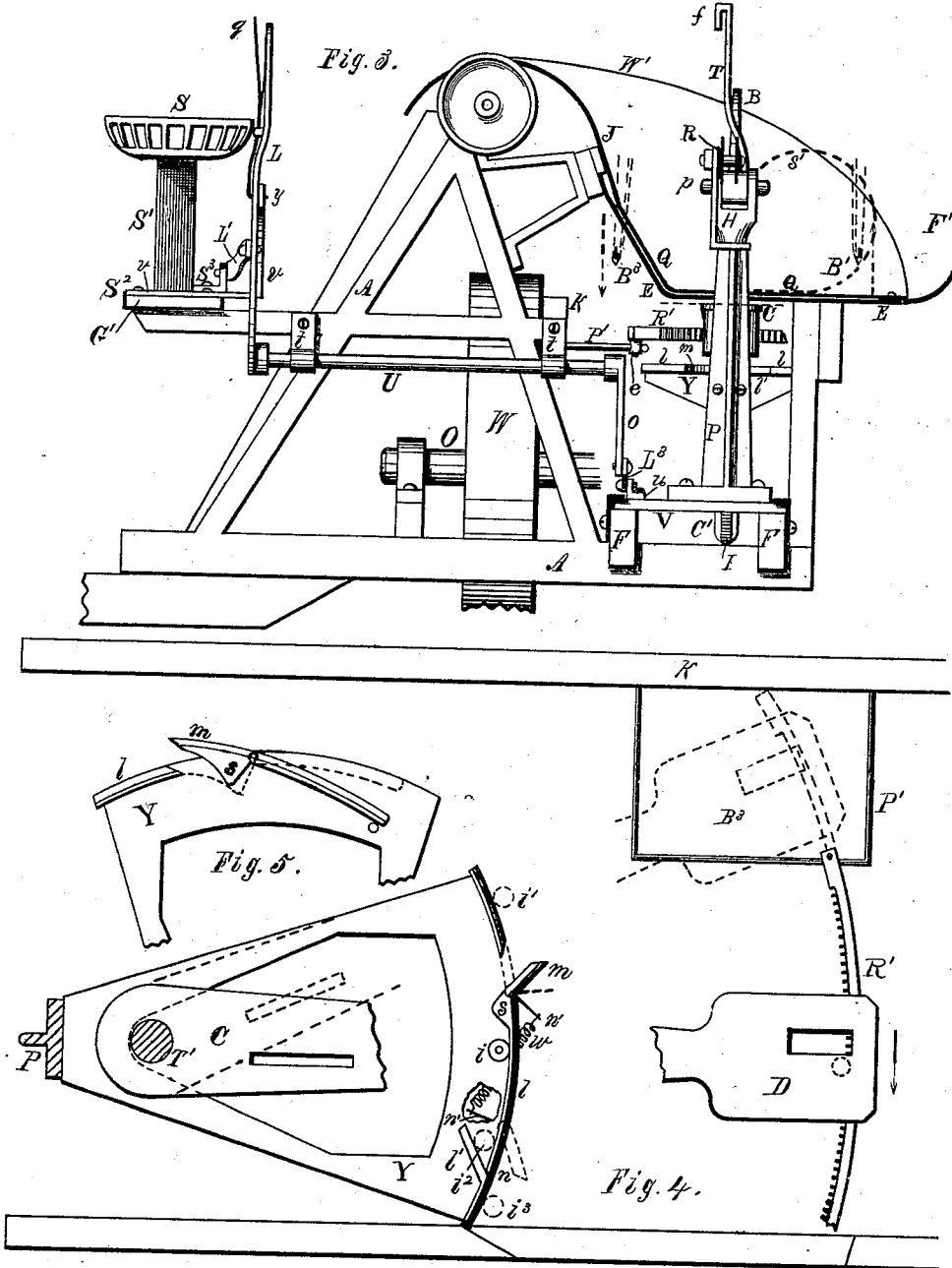

Witnesses:

E. B. Whitmore  
G. B. Selden

Inventor:

James F. Gordon  
By *Wm. C. Coughborough*  
*Att'y*

# UNITED STATES PATENT OFFICE

JAMES F. GORDON, OF ROCHESTER, NEW YORK.

## IMPROVEMENT IN GRAIN-BINDERS.

Specification forming part of Letters Patent No. 169,258, dated October 26, 1875; application filed May 15, 1875.

*To all whom it may concern:*

Be it known that I, JAMES F. GORDON, of Rochester, in the county of Monroe and State of New York, have invented certain new and useful Improvements in Self-Binding Harvesters; and I do hereby declare that the following is a full, clear, and exact description thereof, reference being had to the accompanying drawings, making part of this specification, in which—

Figure 1 is a top or plan view of the binding portion of the machine, together with the adjustable driver's seat, the binder-arm B and twister carrier-arm C being shown in different positions by dotted lines. Fig. 2 is an elevation, looking in the direction of the arrow X in Fig. 1. Fig. 3 is a rear elevation of those portions of the machine to the right of the cutting apparatus, the cutting-platform being broken away. Fig. 4 is a top sectional view, showing the twister carrier-arm and rack R', and the fixed switch-track and its support. Fig. 5 shows a modification of the switches and track on the frame Y.

The object of this invention is mainly to simplify the construction of self-binding grain-harvesters. Its nature will be better understood by reference to the drawings and specification.

In this machine the grain is cut and elevated in substantially the same manner as shown in my former patents of August 27, 1872, and June 16 and 30, 1874; but the binding apparatus, excepting as regards the wire-clamping jaws and twister, is constructed and operated essentially different, as will hereinafter appear.

A, Fig. 3, is a frame, situated at the right of the cutter-platform, which supports the elevating mechanism and binding apparatus. F and F', Figs. 1, 2, and 3, are two parallel horizontal cross-timbers at the right of the driving-wheel W, slightly below and at right angles to the axis of the same, upon which rests the adjustable frame V of the binding apparatus. This frame V is so fitted in ways or guides as to be capable of being adjusted horizontally forward or back by means of a hand-lever, hereafter described. The upright binder post or support P, Figs. 2 and 3, is rigidly secured to the rear end of the frame

V, to the front side of which is hung, in suitable bearings, the vertical axial shaft T', in which it turns. M, Fig. 2, is a horizontal shaft, resting in the boxes N and N', connected with the shaft O, Fig. 3, of the driving-wheel W by the bevel-gears G, Fig. 2. The box N is fastened to the cross-timbers F and F', while the box N' is attached to the sliding or adjustable frame V. The shaft M is provided with a keyway, *r*, in which slides a key, fastened within the hub of the gear G, which hub is nicely fitted upon the shaft, so that it may slide freely upon the same when the frame V is moved, as hereafter described. C' is a crank keyed to the rear end of the shaft M, and I is an oscillating arm, pivoted at one end in a slot in the lower end of the axial shaft T', at a point in line with the axis of the said shaft M, the other end of which arm is journaled in the said crank C', the bearing in the outer end of the revolving crank C' being exactly in line with the compound axial center *j* of the oscillating arm I. The binder-arm B, Figs. 1, 2, and 3, is pivoted, by the horizontal pin *p*, in a slot in the upper end of the axial shaft T', by which its vertical movements are permitted. The carrier-arm C is rigidly fixed to the axial shaft T', under the said binder-arm, and contains within its head D the twister, and underneath the wire-clamping jaws *b* and *d*, Fig. 2.

The sliding shield E, Figs. 1, 2, and 3, is attached to the binder-post P, with which it moves. This shield, at one end, slides under the fixed shield Q, and is composed of an inclined and a horizontal portion, as shown in Fig. 3, the latter of which is arranged slightly above the carrier-arm C, while the former bends up and laps under the downward-curved ends of the slats J. Through the shield E there is a segmental opening, *g'*, in which the bar T moves; also, a narrow sinuous slot, *g*, in which the outer end of the binder-arm plays while encircling the gavel with the wire and binding the same.

The bar T being movably attached to the oscillating arm I and binder-arm B, as shown in Fig. 2, it will be easily understood that, as the shaft M is made to revolve, the binder-arm will be carried alternately up and down, and to the right and left, the extreme point *a*

of which will describe nearly the outline of a vertical oval—that is, when the crank *C* stands downward, as shown in full lines in Fig. 2, the binder-arm will occupy the position shown in full lines in Figs. 1, 2, and 3, the point of the same, carrying the binding-wire, appearing at *a*, Fig. 2. When the crank swings out, reaching horizontally away from the wheel *W*, the binder-arm will be in the position shown by dotted lines at *B*<sup>1</sup> in Figs. 1 and 3; when the crank stands upward, as shown by dotted lines in Fig. 2, the binder-arm will be in the position shown by dotted lines at *B*<sup>2</sup>; and when the crank reaches horizontally toward the wheel *W*, the resulting position of the binder-arm will be as shown by dotted lines at *B*<sup>3</sup>, Figs. 1 and 3, one complete circuit of the point of the binder-arm, as described, being necessary and sufficient to encircle with the wire and bind each gavel.

In this machine I design to revolve the twister by means of the segmental rack *R*, Figs. 1, 2, and 3, passing through and resting movably within the head *D* of the carrier-arm *C* in a horizontal position. This rack is bent to correspond to an arc of a circle having its center in the axis of the axial shaft *T*, and is provided, at its inner end, with a concave-faced roller, *e*, Fig. 3. The rod or bar *P*, Figs. 3 and 4, is bent in two right angles, lying horizontally and immediately under the end of the rack, with its ends fixed to the timber *K*, which forms a stop for the said rack. Commencing with the carrier-arm at the extreme left, as shown by dotted lines at *B*<sup>3</sup>, Figs. 1 and 4, with the end of the rack in contact with the timber *K*, as the said arm moves away from the said timber *K*, the rack being carried with it, there is no motion of the twister till the roller *e* has reached the stop *P*, when the movement of the rack is arrested, and the twister immediately set revolving by the onward movement of the carrier-head *D*. This revolving of the twister continues till the carrier-arm ceases its motion to the right, and as it returns again, carrying the rack with it, the twister ceases to revolve, and remains at rest till the end of the rack is again brought in contact with the timber *K*, when the twister is revolved backward by the continued movement of the head *D*. The ends of the stop *P* may be threaded for a considerable distance, and passed through the timber *K*, with a nut on each side of the same, by means of which the stop may be gaged—that is, lengthened out or shortened up so as to regulate the length of the period during which the twister shall remain at rest at each vibration of the carrier-head *D*.

The wire-clamping jaws *b* and *d*, Fig. 2, are operated by means of the roller *i*, journaled at the lower end of the lever *c*, traversing the curved track *l*, Figs. 2 and 4. This track is supported by the switch-frame *Y*, reaching out horizontally under the carrier-arm *C* from the binder-post *P*, to which it is rigidly fixed. The switches *m* and *n*, Fig. 4, are detached

short portions of the track *l*, pivoted so as to swing horizontally open or shut, and when closed form part of the continuous track *l*. *n*' and *n*' are pins projecting, one forward and the other back, from the lower end of the pivotal stems of the switches *m* and *n*, connected by the spiral spring *w*.

It will be understood that by means of the spring *w* the normal position of the switches is effected, *m* being open and *n* closed.

When the carrier-arm *C* stands to the left, as shown by dotted lines *B*<sup>3</sup> in Fig. 4, the roller *i* will occupy the position shown by the dotted circle *i*<sup>1</sup>. As the said arm moves in the direction indicated by the arrow, the switch *m* being open, the roller will pass through to the concave side of the track *l*. When said roller has reached the short auxiliary track *l*', as shown at *i*<sup>2</sup>, it will roll outward along the same, forcing the switch *n* open against the action of the spring, and will occupy the position indicated by the dotted circle *i*<sup>3</sup> when the head *D* has moved to the extreme point in that direction. The switch *n* closes immediately upon the exit of the roller, and a continuous track is formed, along the convex side of which the roller moves during the return vibration of the carrier-arm, the roller forcing the switch *m* closed as it passes over it to its former position at *i*<sup>1</sup>. Near the switch *m*, on the inside of the track, there is an angular projection, *s*, over which the roller *i* passes, the effect of which is to temporarily open the lower jaw *d*, Fig. 2, and release the end of the wire after being severed, which is to form the next band. The extent of vertical throw of the binder-arm *B* may be changed by changing the point of attachment of the bar *T* to the oscillating arm *I*—as, for instance, to *d*, to lessen the throw. The bar *T* is extended to some distance above the binder-arm, to *f*, forming a take-up for the wire, which is supplied from the reel *R*, suitably located near the top of the binder-post *P*. The bar *T* being thus connected, the take-up *f* is caused to change its relative position with reference to the reel *R* and the points *r*<sup>1</sup> and *r*<sup>2</sup> on the binder-arm as the latter is making its vertical movements in binding the grain.

The driver's seat *S* is attached to the upper end of the inclined seat-bar *S*<sup>1</sup>, Figs. 1, 2, and 3, fastened to the adjustable clasp *S*<sup>2</sup>, Figs. 1 and 3, to the horizontal bar *G*, resting upon projections of the frame *A*. *U* is a horizontal rock-shaft resting in boxes *t*, attached to the rear of the frame *A*. The lever *L* is keyed to one end of the shaft *U*, and extends upward in position for convenient manipulation by the driver at any time, even during the movement or operation of the machine. It is connected, by the link *L*<sup>1</sup> and bracket *S*<sup>3</sup>, to the adjustable clasp *S*<sup>2</sup>. The crank-arm *o*, keyed to the other end of said shaft, reaches downward, and is connected, by the link *L*<sup>2</sup>, to the bracket *u*, which is fastened to the adjustable frame *V*. By this arrangement the driver, by

throwing the lever L forward, may move at once the whole binding mechanism, together with the sliding shield E, back to occupy the position represented by dotted lines in Fig. 2. This adjustment of the binding mechanism is found to be necessary on account of the varying length of grain; also on account of the different manner in which the grain falls upon the platform in going up and down hill. In cutting up hill the grain falls farther back on the platform, while in cutting down hill it falls nearer to the front of the same, and the binding mechanism has to be correspondingly adjusted. When the lever L is thrown forward, as above described, the driver's seat is carried forward with it, in which position the weight of the driver and seat compensates for the weight of the binding mechanism in the corresponding rear adjustment. By this arrangement the machine is kept reasonably balanced at whatever position it may be found necessary to adjust the binding apparatus. It may be found desirable to attach the grain-reel to the lever L in such a manner that it shall have an adjustment forward or back corresponding with that of the driver's seat. By this arrangement the driver may adjust the reel, as well as the binding mechanism, to correspond to different lengths of grain, and "the lay" of the land over which the machine may pass.

The link L', as shown in Fig. 2, is provided with several holes, so that its connection with the lever L may be adjusted to suit the weight of different men that may occupy the driver's seat.

It might be found desirable to retain the adjustability of the seat S independent of the adjustable binding apparatus, or vice versa, in which case they might be disconnected.

The segmental bar *v* is bolted to the support G', Figs. 1 and 3, under the seat-bar S', and pierced at various points with holes, in which the end *y* of the latch *g* may enter. This latch thus locks the lever L, to correspond to any desired position of adjustment of the binding mechanism or driver's seat, or both, as above described.

Instead of combining the movable seat with the binding mechanism, and having the weight of the driver serve as a counter-balance to the binder, any other adjustable counter-balance may be employed.

The strip F', Figs. 1, 2, and 3, is attached to the fixed shield Q, forming a sort of a detent to prevent the butt of the bundles from swinging off the machine in advance of the heads, as is found to be the tendency.

The wind-board W', Figs. 1, 2, and 3, is employed in this machine substantially in the same manner as represented in my former patents, above mentioned. The position of the wire upon the gavel, while being twisted, is shown by the heavy dotted circle *s'*, Fig. 3.

The oscillating arm I, Fig. 2, may be attached rigidly to the axial post or shaft, T', extending out horizontally toward the shaft

M, and be acted upon by a suitable cam, instead of the crank C', as shown, to move the said axial shaft T'; and by extending the rear end of the binder-arm through the head H, and causing it to move in a suitably-curved slot, the desired vertical movements of the same may be produced, instead of using the connecting-bar T, as shown.

It may be found desirable to mount the driver's seat S upon an arm, and cause it to swing by the action of the lever L, instead of sliding, as shown.

The rack R' may be made straight instead of curved, as shown, by increasing the diameter of the roller *e*, so as to project beyond the end of said rack, whereby it may roll upon the timber K and stop P' as the arm C is making its vibrations.

If desired, the binding apparatus might be hung to the timber K, and the inner timber or cross-sill F, instead of the two cross-sills F and F', as shown, in which case the outer one, F', might be dispensed with.

I use the clutch for throwing the working portions out of gear with the drive-wheel, the same as shown in the patents of June 16 and 30, 1874, before mentioned.

It will be seen that all the movements of the binding apparatus are produced by the crank C'. This is very desirable, as it permits the construction of the machine to be greatly simplified, and the parts all timed together, so as to produce a definite and fixed coaction.

What I claim as my invention is—

1. The vertically-reciprocating binder-arm B, hinged to a vertical axial shaft, T', or its equivalent, in combination with a movable twisting mechanism, substantially as shown and described, whereby the arm is given a horizontal oscillation laterally across the grain, in combination with its vertical reciprocation, for the purposes set forth.

2. In combination with the vertical axial shaft T', or its equivalent, binder-arm B, and twisting mechanism, having a reciprocating motion, the oscillating arm I, substantially as and for the purposes described.

3. In combination with a binder-arm, B, reciprocating binding mechanism, shaft T', or its equivalent, and arm I, the connecting-rod T and crank C', or its equivalent, substantially as and for the purposes described.

4. In combination with the reciprocating binder-arm B and vertical axial shaft T', the swinging arm C, substantially as shown and described.

5. In combination with the stationary shield or sheathing, the sliding or extension shield E of the movable binding mechanism, substantially as and for the purpose described.

6. In combination with the movable seat and movable binding mechanism, the rock-shaft U, hand-lever L, and arm O, substantially as and for the purpose described.

7. The combination, in a grain binding and harvesting machine, of a movable binding

mechanism and a movable driver's seat, or equivalent, connected in such manner that their simultaneous adjustment in opposite directions is effected, substantially as and for the purpose described.

8. In combination with the traversing roller *i*, operating the wire-clamping jaw or jaws, the stationary track *l*, provided with the pivoted switch tongue or tongues, substantially as shown and described.

9. In combination with the main frame of a harvesting-machine, a driver's seat, movable forward and backward in relation to the axis of said frame, and a hand-lever connected with said seat, substantially as shown and described, so that the driver, while occupying the seat, can shift the same by means of the lever, as may be required, without affecting the cutting devices.

10. In combination with the fixed box *N* and fixed driving-gear *G*, the movable binding mechanism, having its driving-shaft *M* arranged to slide through the gear *G*, as shown and described.

11. The connecting-rod or pitman *T*, extended beyond the point at which it is pivoted to the binding-arm, for the purpose of forming a take-up for the wire.

12. In combination with the moving binding devices, the detent *F'* at the outer corner of the shield or sheathing, substantially as shown and described, for the purpose of detaining the butts of the grain.

JAMES F. GORDON.

Witnesses:

WM. S. LOUGHBOROUGH,  
E. B. WHITMORE.