

E. MORGAN.

Feeding-Mechanism for Grain-Drills.

No. 169,283.

Patented Oct. 26, 1875.

FIG. 1.

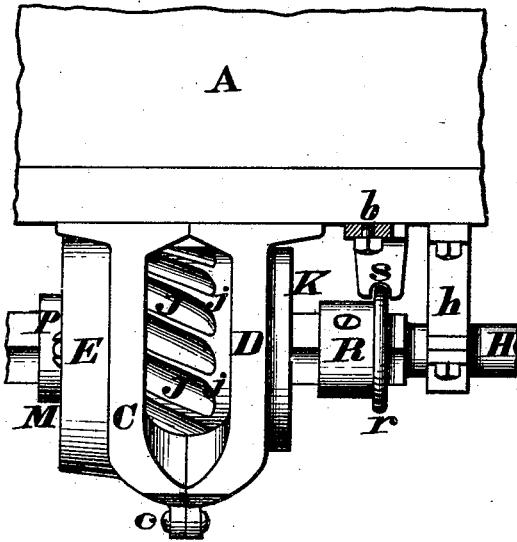

FIG. 2.

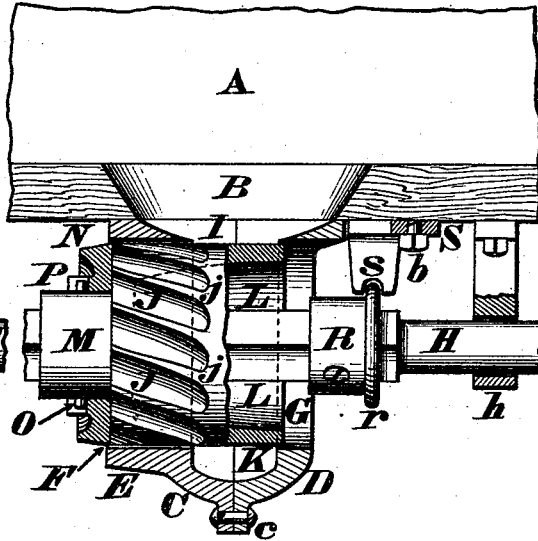

FIG. 3.

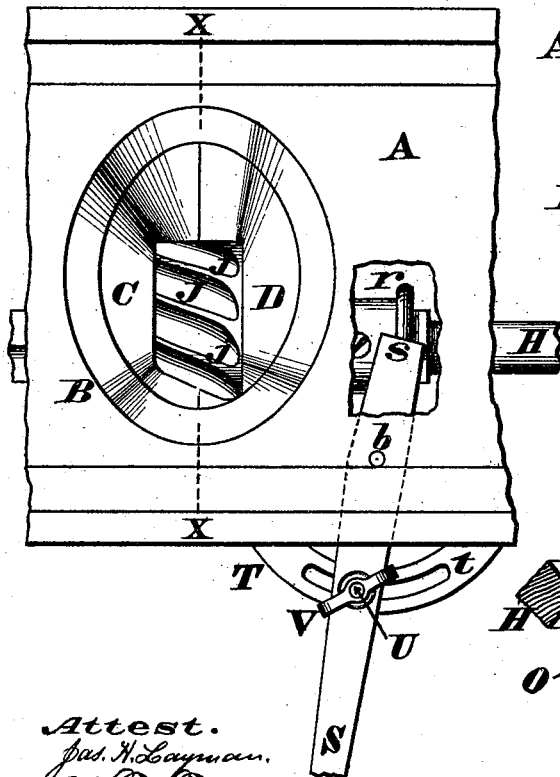

FIG. 4.

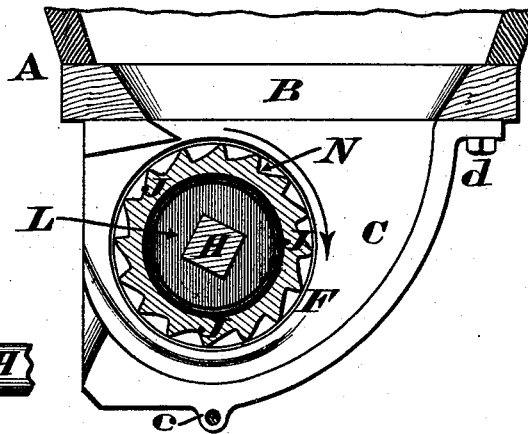
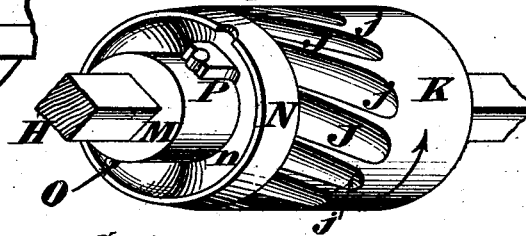

FIG. 5.



Attest.  
Wm. H. Layman.  
Chas. F. Tanner.

E. Morgan  
By Knight & Sons Attys.

# UNITED STATES PATENT OFFICE.

EDMOND MORGAN, OF DUBLIN, INDIANA, ASSIGNOR TO HIMSELF AND  
WAYNE AGRICULTURAL COMPANY, OF SAME PLACE.

## IMPROVEMENT IN FEEDING MECHANISMS FOR GRAIN-DRILLS.

Specification forming part of Letters Patent No. **169,283**, dated October 26, 1875; application filed  
May 25, 1874.

*To all whom it may concern:*

Be it known that I, EDMOND MORGAN, of Dublin, Wayne county, Indiana, have invented certain new and useful Improvements in Feeding Mechanism for Grain-Drills, of which the following is a specification:

The object of my invention is to provide a wallower or feed-wheel that will insure a regular and uniform delivery of grain from the hopper of a drill or other similar implement, and at the same time be capable of adjustment, so as to discharge a greater or less quantity of seed, as may be desired, and I accomplish this result in the following manner:

My feed-wheel proper consists essentially of a cylindrical casting, about two inches in diameter and nearly the same number of inches in length, said casting being provided with spiral grooves, corrugations, or flutes. These corrugations do not extend along the entire length of the cylinder, but proceed from one end to about the midlength of the wheel, at which point they gradually die or shoal out, so as to form no abrupt shoulders at their terminations. This spirally-corrugated wheel is keyed to a feed-shaft, and journaled within any approved form of seed-cup in such a manner as to be capable of adjustment within the same, by shifting the aforesaid feed-shaft lengthwise. When this shaft is shifted so as to bring the entire corrugated surface of the wheel within the seed-cup, the maximum feed is obtained; but by sliding said shaft in an opposite direction, so as to introduce more or less of the smooth periphery of the cylinder into the seed-cup, instead of the corrugated portion, the discharge of grain can be reduced at pleasure until the minimum feed has been secured.

Having thus briefly indicated the principal features of my invention, I will now proceed to give a detailed description of the same.

In the accompanying drawings, Figure 1 is an elevation of the rear or delivery end of a seed-cup provided with my improved form of wallower, the latter being set so as to discharge a moderate quantity of grain. Fig. 2 is a vertical section of the same in the plane of the feed-shaft, the wallower being adjusted so as to discharge the smallest possible quan-

tity of grain. Fig. 3 is a plan of the feed-wheel and its accessories, said wheel being set to discharge the maximum quantity of grain. Fig. 4 is a transverse section through the seed-cup at the line X X; and Fig. 5 is a perspective view of the feed-wheel detached from its inclosing-cup.

A represents a portion of the hopper of a grain-drill, and the bottom board of said hopper is pierced with an elliptical aperture, B, to permit descent of grain into the seed-cup. This seed-cup, which is secured to the hopper, is composed of two almost precisely similar members, C and D, that are united together by a rivet, *c*, and attached to said hopper by bolts or screws *d*. The member C of the feed-cup has, projecting from its exposed side, an enlargement or boss, E, which boss and said member C are so formed as to present, when united, a circular aperture, F, of sufficient size to receive the wallower of the implement. The opposite member D of the feed-cup is pierced with a similar circular aperture, G, of the same diameter as the one F, and in line with it. The feed-shaft H is journaled in suitable bearings *h*, and has the usual geared connection with one of the ground-wheels of the implement. Securely attached to this shaft, so as to rotate therewith, is my feed-wheel or wallower, which consists of a cylindrical casting, I, about two inches in diameter, and an inch and three-quarters in length, although these proportions may be varied to suit different-sized implements. This feed-wheel is provided with spiral grooves or corrugations J, which may have any suitable pitch. Said grooves or flutes extend from one end of the cylinder to about the midlength of the same, where they gradually shoal out at *j*, thereby avoiding sharp angles or shoulders that would be liable to cut and injure the seed. The remaining periphery of the feed-wheel is smooth or uncorrugated, as shown at K. The wheel is preferably chambered out, as at L, so as to diminish its weight, which is quite a consideration where a number of such wheels are employed. The corrugated portion of the wallower is provided with a hub, M, which passes through a circular aperture, *n*, of a disk, N, the latter being of the same diameter as the

feed-wheel. This hub is secured to the shaft H by a pin, O, which is inserted between lugs P of the disk N, so as to compel said disk and the wheel I J K to rotate in unison with each other.

The disk N can be detached in a few minutes, whenever it is desired to dress out the corrugations J, and by making said disk a separate member from the feed-wheel it facilitates the casting of the grooves or flutes.

In order to render the shaft H, together with its attachments I, J, K, M, and N, capable of longitudinal adjustment either to the right or left, said shaft has secured to it a collar, R, whose annular flange or rib *r* engages with a clutch, *s*, at the inner end of a shifting-lever, S, the latter being pivoted to the hopper at *b*. T is a bar or plate, having a curved slot, *t*, which is concentric with the pivot *b*, and said slot receives a screw or bolt, U, with whose upper end a thumb-nut, V, engages.

This provision of the lever S, together with its accessories T, *t*, U, and V, enables the shaft A to be maintained at any desired adjustment.

The operation of my feeding mechanism is as follows: When it is desired to deliver a moderate quantity of grain, the shaft H is shifted so as to cause a portion of the smooth periphery K and of the corrugated periphery J of the wallower I to be brought within the feed-cup C D, as shown in Fig. 1, and the supply of grain can be reduced to a minimum by shifting the wheel farther to the left, as seen in Fig. 2. To deliver the largest quantity of grain, the shaft H is shifted so far toward the right as to introduce the entire corrugated surface of the feed-wheel within the seed-cup, as represented in Fig. 3.

The operation of the wallower is the same whether it be set to deliver a large or small

quantity of grain, or any intermediate amount, and it will be readily understood that as said wallower rotates in the direction indicated by the arrows in Figs. 4 and 5, the corrugations J act to deliver the grain in a regular and uniform manner. These corrugations being arranged in a spiral manner, and free from angles or abrupt shoulders, they conduct the grain to the delivery end of the cup in a gradual manner and without crowding, bruising, or otherwise injuring it. As it is the grooves J alone that cause the wheel I to feed, it will be readily understood that the delivery of grain will be exactly in proportion to the corrugated surface of said wheel that is brought to bear within the seed-cup.

It will be seen that the obliquity of the corrugation operates to crowd the grain away from the deep end where only it would be liable to choke and cut, and by this means the device is constantly maintained in condition for free working, and without destruction of the seed.

I claim as my invention—

1. The cylindrical feed-wheel having one-half spirally grooved, as and for the purpose set forth.

2. The feed-wheel or wallower I, constructed with a smooth periphery, K, and spiral corrugations J, in combination with the shaft H, flange *r*, clutch *s*, adjusting-lever S, and clamp U V, as and for the purposes specified.

3. The combination of the hub M, disk N *n*, pin O, lugs P P, and shaft H, as specified, for the purpose set forth.

In testimony of which invention I hereunto set my hand.

EDMOND MORGAN.

Attest:

GEO. H. KNIGHT,  
HARRY KNIGHT.