

J. G. RALPH.

Connecting Spirit-Level and Straight-Edge.

No. 169,290.

Patented Oct. 26, 1875.

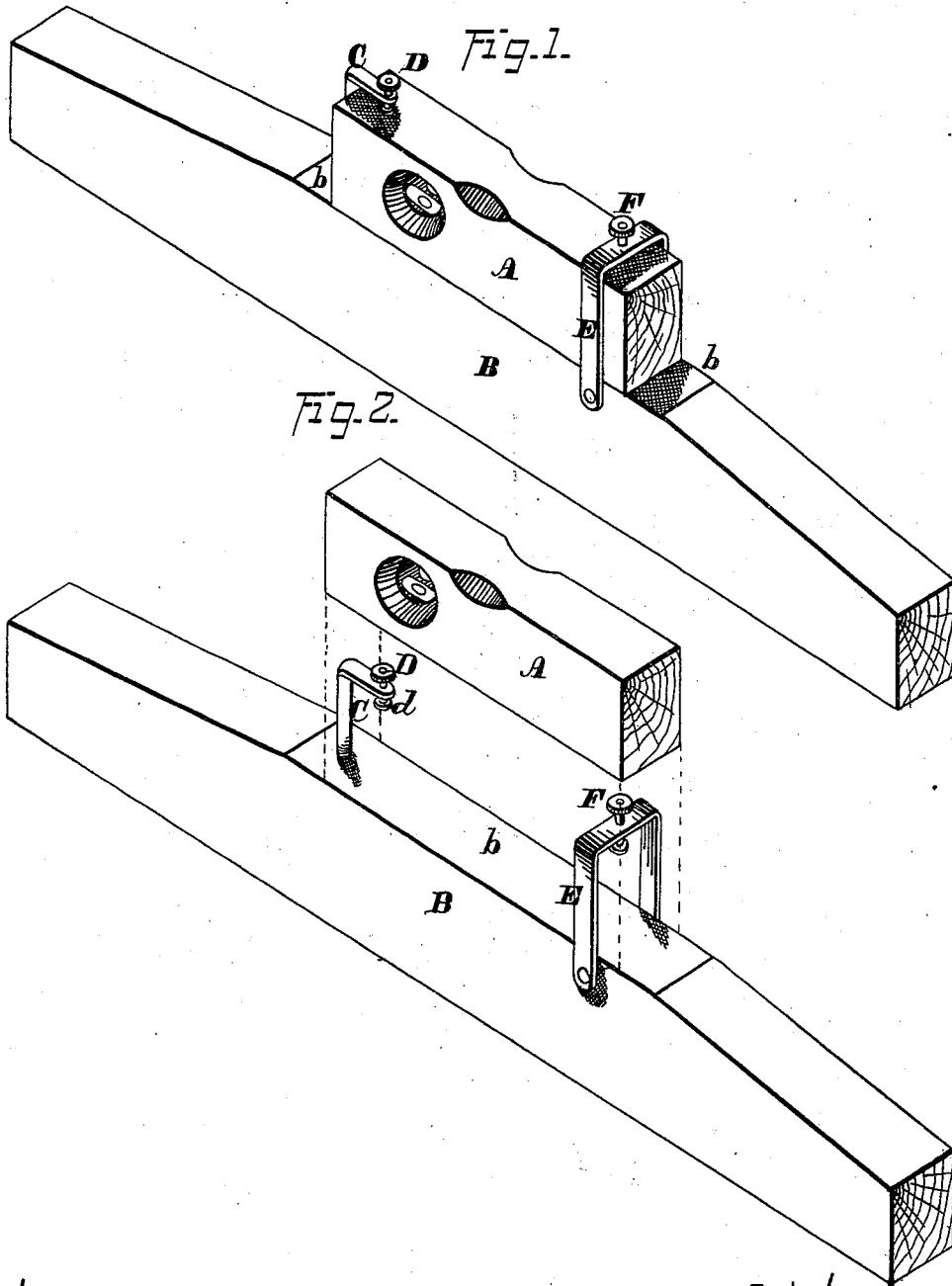

WITNESSES=  
 *Jas. C. Hutchinson.*  
 *John R. Young*

INVENTOR.  
 *James G. Ralph, by*  
 *Prindle and Co. his Attys*

# UNITED STATES PATENT OFFICE.

JAMES G. RALPH, OF AURORA, ILLINOIS.

## IMPROVEMENT IN CONNECTING SPIRIT-LEVELS AND STRAIGHT-EDGES.

Specification forming part of Letters Patent No. **169,290**, dated October 26, 1875; application filed August 21, 1875.

*To all whom it may concern:*

Be it known that I, JAMES G. RALPH, of Aurora, in the county of Kane, and in the State of Illinois, have invented certain new and useful Improvements on Attachments for Connecting together Spirit-Levels and Straight-Edges; and do hereby declare that the following is a full, clear, and exact description thereof, reference being had to the accompanying drawing, making a part of this specification, in which—

Figure 1 is a perspective view of a spirit-level and straight-edge combined by means of my improved device, and Fig. 2 is a like view of said parts separate from each other.

Letters of like name and kind refer to like parts in each of the figures.

The design of my invention is to enable a spirit-level to be easily and securely combined with a straight-edge; to which end it consists in the means employed for connecting together said parts, substantially as and for the purpose hereinafter specified.

In the annexed drawings, A represents a spirit-level, and B a straight-edge, both of usual form and construction. Upon or within the back edge *b* of the straight-edge B, at one side of its longitudinal center, is secured a metal rod, C, which extends outward at a right angle therewith, and has its end bent inward upon a line parallel to said edge, and within a threaded opening in said end is provided with a set-screw, D. At a suitable point upon the opposite side of the longitudinal center of the straight-edge B from the rod

C is a metal strap, E, which, at its ends, is pivoted to or upon the sides of said straight-edge, extends upward to a height corresponding to the height of said rod, and, like the latter, is provided with a set-screw, F, which extends inward through a threaded opening that is formed in the outer end of said strap.

The spirit-level A is now placed upon the straight-edge, one end being contained within the strap E, while its opposite end is in contact with the inner side of the stud C, and beneath the bent end of the same, after which, by turning inward upon the screws D and F, said spirit-level will be firmly secured to or upon said straight-edge.

In order to prevent the points of the screws D and F from bruising the spirit-level, each of the former has pivoted thereon a button, *d* and *f*, respectively, which alone comes into contact with said level.

Having thus fully set forth the nature and merits of my invention, what I claim as new is—

In combination with the spirit-level A and straight-edge B, the stud C, strap E, and set-screws D and F, substantially as and for the purpose specified.

In testimony that I claim the foregoing I have hereunto set my hand this 8th day of June, 1875.

JAMES G. RALPH.

Witnesses:

GEO. S. PRINDLE,  
J. B. CALLAN.