

A. M. SOUTHARD.
Corn-Planter.

No. 169,307.

Patented Oct. 26, 1875.

Fig. 1.

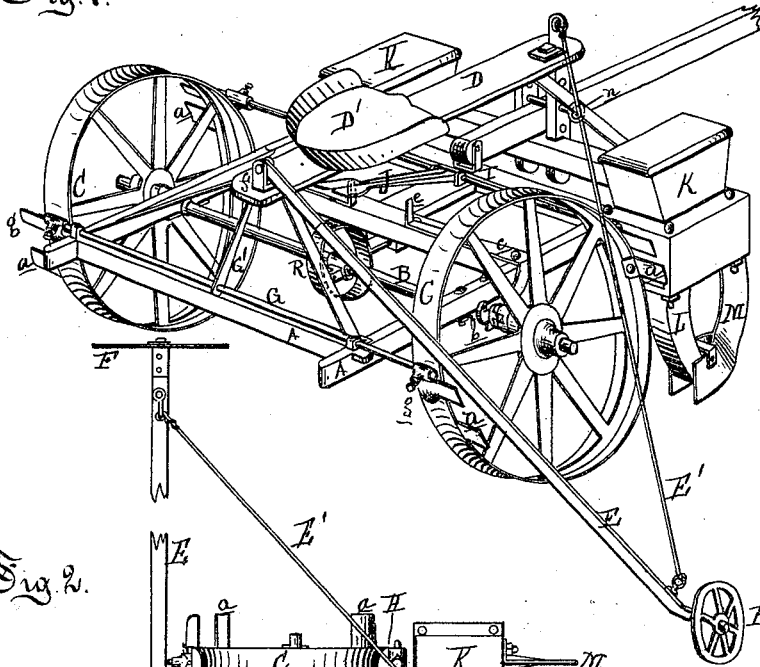
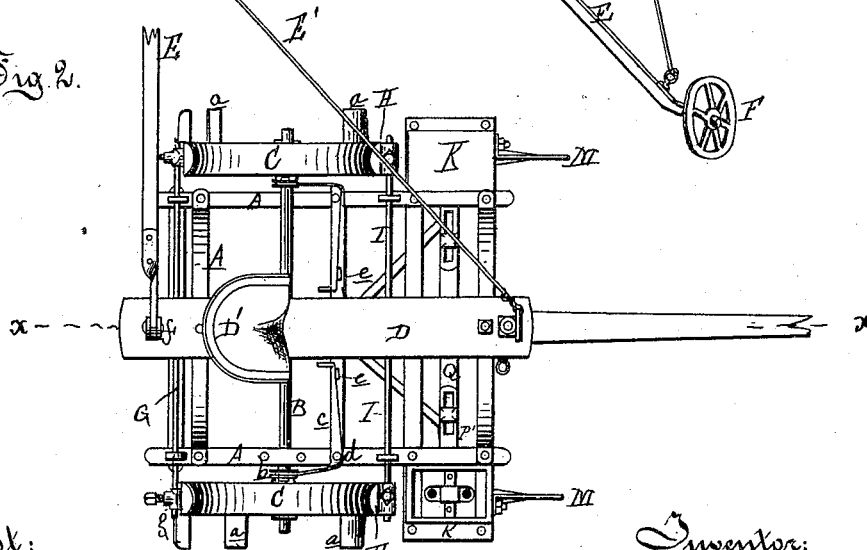

Fig. 2.



Attest:
Edward Parthel.
Wm. P. Spalding

Inventor:
A. M. Southard
By Atty
Wm. P. Spalding

A. M. SOUTHARD.
Corn-Planter.

No. 169,307.

Patented Oct. 26, 1875.

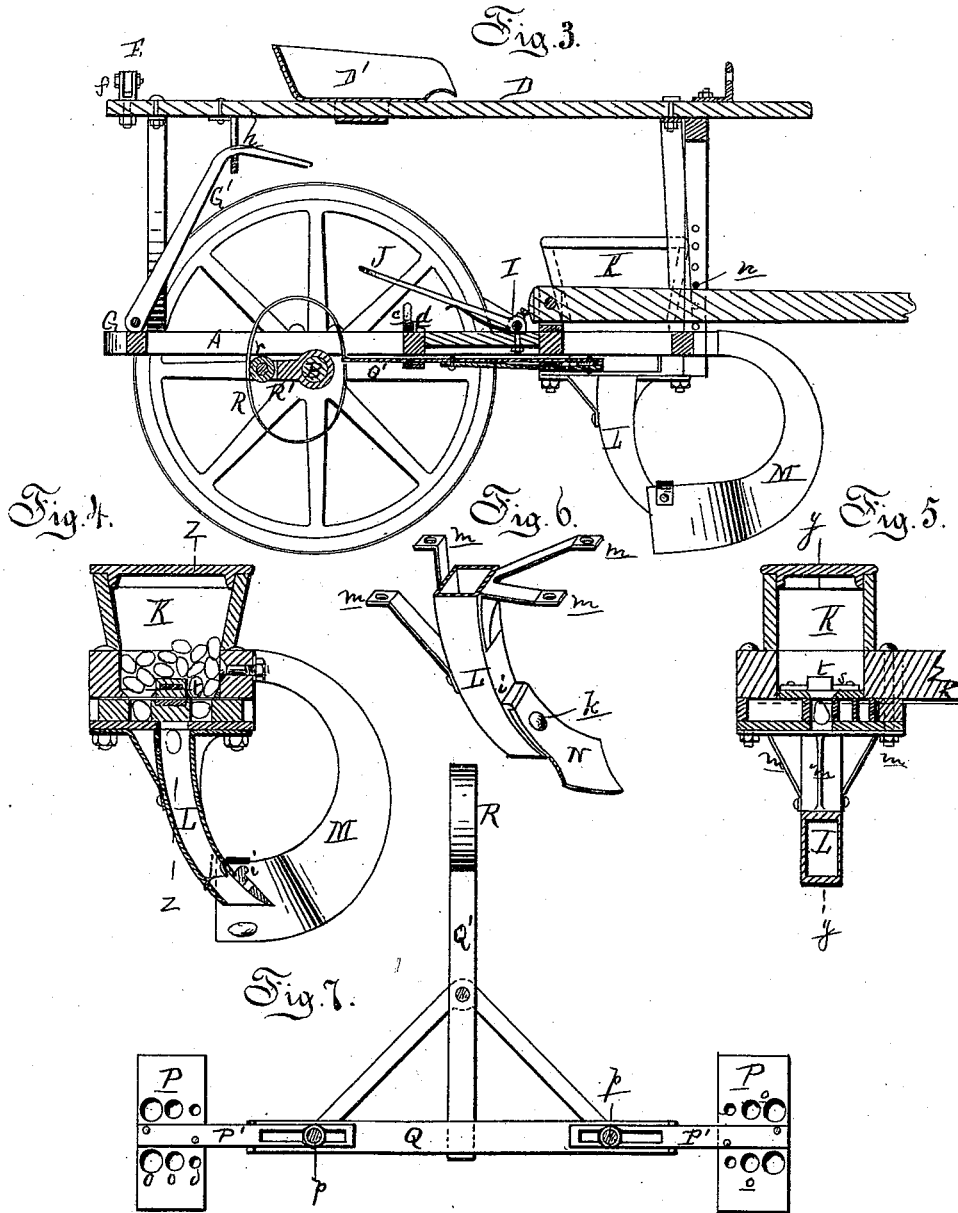

Attest:
Edmund Barthel.
Wm. P. Spalding

Inventor:
A. M. Southard
By Atty.
Thos. S. Sprague

UNITED STATES PATENT OFFICE.

ABRAHAM M. SOUTHARD, OF ELDORA, IOWA.

IMPROVEMENT IN CORN-PLANTERS.

Specification forming part of Letters Patent No. **169,307**, dated October 26, 1875; application filed April 27, 1875.

To all whom it may concern:

Be it known that I, ABRAHAM M. SOUTHARD, of Eldora, in the county of Hardin and State of Iowa, have invented an Improvement in Corn-Planters, of which the following is a specification:

The nature of my invention relates to certain improvements in check-row corn-planters, consisting, first, in the combination of the peculiar dropping mechanism; second, in the peculiar construction of the seed-spouts; third, in the peculiar construction, arrangement, and operation of the brakes employed to arrest the movement of the traction-wheels; and, fourth, in the peculiar manner of securing the guide-marker to the machine, whereby the same can be adjusted to either side of the said machine, without detaching it therefrom, by a half-axial rotation, all as more fully hereinafter explained.

Figure 1, Sheet 1, is a perspective view. Fig. 2 is a plan or top view. Fig. 3, Sheet 2, is a longitudinal section taken on the line $x x$ in Fig. 2. Fig. 4 is an enlarged vertical section taken longitudinally through a seed box and spout on the line $y y$ in Fig. 5, which is a transverse section at $z z$ in Fig. 4. Fig. 6 is a detached perspective view of a seed-spout with a plow attached. Fig. 7 is a detached plan view of the adjustable dropper-plates, and of the vibrating or reciprocating carrier-bar.

In the drawings, A represents the main frame, of wood, and rectangular in form. B is an axle, journaled through bearings under the frame, and upon each arm is sleeved a traction-wheel, C, having a broad concave rim, upon which two laterally-projecting marking-plates, a , are secured. Its hub is notched to receive a clutch-box, b , sliding on the axle, and actuated by a bent lever, c , pivoted at d to the top of the frame, at the side, the inner end being held in position by placing it in front of a pin or stud, e , when it is designed to have the axle rotate with the wheel; but when the axle is not to be rotated, both clutch-box levers are placed behind their studs. D is a horizontal elevated seat-rest, on which is arranged a sliding seat, D' , for the driver. E is a long light wooden bar, at whose outer end there is a bent iron arm, on which is mounted an iron guide-wheel, F, which, rolling upon

the ground, leaves a mark, to serve as a guide for the driver, who should keep the tongue of the implement directly over it in planting after the next turn. At its inner end there is an iron eyebolt, pivoted in a swivel, f , pivoted in the back end of the seat-rest. E' is a stay or guy rope, connecting the outer end of the bar E with an eyebolt on the front end of the seat-rest, to keep the said bar at a right angle with the seat-rest when extended either to the right or left.

In turning the machine, after unclutching the axle from the wheels the driver slides the seat back, then raises the bar E to a vertical position, and allows it to come forward and rest against his back. When the turn is completed, and the machine is moved laterally away, so as to bring the pole on the line previously described by the marking-wheel, the bar is to be lowered on the off side, or to field, to mark a fresh guide-line, giving the bar, however, a half axial rotation, so as to bring the marking-wheel to a vertical position when resting on the ground, after which the seat may be slid forward.

G is a rock-shaft, journaled across the rear end of the frame, with a scraper, g , secured to each end, which scraper is adapted to fit easily the rim of the traction-wheel and markers thereon, and is held pendant a short distance therefrom by a bent lever, G' , at the middle of the rock-shaft, whose arm rests on a hook, h , under the seat-rest. These scrapers remove earth adhering to the wheel-rims and marking-plates. H is a convex-ended brake, mounted at the end of a rock-shaft, I, extending from the front of each wheel-rim through boxes to the center of the frame, where the end of each rock-shaft is provided with a treadle, J, with a spring under it, to throw it up and keep the brake away from the wheel, except when the treadle is depressed by the driver's foot. The object of the brakes is to compel the machine to gain distance, by sliding the wheels along on the surface of the ground, to overcome the distance lost in turning, or from variation caused by uneven surfaces, and thus bring the marking-plates opposite the impressions at the side of each hill planted in the adjacent row.

The treadles are arranged side by side, within easy reach of the driver's foot, so that, with-

out moving from his seat, he can depress them separately or simultaneously. The seed-boxes *K K* are located at the front corners of the frame, and just below the bottom of each a cast-iron seed-spout, *L*, is sustained by braces *m*. Across the face of each spout, near the lower end, is cast a rib, *i*, with a hole above and another below it. *M* is a segment-shaped furrow-opener, open or forked at the bottom end to embrace the sides of the spout, to which it is secured by a hook, *j*, entering the upper hole, while the upper end is secured to the front girt of the frame by a bolt and nut.

For ordinary use this furrow-opener is found to be superior to the plow-shovel; but in fall planting it is advisable to use the latter; hence I fasten a shovel, *N*, to the spout by a bolt, *k*, through the lower hole, its upper end resting against the rib, which receives the thrust.

It will be seen, then, that either form of furrow-opener can be mounted on the seed-tubes, as occasion may require.

To regulate the depth of furrow the heel of the draft-tongue *O* passes between the two uprights which support the front end of the seat-rest, and is pivoted behind them to a clevis on the main frame. A pin, *n*, is passed through holes in said uprights above the tongue. The bottom plate of each seed-box has a longitudinal slot, and below is a dropper-plate, *P*, mounted on the under side of a shank, *P'*, extending inwardly at a right angle therewith, which shank has a slot at its inner end, which rests upon a bar, *Q*, having a T-shaped prolongation, *Q'*, to the rear, terminating in a vertical elliptic frame, *R*. The shanks *P'* are secured to the ends of the bar *Q* by nuts *p*, so as to form adjustable prolongations thereof. The shanks are let into the plates, so as to leave their surface flush. Through the plates are made three pairs of holes, *o*, each pair of different diameter, any pair being brought under the slot in the bottom plate by adjusting the shank on the bar *Q*, according to the size of kernel or quantity of seed to be planted. The dropper-plates and connections are reciprocated twice in each rotation of the axle by an arm, *R'*, fastened thereon adjustably by a set-screw, and having a roller, *r*, journaled in its extremity, which strikes each vertical wall of the elliptic frame *R*, and moves it forward

or backward as it sweeps around, the transverse diameter of the frame being a little more than the total length of the said arm. Across the middle of the slot in the bottom of the seed-box is a vertical bar, *s*, which passes through a block, *t*, of vulcanized india-rubber, which lies in contact with the face of the dropper-plate, and directly over the passage leading into the seed-spout, so that as one hole passes under said block to discharge the seed contained in it the other hole is exposed, and is being filled with seed.

In lieu of the revolving marker a wooden runner may be secured to the end of the marker-bar, which will be found preferable to the wheel, which is liable to clog in tenacious soils.

What I claim as my invention is—

1. The combination, with the seed-boxes *K*, of the dropper-plates *P*, having the holes *o*, and adjustably secured by their shanks *P'* to the T-shaped reciprocating bar *Q Q'*, substantially as described and shown.

2. The combination, with the seed-boxes, of the seed-spouts *L*, having the rib *i*, and a hole above and below said rib, adapted to receive a furrow-opener or a plow-shovel, substantially as described and shown.

3. In a seeding-machine, the combination, with the frame *A* and traction-wheels *C*, of the brakes *H*, secured to the ends of separate rock-shafts *I I*, journaled in the frame in front of said wheels, each rock-shaft extending from the front of one of the wheel-rims to the center of the frame, and provided with a foot-treadle, *J*, the said foot-treadles being arranged side by side, so that one or both of them can be depressed by one foot, substantially as shown.

4. The combination, with the elevated seat-frame *D*, of the bar *E*, wheel *F*, swivel *f*, and guy-rope *E'*, arranged as described, so that the said bar and wheel may be changed to the opposite side of the machine, without unloosing the guy-rope, by a half axial rotation, substantially as specified and shown.

ABRAHAM M. SOUTHARD.

Witnesses:

J. Q. PATTERSON,
JOSEPH EDGINGTON.