

W. O. STODDARD.

Machinery for Desiccating Eggs.

No. 169,311.

Patented Oct. 26, 1875.

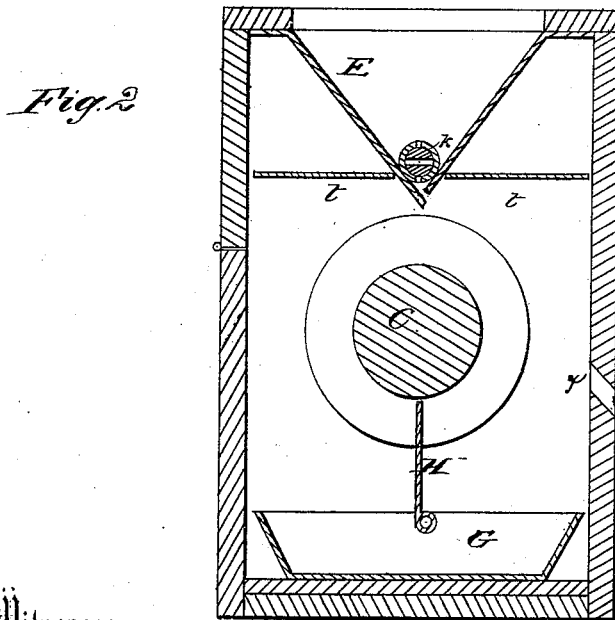
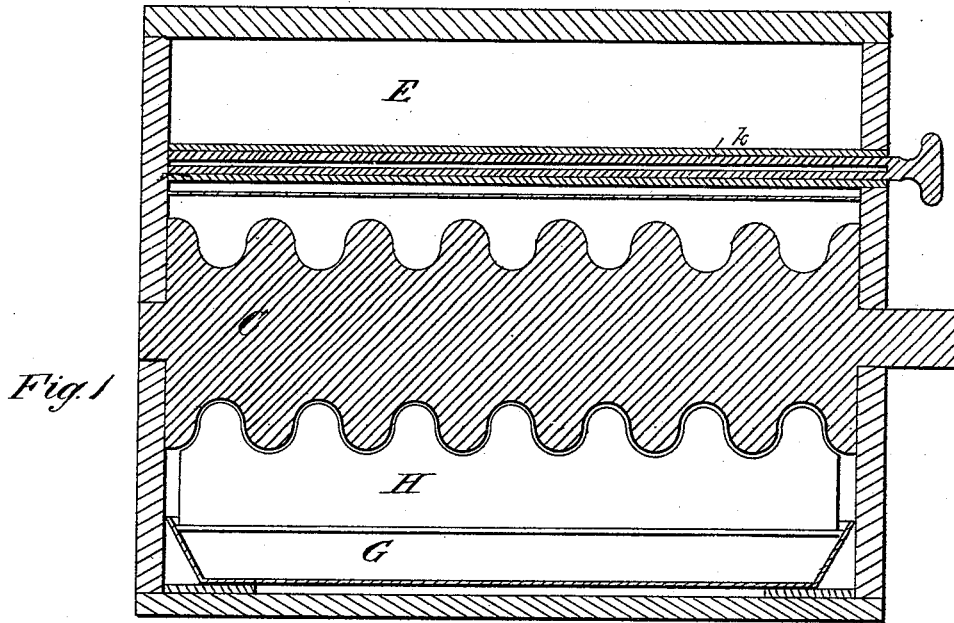

Witnesses  
*Geo. B. Connolly*  
*T. G. Smith*

Inventor  
*William Osborn Stoddard*  
*Connolly Bros*  
 Attorneys

W. O. STODDARD.  
Machinery for Desiccating Eggs.

Patented Oct. 26, 1875.

No. 169,311.

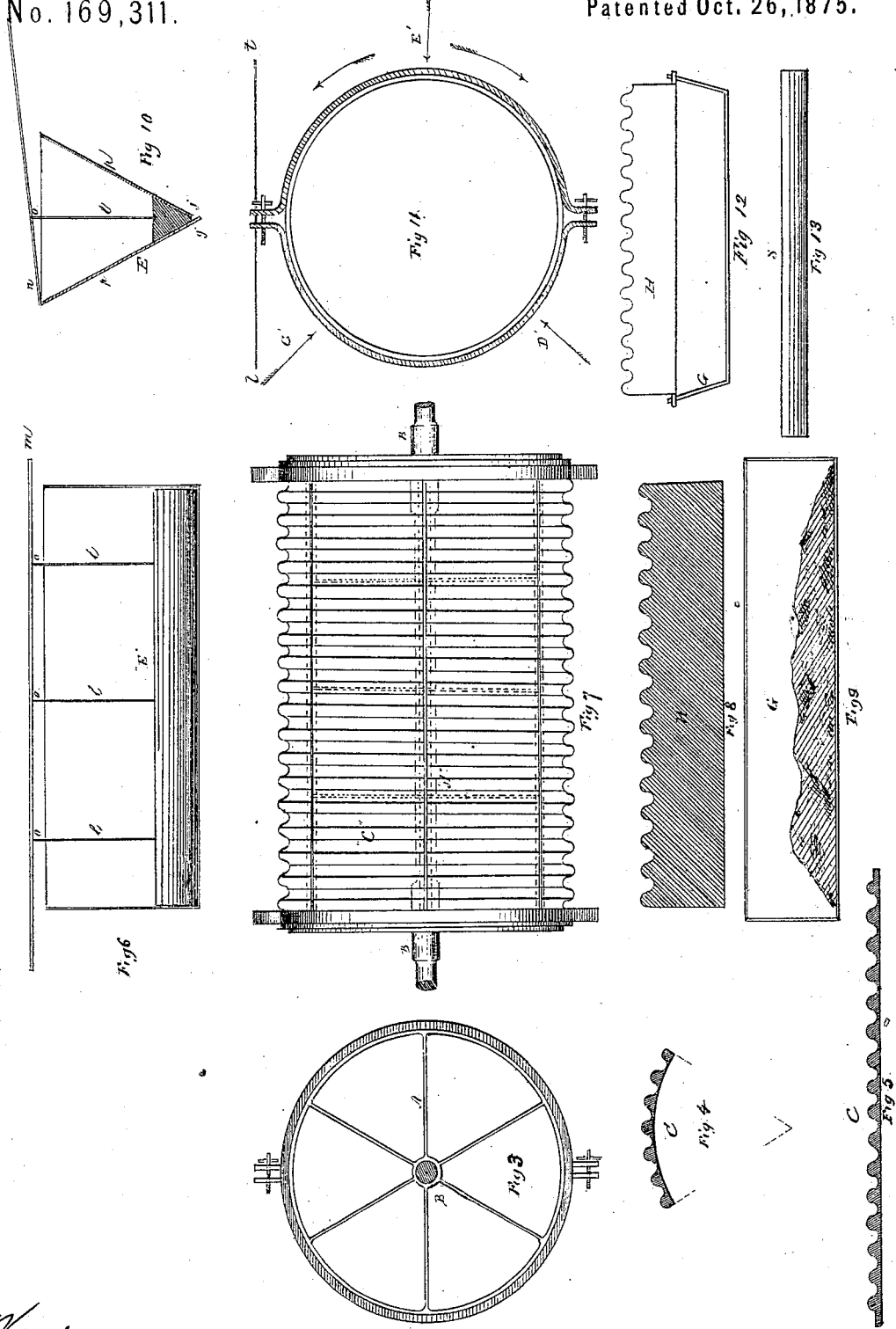

Witness,  
L. Andrew Jackson  
W. B. Whitney

Inventor,  
William O. Stoddard

# UNITED STATES PATENT OFFICE.

WILLIAM OSBORN STODDARD, OF NEW YORK, N. Y.

## IMPROVEMENT IN MACHINERY FOR DESICCATING EGGS.

Specification forming part of Letters Patent No. 169,311, dated October 26, 1875; application filed July 2, 1875.

*To all whom it may concern:*

Be it known that I, WILLIAM OSBORN STODDARD, of the city of New York, in the county of New York and State of New York, have invented a certain new and useful Improvement in Machinery for the Drying or Desiccating of Batter of Eggs; and I do hereby declare the following to be a full, clear, and exact description of the invention, such as will enable others skilled in the art to which it pertains to make and use it, reference being had to the accompanying drawings, which form part of this specification, in which—

Figure 1 is vertical longitudinal section, and Fig. 2 a vertical transverse section, of an apparatus constructed according to my improved plan. Fig. 3 is a vertical transverse section of the desiccating-cylinder. Figs. 4 and 5 are sections showing detachable corrugated-surface plates of desiccating-cylinder. Fig. 6 is a vertical longitudinal section through feeding-tank. Fig. 7 is a side view of the desiccating-cylinder. Fig. 8 is a side view of scraper. Fig. 9 is a longitudinal section through receiving-drawer. Fig. 10 is a vertical transverse section through feeding-tank. Fig. 11 is an end view of desiccating-cylinder. Fig. 12 is a vertical longitudinal section through receiving-drawer, showing scraper attached. Fig. 13 is a side view of stopper for feeding-tank.

The object of my invention is, by a rapid, simple, and economical process, to deprive such a viscid or glutinous material as, for instance, a batter made by beating together the yolks and whites of eggs of the watery particles therein contained, leaving the solid part thereof in a condensed form, suitable for preservation, transportation, and subsequent uses. This object is accomplished by means of the rotating cylinder, having either a plain or an indented or corrugated surface, upon which, while in rotation, the material to be dried or desiccated is fed from a feeding-tank, and subjected thereon to the distributing and drying effect of a forcible blast or blasts of air, applied at one or more points upon said surface of the cylinder, said blasts being supplied by any ordinary means, and as large a part of the surface of the revolving cylinder as may be convenient, being subjected at the

same time to the operation of said blast or blasts, the material so dried or desiccated being removed by a scraper, the removed material falling into and being received by a movable drawer.

The rotating cylinder required for the purposes of this invention—in case the size or weight thereof, or the nature of the material employed, renders it unadvisable or inconvenient to cast or mold or make the same in one mass or form, or permanent union of constituent pieces and parts, a cylinder of galvanized sheet-iron, with or without a frame of other material, being here noted as an instance of the latter mode of construction proposed by this invention—is composed of the frame or drum A on the axis or shaft B, said frame or drum being duly prepared by supports, tires, spokes, braces, and lateral bands or pieces, in the usual manner well known to mechanics, to sustain the weight of the surface intended to be placed thereon, for the purposes indicated, and of the said surface C, to be composed of one or more parts or pieces, the whole revolving upon the shaft or axis B, the revolution thereof being obtained by the ordinary means well known to mechanics, as a system of wheels and bands.

With reference particularly to the drying or desiccating of batter of eggs or albumen, the advantage of the revolving cylinder, as described, over the revolving plates or disks now in use, is that by the presentation of the unbroken surface of said cylinder is secured the full drying and distributing effect of the forcible blast or blasts of air, as C', D', and E', Fig. 11, the greater part whereof is now lost and wasted by escaping, without use, between the said disks or plates; and that, by thus securing the full effect of the forcible blast or blasts, as described, there is obtained a more rapid, complete, and economical removal of the watery particles of the batter of eggs or other material; and that said cylinder will receive and retain a greater number and thickness of successive layers of said material than will disks or plates, to the enhanced perfection of the product obtained, and the greater rapidity of its manufacture; and that by the use of said cylinder it is possible to employ a wide variety of available and inexpensive sub-

stances for the construction of its drying-surface, whether in one or more plate or plates, piece or pieces; and that the proposed method of the construction of said cylinder permits the ready and rapid replacement of any of the said surface-pieces, which may become broken or worn or otherwise unfit for use; and that the use of said cylinder permits the employment, at the same time, of more than one forcible blast of air, for the purposes indicated; and that such a form of construction secures a greater degree of strength and durability, in proportion to weight, than any other, with small liability to fracture of the drying-surface C; and also that the use of said cylinder permits the use, in combination therewith, of the feeding-tank E, which cannot be employed in connection with the revolving plates or disks now in use.

The adjustable feeding-tank E is of any ordinary and convenient form and design, and of any common material, as tin, suitable for the construction of such a cistern, for the purposes indicated, and the sides thereof, *p p*, at or near the bottom, should be inclined inward toward the discharging-mouth *f*, so as to insure a free exit for the batter of eggs or other material contained. The discharging-mouth *f* is provided with an elongated faucet, *k*, extending throughout the length or orifice thereof, or with the adjustable stopper *s*, and with the projecting lip *g*, the latter to receive and regulate and distribute more evenly the flow of the material upon the revolving cylinder below. In case hot-air blasts are employed in the process or manufacture indicated, the feeding-tank E, by whatever frame-work or support it may be kept in its required position for use, should be protected from the injurious effects of the heat by the non-conducting shield or fender *t t*, or by felting or doubling the sides of said tank, so as to render them approximately non-conducting.

The advantage obtained by the use of the feeding-tank, as described, especially over the dipping-trough, now in use, is that, while, by the latter, no more of the batter of eggs, or other material to be dried or desiccated, is taken up or retained upon the drying-surfaces employed, than may be so taken up or retained by capillary attraction or viscid adhesion, on the other hand, by means of the feeding-tank, the supply of said material may be kept continually up to the utmost limit of the distributing and drying power of the blasts of air, supplied for the purposes indicated, thereby greatly increasing the rapidity and economy of the process of manufacture.

Another marked disadvantage, arising from the use of the dipping-trough, in combination with surfaces upon which blasts of heated air are employed, is that, said surfaces becoming heated in work, they unduly heat and deteriorate the material, into which they are repeatedly dipped, and this disadvantage is manifestly avoided by the use of the feeding-tank, as described.

Fig. 12 gives a view of the sliding drawer G by itself, with the scraper H, the latter, when in use, being lightly pressed against the prepared material adhering to the surface C of the revolving cylinder A. The use of the sliding drawer is simply to receive the product scraped into it for convenient removal, and requires no special explanation.

Figs. 4 and 5 give separate views of one of the movable plates or pieces—in this instance corrugated—such as may be used for the formation of the surface of the revolving cylinder A, for the purposes indicated. The advantage to be obtained from the formation of the surface of a cylinder, such as herein described, and for the purposes indicated, of detachable pieces or plates of the substance selected for the construction of such a surface, is that, by this means, said surface may be the more readily cleansed, repaired, or renewed, in part or in whole, and that thereby it is made possible to employ a great variety of suitable and available substances, as fire-brick, seasoned wood, artificial stone of certain kinds, and other cheap, and yet otherwise unavailable, substances or material.

Fig. 13 gives a view of an adjustable stopper or regulator, *s*, applicable to the discharging-mouth *f*. In this figure, *s* is the stopper, of wood or other suitable material, shaped to fit the discharging-mouth *f* of the feeding-tank on the inside, and is connected by the adjusting-rods *l l l* at proper distances from each other, with the lifting-bar *m*, by which, by means of the lever *n*, or other common device, it is to be raised or lowered to increase or diminish the flow of the batter of eggs, or other material, through the discharging-mouth *f*. The adjusting-rods *l l l* pass through the sockets *o o o* of the lifting-bar *m* on properly-fitted screw-threads, which are provided with ordinary thumb plates or pieces, for the purpose of working said rods up and down, as may be required, and so adjusting the stopper or regulator *s*, throughout its length, to the lifting-bar *m*, that thereby the flow of the batter of eggs, through the discharging-mouth *f*, may be better controlled. It is necessary, by means of such a stopper, or of the elongated faucet hereinbefore mentioned, or otherwise, to be able to prevent a too rapid flow of the batter of eggs, or other material, contained in the feeding-tank, for the purposes indicated, and on the other hand to insure as rapid a flow as may be found consistent with successful manufacture.

It will be understood that, although I have referred to a revolving cylinder for receiving the material to be desiccated, I do not limit myself to any specific geometric form, but reserve the privilege of substituting for a cylinder any equivalent body of whatever shape desired.

I claim as my invention—

1. In an apparatus for desiccating eggs through the agency of forcible drying-blasts applied to the batter, while the latter is

spread upon a rapidly-moving surface, a rotary cylinder to receive and hold said batter during the process of desiccation, and in contact with the air-blasts, substantially as described.

2. The rotary desiccating-cylinder, in combination with the blast-conduits *x*, substantially as specified, for conducting the blast to and against the periphery of said cylinder, substantially as shown and described.

3. The combination, with a revolving cylinder for the reception and desiccation of batter of eggs, of a supply-tank, provided with a faucet or valve to regulate the flow of the batter, substantially as described.

4. The cylinder of an egg-desiccating apparatus, having its shell formed of detachable plates or sections, substantially as specified.

5. The combination of the supply-tank *E*, faucet or valve *k*, rotary desiccating-cylinder *C*, scraper *H*, and receiver *G*, substantially as shown and described.

In testimony that I claim the foregoing I have hereunto set my hand this 28th day of June, 1875.

WILLIAM OSBORN STODDARD.

Witnesses:

L. ANDREWS JACKSON,  
W. M. WHITNEY.