

T. W. GODWIN.  
STEAM-BOILER.

No. 169,434.

Patented Nov. 2, 1875.

*Fig. 1*

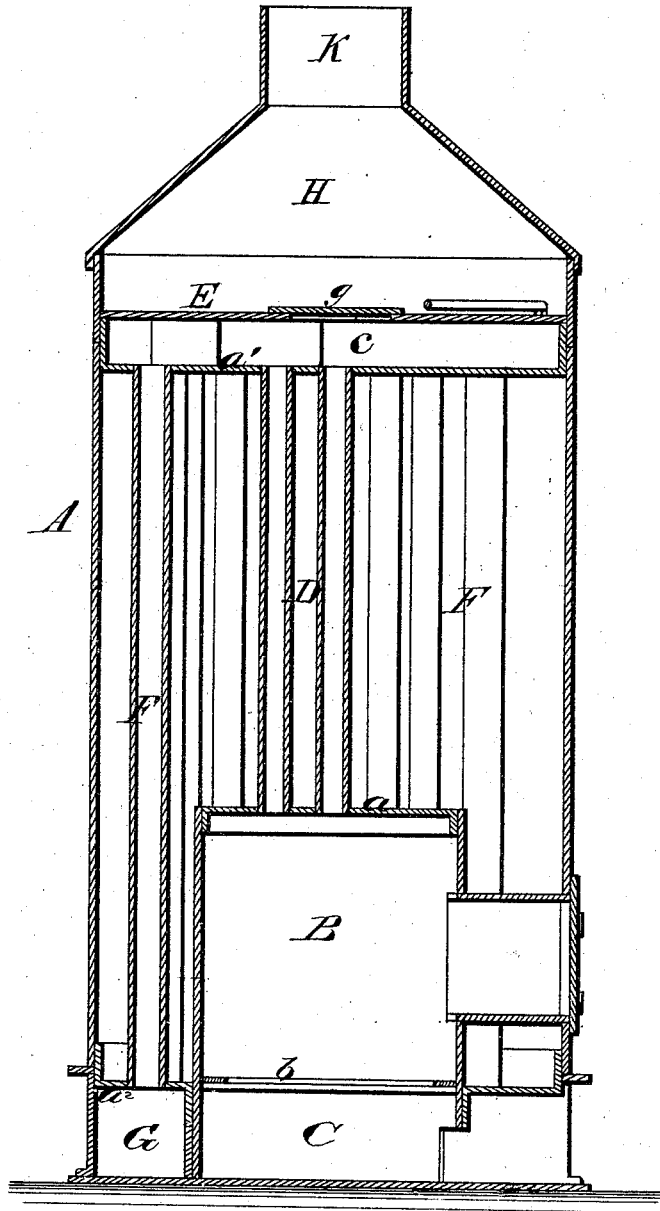

WITNESSES

*Robert Covrill,*  
*Walter B. Masi*

INVENTOR,

*Thomas W. Godwin,*  
*Chipman Hasome & Co.*  
ATTORNEYS.

T. W. GODWIN.  
STEAM-BOILER.

No. 169,434.

Patented Nov. 2, 1875.

*Fig. 2*

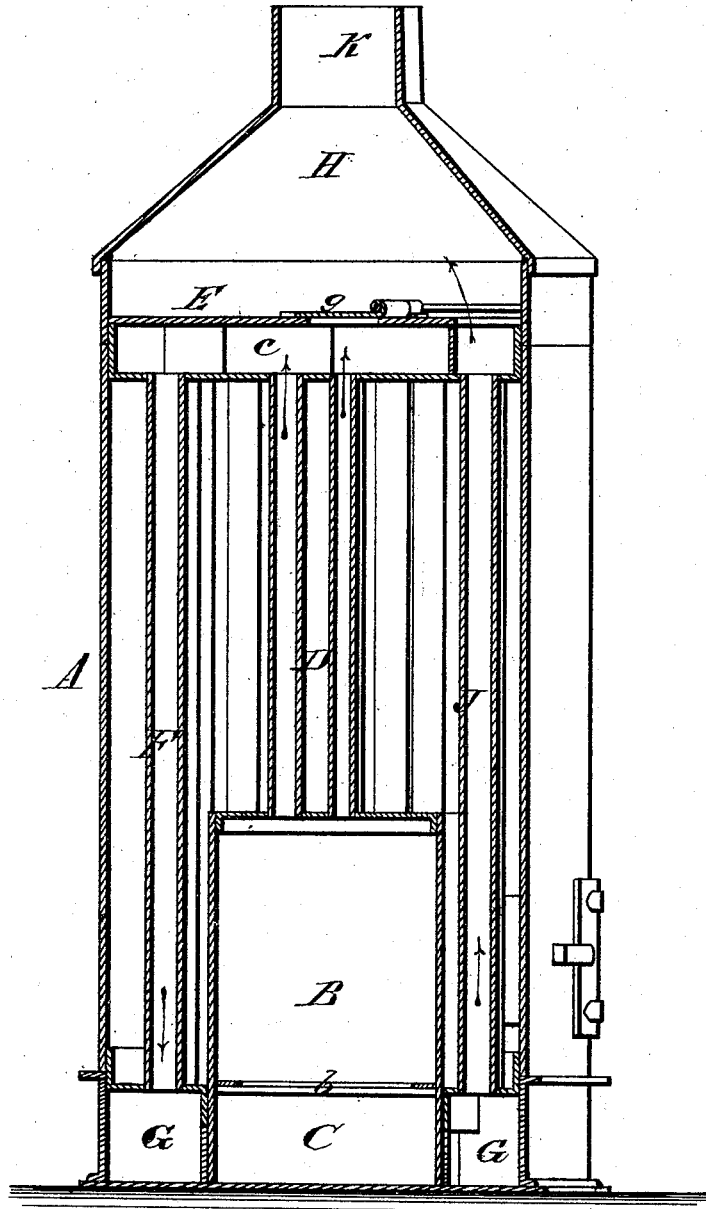

WITNESSES  
*Robert Everett,*  
*Walter Q. Masi*

INVENTOR,  
*Thomas W. Godwin.*  
*Chipman Hosmer & Co.*  
ATTORNEYS

T. W. GODWIN.  
STEAM-BOILER.

No. 169,434.

Patented Nov. 2, 1875.

*Fig. 3*

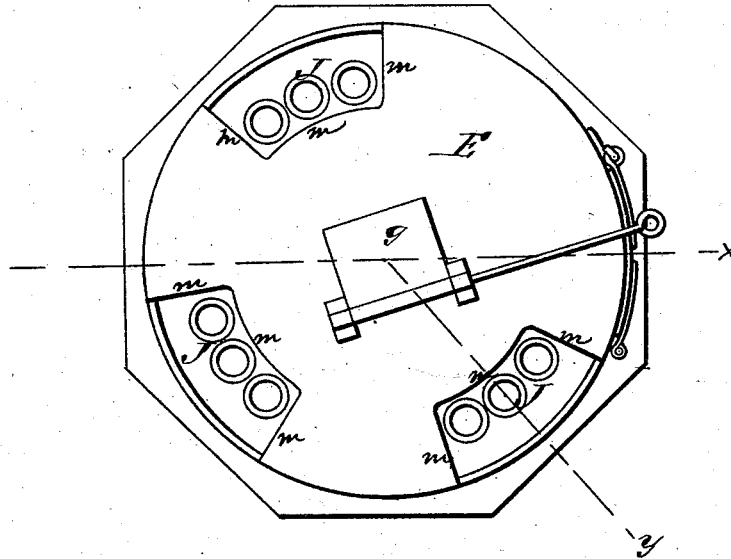

*Fig. 4*

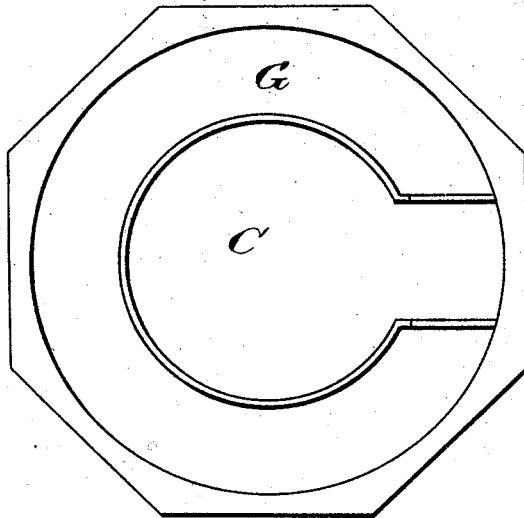

WITNESSES

*Robert Smith*  
*Walter C. Mallie*

INVENTOR,

*Thomas W. Godwin.*  
*Chipman Hooper & Co.*

ATTORNEYS.

# UNITED STATES PATENT OFFICE.

THOMAS W. GODWIN, OF NORFOLK, VIRGINIA.

## IMPROVEMENT IN STEAM-BOILERS.

Specification forming part of Letters Patent No. 169,434, dated November 2, 1875; application filed October 21, 1875.

*To all whom it may concern:*

Be it known that I, THOMAS W. GODWIN, of Norfolk, in the county of Norfolk and State of Virginia, have invented a new and valuable Improvement in Steam-Boilers; and I do hereby declare that the following is a full, clear, and exact description of the construction and operation of the same, reference being had to the annexed drawings, making a part of this specification, and to the letters and figures of reference marked thereon.

Figures 1 and 2 of the drawings are representations of vertical sections of my steam-boiler improvement, and Fig. 3 is a plan view of the same. Fig. 4 is a plan view of the water-chamber.

This invention has relation to upright steam-boilers, which are especially designed for use in cotton factories and gins, for the purpose of guarding against fire from escaping sparks; and the nature of my invention consists in an upright boiler having a spark-trap at its base, in combination with a recessed cap having projecting flanges, which deflect the products of combustion, causing them to pass in a devious course downwardly through a series of vertical tubes into a spark-trap filled with water, which extinguishes the sparks, the products of combustion passing thence upwardly through a series of vertical tubes into a chamber, and thence through an eduction-pipe into the open air, as hereinafter more fully set forth.

In the annexed drawings, A designates the cylindrical shell or casing of my upright boiler, and  $a^1 a^2$  are the three flue-sheets. B designates the furnace-chamber, between which and the ash-pit C are the grate-bars  $b$ . From the furnace-chamber B the products of combustion ascend through a cluster of flues, D, into a chamber,  $e$ , which is formed by a casting, E, supported upon the flue-sheet  $a^1$ . E (see Fig. 3) is a recessed cap provided with flanges  $m$ , the lower edges of which rest on the top of the boiler. The products of combustion

pass upwardly from the furnace through the central tubes, and, when the damper  $g$  is closed, pass down through the vertical tubes included between the flanges into the spark-trap, filled with water, which extinguishes the sparks, the products of combustion passing thence upwardly through the tubes J, outside of the flanges of the cap, and thence through the pipe K into the open air. F designate flues, which conduct the products of combustion from the chamber  $e$  down into a water receptacle or trap, G, formed in the base of the boiler, outside of the ash-pit C. The tubes or flues F are secured to the flue-sheets  $a^1 a^2$ , and cause the sparks to dive down into water in the chamber G, where they are extinguished. From the chamber G the products of combustion ascend through tubes or flues J into a chamber, H, from which they are carried off through a pipe, K.

In practice I shall make an opening through the casting E, and provide it with a damper,  $g$ , which, when opened, will give a direct draft from the furnace to the stack. This damper will also allow me to regulate the draft of the furnace.

It will be seen from the above description that I not only utilize the heat by conducting the products of combustion three times through the water-space, but I also insure the extinguishment of all the sparks.

What I claim as new, and desire to secure by Letters Patent, is—

The recessed cap E, having projecting flanges  $m$  and damper  $g$ , in combination with the tubes D F J, spark-trap G, and chamber C, substantially as described, and for the purpose set forth.

In testimony that I claim the above I have hereunto subscribed my name in the presence of two witnesses.

THOS. W. GODWIN.

Witnesses:

WALTER C. MASI,  
BRYAN H. MORSE.