

W. F. FISHER & A. C. BROWN.

FLUTING-IRON.

No. 169,534.

Patented Nov. 2, 1875.

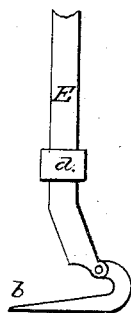
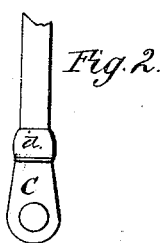
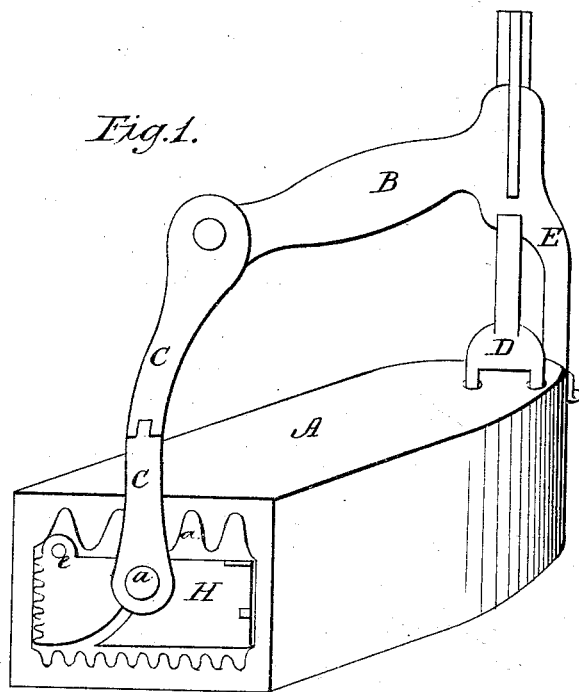

Attest:

John C. Holt
J. D. Williams

Inventors:

William F. Fisher,
Amos C. Brown

W. F. FISHER & A. C. BROWN.

FLUTING-IRON.

No. 169,534.

Patented Nov. 2, 1875.

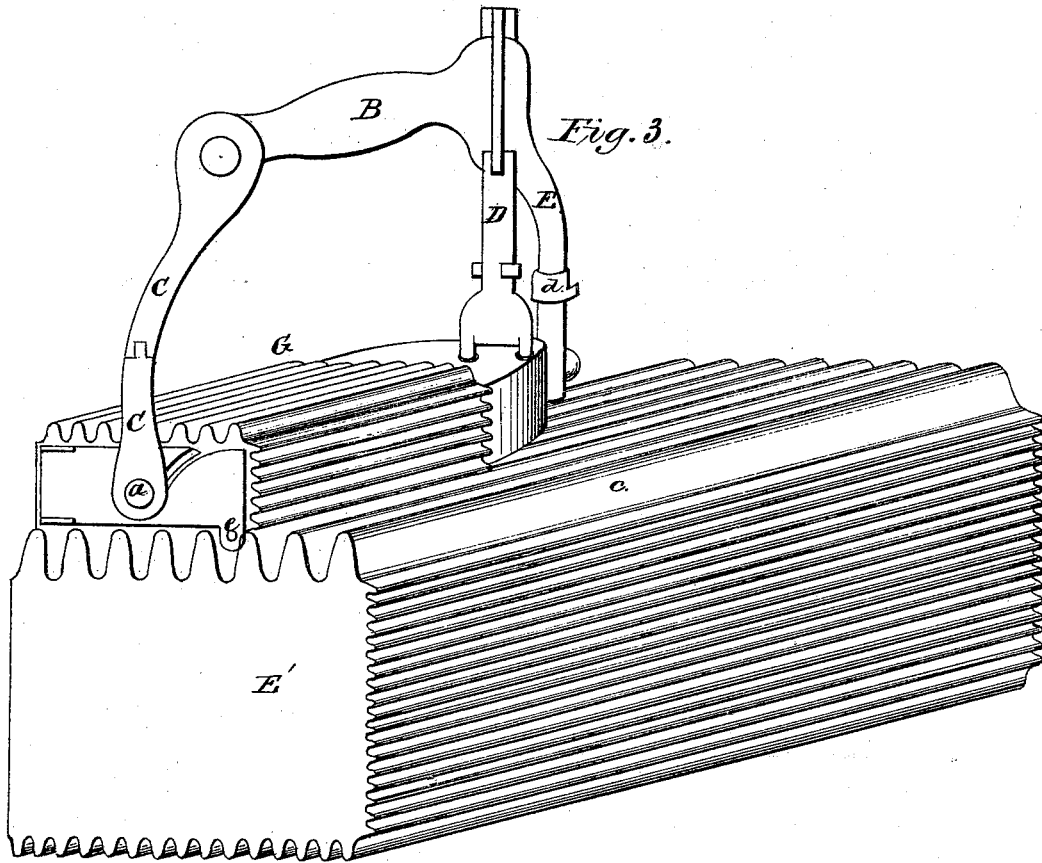

Attest:

John C. Holt
J. D. Williams

Inventors:

William F. Fisher,
Amos C. Brown

W. F. FISHER & A. C. BROWN.

FLUTING-IRON.

No. 169,534.

Patented Nov. 2, 1875.

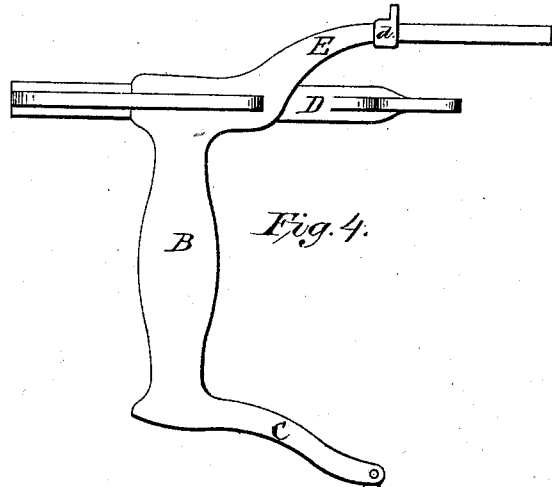

Fig. 4.

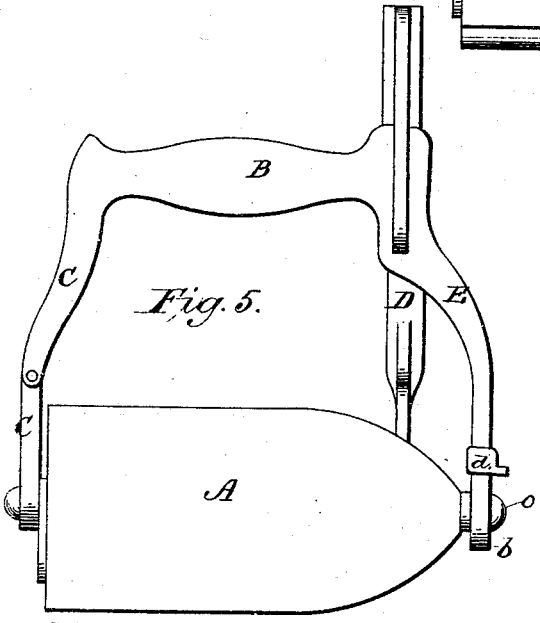
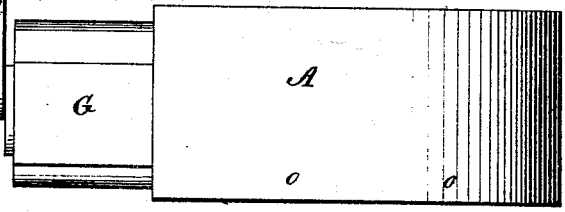

Fig. 5.

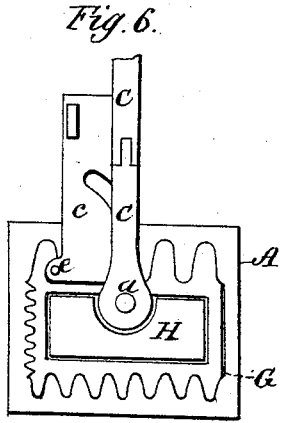

Fig. 6.

Attest:
John C. Holt
J. S. Williams

Inventors:
William F. Fisher,
Amos C. Brown

UNITED STATES PATENT OFFICE.

WILLIAM F. FISHER, OF BREMOND, AND AMOS C. BROWN, OF HOUSTON,
TEXAS.

IMPROVEMENT IN FLUTING-IRONS.

Specification forming part of Letters Patent No. **169,534**, dated November 2, 1875; application filed
February 27, 1875.

To all whom it may concern:

Be it known that we, W. F. FISHER, of Bremond, in the county of Robertson, and A. C. BROWN, of Houston, in the county of Harris, and State of Texas, have invented a new and Improved Smoothing and Fluting Iron; and we do hereby declare that the following is a full, clear, and exact description of the same, reference being had to the accompanying drawing, forming a part of this specification.

Our invention consists in a hollow smoothing and glossing iron in which a fluting-iron is inserted, the latter being also hollow to adapt it to receive a heating-block, so that the several parts may be, so to speak, "nested," thus economizing space, material, and the cost of manufacture, and combining several implements in one.

Referring to the drawing, A represents the hollow smoothing-iron, which is provided with a handle, B, having arms C E, by which it is pivoted to the ends of the iron, as shown. D is a forked bar, which slides through a slot in the handle B, and whose function is to lock the iron A and said handle rigidly together. As shown in Fig. 1, they are so locked that the broader side of the iron can be used, and in Fig. 5 the narrower. The locking is effected by the prongs of the fork entering sockets in the iron, as shown. The fluting-iron G is fitted within the smoothing-iron A, and is in turn made hollow, to receive the heating-block H. A plate, c, is pivoted to the fluting-iron at e to retain the heating-iron in place while the fluting or smoothing iron is being used. In Fig. 6 it is shown raised, to allow the heating-block H to be withdrawn and another substituted, the heat being supplied by a series of such blocks. The plate c has a curved open

slot to receive the pivot-pin a of handle B. The arm C of handle B is jointed, as shown, to adapt the latter to be tilted backward, and made available in withdrawing iron G from iron A, as in Fig. 4. The front arm E must first be disengaged from the front pivot-pin o. To this end we provide it with a hinged and curved piece, b, whose free end is secured by a sliding ring, d. When the handle-arm E has been thus detached from pivot-pin o, and the fluting-iron drawn out, said arm may be similarly connected to the front end of iron G, so that the latter may be used on a corrugated block, E', in the usual way, the two G E' having correspondingly-fluted sides, as in Fig. 3.

By the construction and arrangement above described the handle B and heating-block H serve for both irons A and G, and the ordinary operations of smoothing and fluting may be performed by aid of this implement without the necessity of the operator employing or possessing separate irons for the purpose.

What we claim is—

1. The combination of handle B, locking device D, and an iron for smoothing or fluting, said handle being pivoted in the manner shown and described.
2. The hollow irons A and G, having corresponding inner and outer surfaces, respectively, combined as shown and described.
3. The combination of hinged lock-piece b and slide d with the handle B C E and iron A, as shown and described.

WILLIAM F. FISHER.
AMOS C. BROWN.

Witnesses:

JOHN O. HOLT,
J. S. WILLIAMS.