

P. LUGENBELL.
HAND-TRUCK.

No. 169,559.

Patented Nov. 2, 1875.

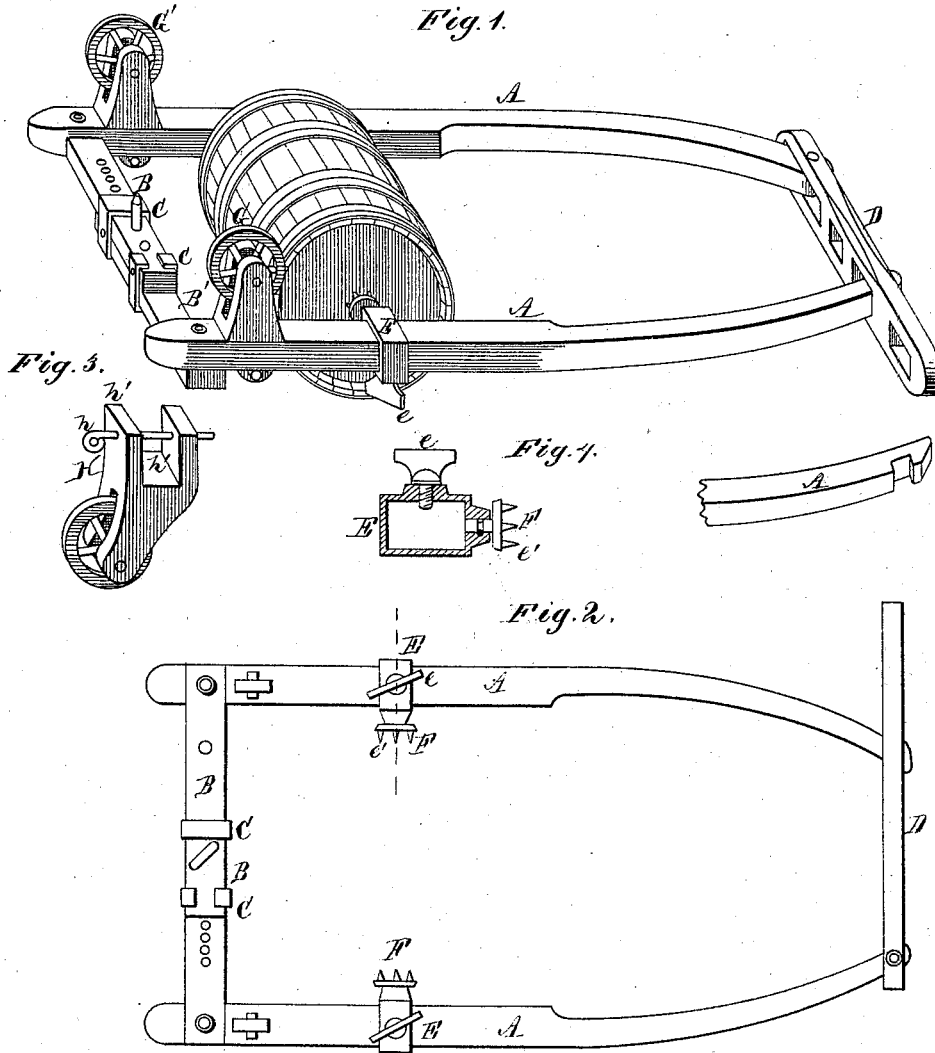

WITNESSES

Henry N. Miller
C. R. Everett

By

INVENTOR

Peter Lugenberg
Alexander Sutherland

Attorney

UNITED STATES PATENT OFFICE

PETER LUGENBELL, OF GREENSBURG, INDIANA.

IMPROVEMENT IN HAND-TRUCKS.

Specification forming part of Letters Patent No. 169,559, dated November 2, 1875; application filed April 13, 1875.

To all whom it may concern:

Be it known that I, PETER LUGENBELL, of Greensburg, in the county of Decatur and in the State of Indiana, have invented certain new and useful Improvements in Machines for Handling Boxes and Barrels; and do hereby declare that the following is a full, clear, and exact description thereof, reference being had to the accompanying drawings, and to the letters of reference marked thereon, making a part of this specification.

This invention relates to a new and improved truck for handling boxes, barrels, and the like, which can be readily adjusted to receive boxes or barrels of various sizes, as fully hereinafter set forth.

The invention consists of two shafts united at their ends by adjustable cross-pieces, each being provided with a movable sleeve carrying a pointed clutch, capable of being fastened in the heads of the barrel or sides of the box, in order to secure the same between said arms or shafts. The shafts are provided with wheels near their rear ends, upon which they may be drawn when used in handling boxes, said wheels being turned up when the apparatus is used for rolling barrels, the barrel being rolled directly on the ground. The adjustable cross-piece at the rear is also provided with a detachable wheel, which may be secured to the apparatus where it is desirable to draw the same over a narrow gangway or plank, after the manner of a wheelbarrow.

In the drawings, Figure 1 represents a perspective view of my improved apparatus, showing a barrel in position between the clutches. Fig. 2 represents a view looking down upon the apparatus; Fig. 3, a detached view of the central wheel; and Fig. 4, a detached sectional view of one of the sleeves and clutches, by means of which the box or barrel is secured to the truck.

The letters A A represent the shafts or arms, united at their rear ends by means of an adjustable cross-piece, consisting of two beams, B and B', fastened to the arms A, and secured to each other by means of the collars C C, one attached to each beam at its end,

and sliding loosely on the opposite beam, in order that the arms or shafts A A may be brought together or separated, to adjust the apparatus for boxes or barrels of different sizes. The front ends of the shafts are united by means of a slotted cross-beam, D, which is permanently fastened to one of the shafts, the other end being adapted to fit and be secured in the slots for the purpose of adjustment. E E represent two sleeves fitting loosely upon the shafts A A, so as to slide upon the same, and provided with set-screws e e, by which they may be secured at any desired point. To said sleeves are pivoted the clutches F F, consisting each of a metallic disk with a series of pointed studs or projections, e' e', on its face, which enter the ends of the box or barrel, and secure it between the shafts or arms A A. G G represent two wheels rigidly attached to the shafts A A, and H a detachable wheel, which may be secured to the beams B B by means of a pin, h, passing through the slotted carrier h' when it is desired to draw the truck over a narrow gangway, after the manner of a wheelbarrow. The beams B B' are provided with a series of apertures, b b', through which the pin I may be passed for the purpose of fastening them together when properly adjusted.

The operation of the apparatus will be readily understood from the above description. When the truck is to be used for handling boxes, the wheels are turned down, so that it will travel upon the same. When used for trundling a barrel, however, said wheels are turned up, as shown in Fig. 1, allowing the barrel to be rolled directly upon the ground.

Having described my invention, what I claim, and desire to secure by Letters Patent, is—

1. The combination of the shafts A A, adjustable beams B B', and adjustable clutches F F, substantially as and for the purposes set forth.
2. The combination of the arms or shafts A A, adjustable beams B B', clutches F, and slotted cross-beam D, substantially as set forth.
3. The combination of the shafts A A, se-

cured together by adjustable cross-beams, the clutches F F, and wheels G G, as and for the purposes specified.

4. The combination of the arms or shafts A A, secured together by means of adjustable cross-beams, clutches F F, and detachable center wheel H, substantially as specified.

In testimony that I claim the foregoing I have hereunto set my hand this 16th day of March, 1875.

PETER LUGENBELL.

Witnesses:

J. L. WOODEN,
WILLIAM T. MARTIN.