

C. BEHLEN.

RUNNING-GEAR FOR VEHICLES.

No. 169,616.

Patented Nov. 9, 1875.

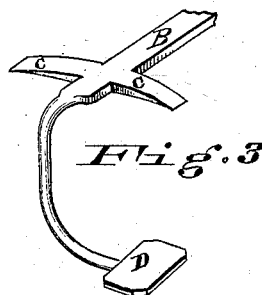
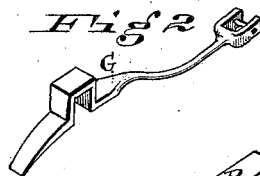
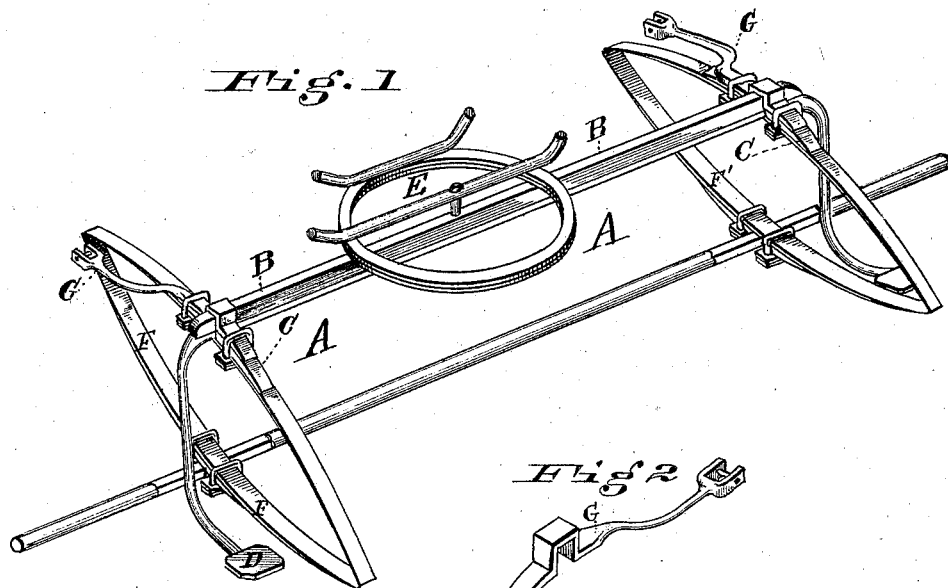

*Attest*

*J. P. Kennedy*

*O. A. Dressel*

*Inventor*

*Charles Behlen*

*per Wm. Hubbell Fisher,*

*his Atty in fact.*

# UNITED STATES PATENT OFFICE.

CHARLES BEHLEN, OF CINCINNATI, OHIO.

## IMPROVEMENT IN RUNNING-GEARS FOR VEHICLES.

Specification forming part of Letters Patent No. **169,616**, dated November 9, 1875; application filed May 1, 1875.

*To all whom it may concern:*

Be it known that I, CHARLES BEHLEN, a resident of the city of Cincinnati and State of Ohio, have invented certain new and useful Improvements in Road-Vehicles, of which the following is a specification:

My invention consists in forming on each end of the supporting-bar of the fifth-wheel of vehicles a step, thereby obviating the necessity of using bolts or other means of attachment, requisite when the step is constructed in a separate piece. It also adds to the finish and appearance of the vehicle.

In the accompanying drawing, forming part of this specification, Figure 1 represents, in perspective, the frame of the running-gears of a road-vehicle embodying my improvements. Fig. 2 represents the shaft-coupling. Fig. 3 represents a portion of the supporting-bar, showing my improvements in detail.

A represents the frame. B is the supporting-bar of the fifth-wheel, having formed on its ends a cross-piece or web, C, which rests on top of the spring. D is the step, for the

purpose of getting into and out of the vehicle, made in one piece with the supporting-bar and web. E is the fifth-wheel, of the usual style. F F' are the springs, on top of which rest the webs C of the supporting-bar B. G is the shaft-coupling, fastened on top of supporting-bar B by any suitable means. From its novel position the draft is downward, and by reason thereof obviates any trouble in the action of the fifth-wheel which would be likely to occur when the coupling is attached below the bar and the draft is upward.

What I claim as new, and desire to secure by Letters Patent, is—

In a vehicle, the supporting-bar of the fifth-wheel, terminating in steps D, forming integral parts thereof, substantially as and for the purpose specified.

CH. BEHLEN.

Attest:

ADAM SCHRAFFENBERGER.  
D. P. KENNEDY.