

W. H. BROCK.

APPARATUS FOR MAKING PAPER-VESSELS.

No. 169,619.

Patented Nov. 9, 1875.

Fig 1.

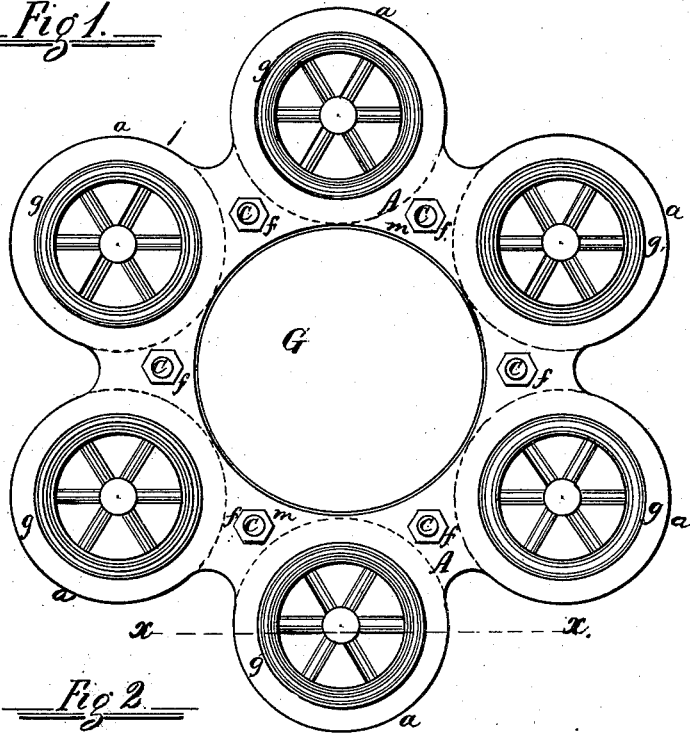
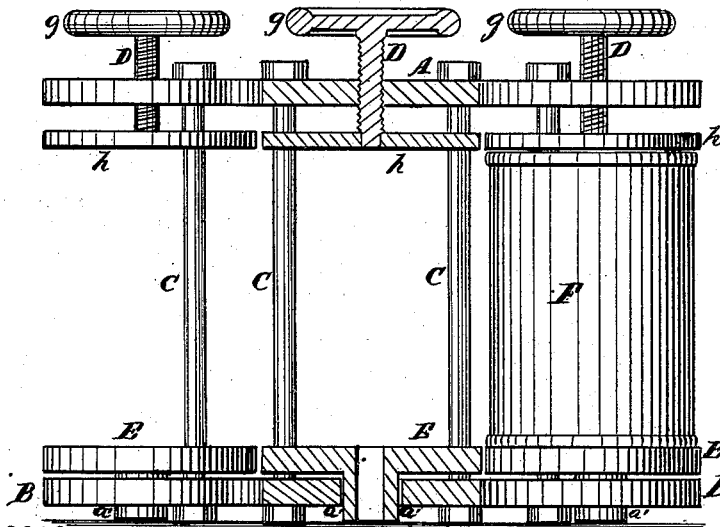

Fig 2.



Witnesses.

W. M. Edwards
W. H. Matthaei

Inventor.
W. H. Brock
per James W. Whitney
Att'y

UNITED STATES PATENT OFFICE.

WILLIAM H. BROCK, OF HUNTER'S POINT, ASSIGNOR TO JABEZ A. BOSTWICK, OF NEW YORK, N. Y.

IMPROVEMENT IN APPARATUS FOR MAKING PAPER VESSELS.

Specification forming part of Letters Patent No. 169,619, dated November 9, 1875; application filed January 7, 1875.

CASE B.

To all whom it may concern:

Be it known that I, WILLIAM H. BROCK, of Hunter's Point, in the county of Queens and State of New York, have invented certain Improvements in Apparatus for Making Paper Vessels, of which the following is a specification:

This invention is designed to facilitate the manufacture of that class of vessels in which heads of wood or other material are cemented in a cylindrical body of paper or paper material.

The invention consists in a novel combination of an annular frame, carrying compressing-screws, with platens, hand-wheels, and swiveled base-plates, the whole arranged for operation in such wise as to provide an efficient and easily-manipulated apparatus for holding the heads under pressure in the cylindrical bodies during the setting or fixing of the cement, whereby the heads are attached and sealed to the bodies; the apparatus as thus constructed enabling the manufacture of paper vessels of superior quality to be cheaply made on a large or extended scale.

The invention further comprises a novel combination of a system of such presses with an annular frame capable of rotary movement upon a suitable support, whereby a large number of the vessels may be conveniently treated, according to my method, at one and the same time.

Figure 1 is a plan view, and Fig. 2 a vertical sectional view taken in the line *x* of Fig. 1, of the mechanism forming part of my invention.

Having reference to the drawings, A and B are two annular plates, having semicircular projections *a* from their circumferences, and placed in parallel planes, these two plates being arranged at a suitable distance apart, and connected by rigid rods C, furnished at their extremities with screw-threads, on which are screwed the nuts *f*, which bind the whole firmly together to form the frame of the apparatus. At the axial point of the semicircular projections *a* of the plate A are provided internally-threaded openings or nuts, through which work

the screws D. These screws are provided at their outermost ends with hand-wheels *g*, for turning them, and at their innermost ends with swiveled platens *h*, of circular form, the swiveling of the platens upon the extremities of the screws permitting an axial movement of each platen, the purpose of which will be hereinafter fully set forth. E are circular bed-pieces, formed with central pivots or axles, that work in sockets *a'*, formed at the axes of the semicircular projections *a* of the plate B, in the axial lines of the screws D, the said bed-pieces E being, therefore, capable of an axial or rotatory movement coincident with or corresponding to that of the platens *h*.

In the operation of the apparatus each vessel, (formed with a paper body and a head or heads of wood or other material,) having the head or heads inserted into the ends of the paper body, with suitable cement provided between the two, is placed between a platen, *h*, and its coincident bed-plate E, whereupon the screw D, actuating the platen, is turned to force the platen inward, thereby compressing the vessel endwise between the platen and bed-piece, as indicated at F in Fig. 2, and forcing the heads home to their places, holds them by a fixed and positive pressure until the cementing material has had time to set or solidify. By this means a tighter and more impervious joint between the head of the vessel and the body thereof is secured than is possible of attainment by the usual method of simply forcing the heads snugly to their places by a more or less irregular, and always a temporary, pressure. In providing this positive and continued pressure to hold the heads in proper position with reference to the body of the vessel until the setting of the cement, very decided advantages are realized by the mechanism which constitutes a part of my herein-described invention.

The platen and bed-piece, working in connection with each screw, being swiveled, and thereby capable of an independent rotatory movement, one or both of them may remain either fixed against such rotary motion, independent of the turning movement of the screw,

or the same, with the vessel clasped between, may turn independent of the screw. By this means the screw may be operated in compressing the heads to their places, and holding them there, without exerting any friction upon the said heads, either or both, which, by inducing torsion of the paper body of the vessel, would destroy the integrity thereof, and render the vessel useless. Furthermore, the several screws, with their respective adjuncts, being arranged in a series or system around and within the frame, formed as herein previously described, and the central openings *m* of the plates A B of said frame permitting it to be placed upon a suitable pivot or fixed shaft, (indicated at G in Fig. 1,) which shaft may be

either vertical or horizontal, the entire apparatus may be readily turned around to permit the introduction and compression of a large number of the vessels in succession, and their removal in like manner, with great ease and convenience.

What I claim as my invention is—

The annular frame carrying the screws, the platens, hand-wheels, and swiveled base-plates, the whole combined and arranged for operation substantially as and for the purpose specified.

WILLIAM H. BROCK.

Witnesses:

W. W. JOHNSON,
A. M. EDWARD.