

J. F. GOODRIDGE.  
SLEEPING-CAR.

No. 169,633.

Patented Nov. 9, 1875.

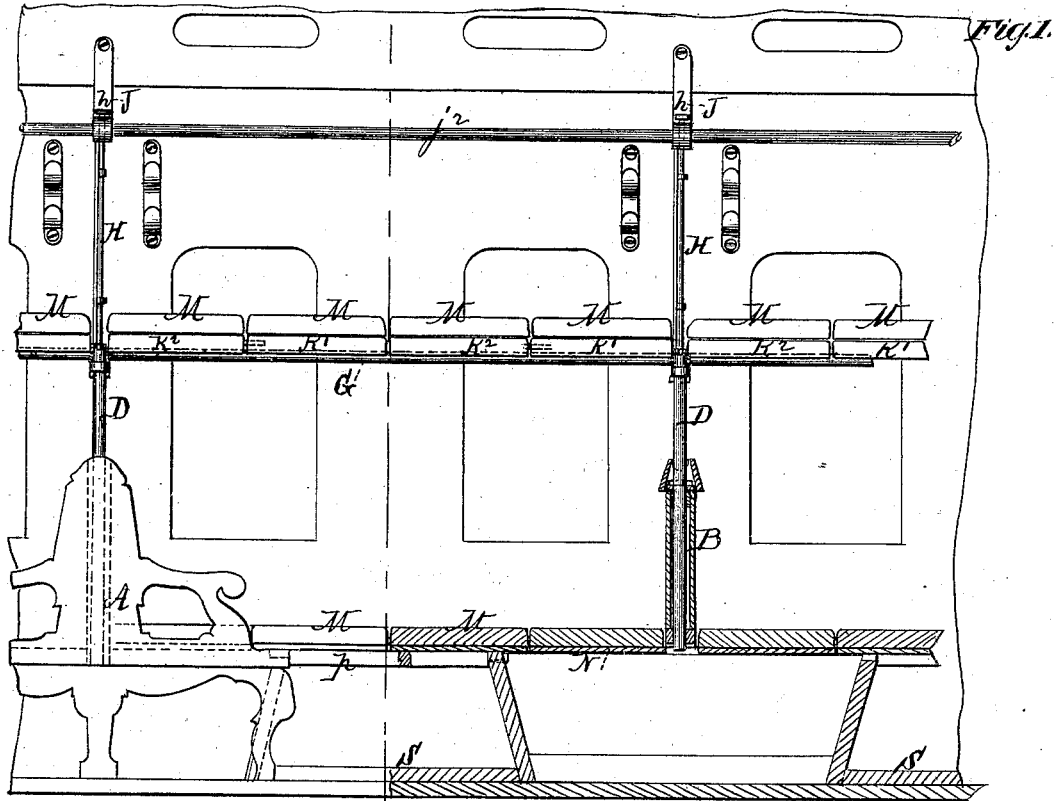
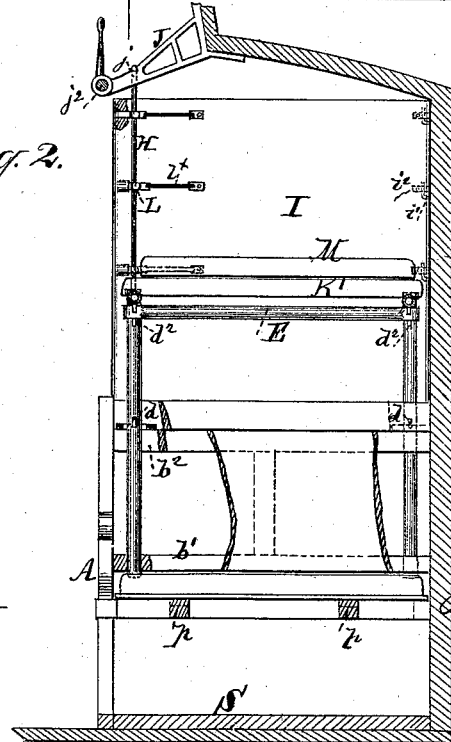

Fig. 2.



Witnesses  
 John Becker  
 Fred Wagner

J. F. Goodridge  
 Cybis Attorney  
 Brown & Allen

J. F. GOODRIDGE.  
SLEEPING-CAR.

No. 169,633.

Patented Nov. 9, 1875.

Fig. 3.

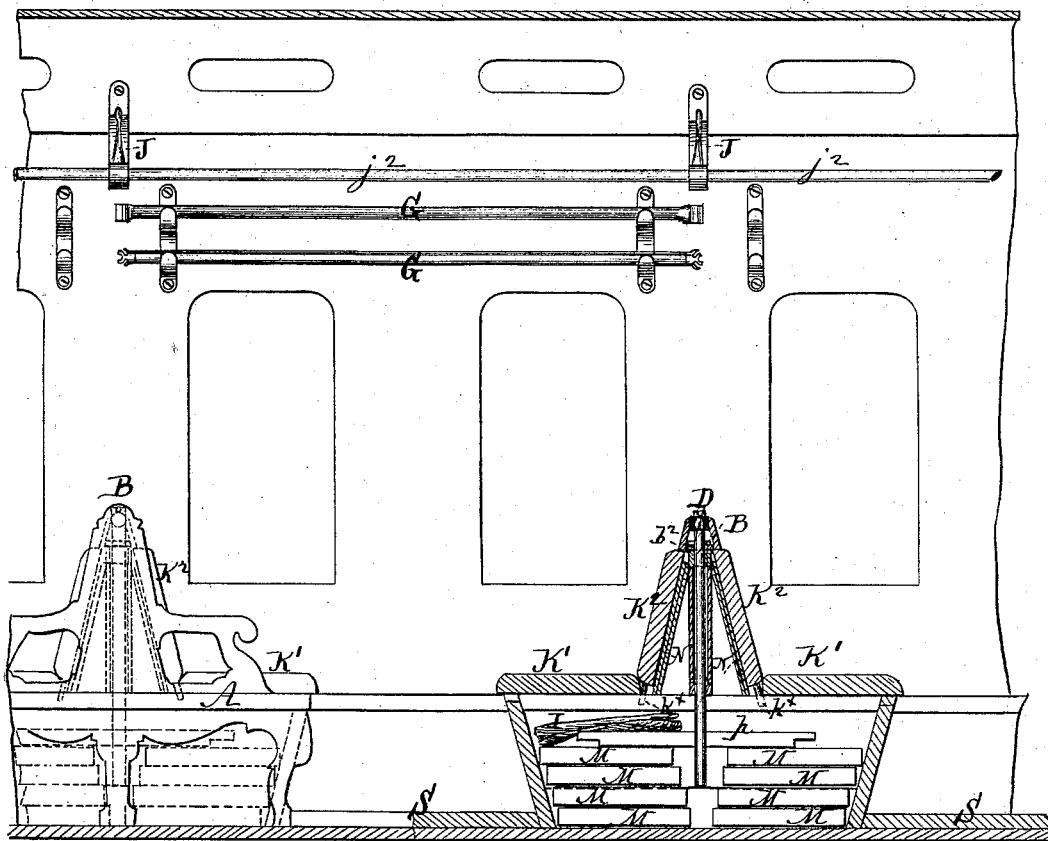

Fig. 4.

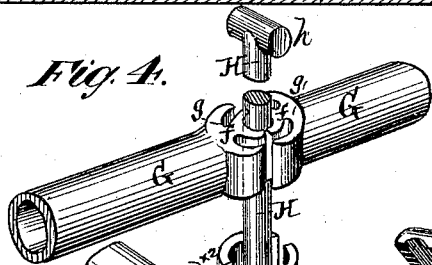

Fig. 7.

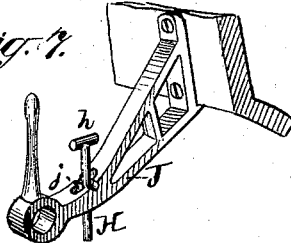

Fig. 6.

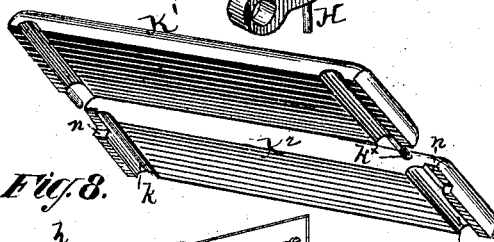

Fig. 5.

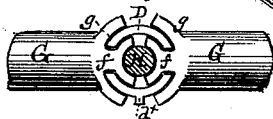
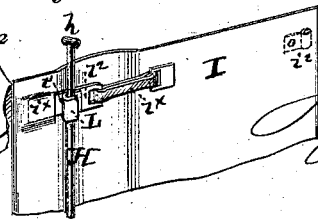

Fig. 8.



Witnesses  
 John Becker  
 and  
 Geo. W. Maynes

J. F. Goodridge  
 by his Attorneys  
 Brown & Allen

# UNITED STATES PATENT OFFICE

JAMES F. GOODRIDGE, OF NEW YORK, N. Y.

## IMPROVEMENT IN SLEEPING-CARS.

Specification forming part of Letters Patent No. 169,633, dated November 9, 1875; application filed August 9, 1875.

*To all whom it may concern:*

Be it known that I, JAMES F. GOODRIDGE, of New York, in the county and State of New York, have invented certain Improvements in Sleeping-Cars; and I do hereby declare that the following is a full, clear, and exact description of the same, reference being had to the accompanying drawing, which forms part of this specification, in which—

Figure 1 is a longitudinal vertical sectional view of a portion of a sleeping-car constructed according to my invention, with the parts in position for use as a sleeping-car. Fig. 2 is a transverse vertical sectional view of the same. Fig. 3 is a longitudinal vertical sectional view of the portion shown in Fig. 1, with the parts in position for day use. Figs. 4, 5, 6, 7, and 8 are detail views hereinafter more particularly referred to.

My invention consists, mainly, in the use of tubing for supporting the upper berths in a sleeping-car; and further, in certain details of construction and arrangement, whereby the making-up of the berths is facilitated, the stowing of the bedding when not in use is provided for, and simplicity, economy, cleanliness, and lightness are secured.

The car-seats A are arranged in pairs, facing each other, each pair forming what is known as a "section," as is usual in sleeping-cars, with the backs of the seats of each pair close to the backs of the seats of other pairs, and with a bulk-head, B, between each two contiguous backs. In the bulk-head B I place two rails,  $b^1 b^2$ , one near the top, and the other somewhat above the level of the seats, arranging them parallel with each other and with the lengths of the backs. In these rails, near their ends, are holes for the reception of tubes D, which form the upright supports for the upper berths. The holes in the lower rails  $b^1$  are round, and the tubes D fit snugly therein, so as to slide up and down freely, but at the same time be supported steadily. The holes in the upper rails,  $b^2$ , have two lateral notches diametrically opposite each other, for the purpose hereinafter described. The upper rails  $b^2$  are provided with metal plates  $b^{2x}$ , shown in detail in Fig. 4, for the purpose of re-enforcing the holes and preventing too great wear thereof; and the holes in the lower rails

may also be re-enforced by metal plates. The plates  $b^{2x}$  have notches or grooves  $c c$  in their upper sides, opposite each other, and midway between the lateral notches  $c^x c^x$ , for the purpose hereinafter described. The tubes D are each provided, about midway of their length, with two lugs or projections,  $d d$ , opposite each other, for engagement with the lateral notches  $c^x c^x$ , and also with the grooves  $c c$ ; and at their upper ends are two other lugs or projections,  $d^2 d^2$ , for supporting a transverse brace, hereinafter described. These lugs or projections may be formed on the tubes, or may consist of pins or keys driven through holes in the tube, so as to project therefrom. The two tubes D in each pair—that is to say, the two tubes which are located between two contiguous backs—are connected near their upper ends by a tube, E, running transversely of the car, the connection being made by means of the ordinary T-joints, such as are used by gas-fitters for joining pipes at right angles to each other, or by means of rings or eyes formed on or attached to the ends of the tube E in any suitable manner. These T-joints, rings, or eyes, fit over the upper ends of the tubes D, above the lugs  $d^2$ , so as to allow said tubes D to turn freely, and they are prevented from upward displacement by means of projections  $d^x$ . The tubes E thus arranged serve as braces to prevent lateral vibration of the upright tubes D.

For supporting the upper berth in each section I employ two tubes, G, arranged longitudinally of the car in horizontal positions, and supported by the upright tubes D. The ends of the horizontal tubes G are provided with claws  $g$ , of peculiar construction, (see Fig. 4,) for connecting them with the upper ends of the upright tubes D. One portion of the claw  $g$  is formed for engagement with the inner surface of the upright tube, and another portion for engagement with the outer surface thereof, and the two portions are connected by a shank or neck,  $f$ , for engagement with a notch,  $d^{x2}$ , in the upper portion of the tube D.

The tubing referred to herein may be of any suitable description; but I prefer to use ordinary gas-pipe, which may be plated or ornamented in any suitable manner. In some

cases rods may be substituted for the tubes, but I prefer tubing for the reason that, by its use, I obtain the requisite strength with less weight than by using rods.

In the upper edge of the bulk-head B of each section is a semi-cylindrical groove for the reception of the transverse horizontal tube E.

When the car is arranged for day service, the tubes G may be placed in brackets near the top of the car, as shown in Fig. 3, or may be placed in position to form hand-rails, or may be otherwise disposed of, while the upright tubes D occupy their lowest position in the bulk-head, between the backs of the seats, and the transverse tubes E lie in the grooves in the upper edges of the bulk-heads, and form an ornamental finish for the same.

When the car is to be arranged for service as a sleeping-car, the upright tubes D are raised until the lugs *d d* are above the upper rail, said lugs passing through the lateral notches *c<sup>x</sup> c<sup>x</sup>*, and are given a quarter turn so as to bring the lugs *d* to a position at right angles with the first position, and then lowered until the lugs *d d* rest in the grooves *c c*. The longitudinal horizontal tubes G are then put in place by connecting the claws *g* with the upper ends of the tubes D, so that one portion of the claw is inside the tube, another portion is outside, and the intermediate shank or neck *f* is in the notch *d<sup>x2</sup>*, as shown in detail, Fig. 5. Thus arranged, the horizontal tubes G serve as side rails for supporting the bedding of the upper berth, as shown in Figs. 1 and 2.

For supporting the outer edges of the partitions between the upper berths I employ tubes or rods H, which slide telescopically in the upright tubes D when not in use, and have their lower ends supported thereby when in use. The upper ends of the tubes or rods H may be provided with T-heads *h* for engagement with slots and notches *j* in the brackets J, (see Figs. 1, 2 and 7,) which carry the curtain-rod *j<sup>2</sup>*, or the upper ends of the tube or rods H may be hooked over the curtain-rods, or secured in any other suitable manner.

The partitions I (see Figs. 2 and 8) are made of leather, canvas, or other suitable material, and may be embroidered or ornamented, as desired. The inner edge of the partition I is attached to the side of the car by hooks and eyes *i<sup>2</sup> i<sup>2</sup>* of any suitable description, but the outer edge is attached to the rod H by means of hooks L, of peculiar construction. Each hook L has a projecting tongue, *l<sup>1</sup>*, extending toward the outer edge of the partition, and a similar tongue, *l<sup>2</sup>*, extending in the opposite direction, so that when in place the rod H is engaged with the hook L about midway between the ends of the tongues. The inner tongue *l<sup>2</sup>* is attached to the partition I by means of a spring or elastic band, *l<sup>x</sup>*, and the outer tongue *l<sup>1</sup>* slides in a pocket, *i<sup>x</sup>*, formed in or attached to the partition I. By this construction and arrangement the partition I is

enabled to extend beyond the rod H and tube D a sufficient distance to bring its outer edge in line with the curtain-rod *j<sup>2</sup>* and the outer ends of the seats A, and thus close a gap which would otherwise exist between the curtain and the edge of the partition when the section is made up. By means of the spring or band *l<sup>x</sup>* the partition is held taut, and by means of the tongues *l<sup>1</sup>* in the pocket *i<sup>x</sup>* the projecting edge of the partition is held in place to close the gap, and is prevented from vibrating or flapping about, as would be the case without some stiffening and supporting device.

For supporting the mattress of the upper berth of each section I employ the cushions K<sup>1</sup> K<sup>2</sup> of the seats and backs belonging to such section. On the under side of the frame of each cushion I form grooves or notches *k*, (see Fig. 6,) for engagement with the tubes G, by which means the frames are held firmly and steadily in place, and are thus utilized and form a reliable and comfortable bed-bottom. The mattresses M are placed upon the cushions, as shown in Figs. 1 and 2. The back cushions K<sup>2</sup> are provided with pins *k<sup>x</sup>* for holding them in place against the backs of the seats by entering sockets in the framework, as shown in Fig. 3. When the cushions are used for supporting the mattress the pins *k<sup>x</sup>* enter recesses *n* in the next adjacent cushion K<sup>1</sup>.

For supporting the bedding of the lower berth I may use slats or boards, N, which, when not in use, may be stored within the back cushions, as shown. When in use they may be supported by bars *p*, having their ends resting on the edges of the seats, as shown in Fig. 1.

The mattresses for each berth are made in any desired number of sections, and may be arranged to break joints with the cushions and the slats or boards.

When the car is arranged for day use the mattresses are packed in the spaces under the seats, as shown in Fig. 3.

In order to render the seats of a comfortable height for day use, and at the same time provide ample room for stowing the bedding without the necessity for extending the space below the floor of the car, as has been proposed in some sleeping-cars, I re-enforce the floor proper by a false or additional floor, S, of the desired thickness, between the two seats of each section, as shown in Figs. 1, 2, and 3, by which means I am enabled to construct the seats higher than usual, and at the same time provide for the comfort of the occupants.

When only the lower berth of a section is to be used, the tubes G may remain in place in their brackets, and the cushions may be used for supporting the lower berth, by which means the occupant of the section may have the benefit of the entire height thereof. The tubes G may also remain in the bracket when the car is used as a compartment-car; in

which case the partitions I remain in place between the sections, and the seats remain as shown in Fig. 3.

By the construction and arrangement above described I am enabled to secure economy, simplicity, cleanliness, and lightness, with the additional advantage of carrying all the weight on the bottom of the car instead of having a great portion of the weight suspended from the top, as is the case in some sleeping-cars now in use.

What I claim as new, and desire to secure by Letters Patent, is—

1. A sleeping-car, having the upper berths supported by tubes or rods sliding vertically in guides or bearings in the lower part of the car independent of any support in the upper part, substantially as herein described.

2. The plates  $b^{2x}$ , on the rails  $b^2$ , in combination with the lugs or projections  $d^2$  on the tubes D, as shown and described, for the purpose specified.

3. The combination, with the bulk-heads B, of the tubes D and transverse braces E, substantially as shown and described.

4. The combination of the plates  $b^{2x}$ , having the notches  $c^x$  and grooves  $c$ , with the tubes D, having the projections  $d^2$ , substantially as and for the purpose specified.

5. The combination, with the upright tubes D, of the longitudinal tubes or rods G, constituting the side rails for supporting the upper berth, substantially as described.

6. The combination, with the side rails G, of the seat and back cushions  $K^1 K^2$  for sup-

porting the bedding of the upper berth, substantially as described.

7. The partition I, provided with the hooks and eyes  $i^1 i^2$  and the hooks or clasps L constructed as described, in combination with the rod H and tube D, and the side wall of the car, substantially as and for the purpose set forth.

8. The combination, with the rod H, and tube D, and the partition I provided with the pocket  $i^x$ , of the hooks L, provided with the tongues  $l^1 l^2$ , and the spring or elastic band  $l^x$ , substantially as and for the purpose described.

9. The combination of the bulk-heads B, the upright tubes D, transverse braces E, rods H, and partitions I, whereby a single-berth "section" for night use or a "compartment" for day use may be formed without the side rails G, substantially as described.

10. The combination of the transverse brace E and the groove in the upper edge of the bulk-head B, whereby said brace is provided with a seat when not in use, and forms an ornamental molding, substantially as described.

11. The combination, with the seats A and the floor proper, of the false or additional floor S, whereby the seats are made of a convenient or comfortable height, and ample room is provided beneath them for storing bedding, &c., substantially as described.

JAMES F. GOODRIDGE.

Witnesses:

BENJAMIN W. HOFFMAN,  
FRED. HAYNES.