

C. G. MORGAN.  
LIQUID MEASURES.

No. 169,652.

Patented Nov. 9, 1875.

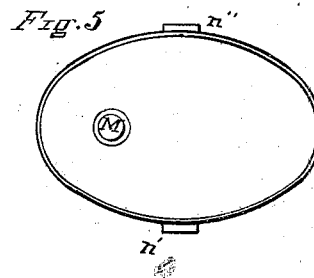
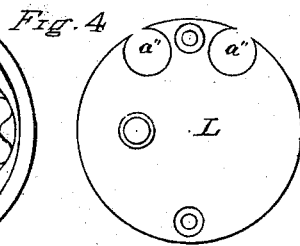
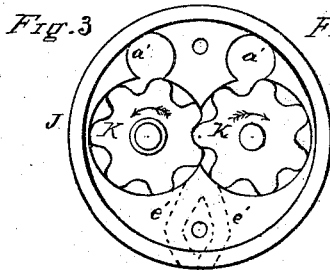
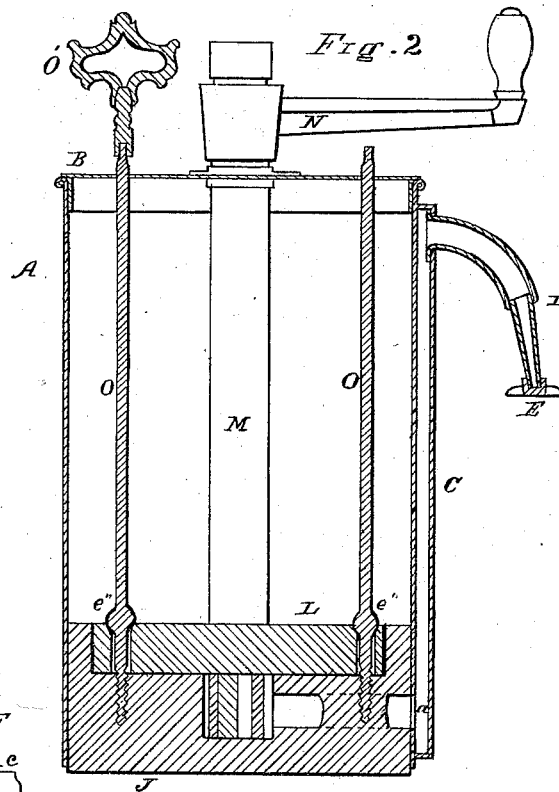
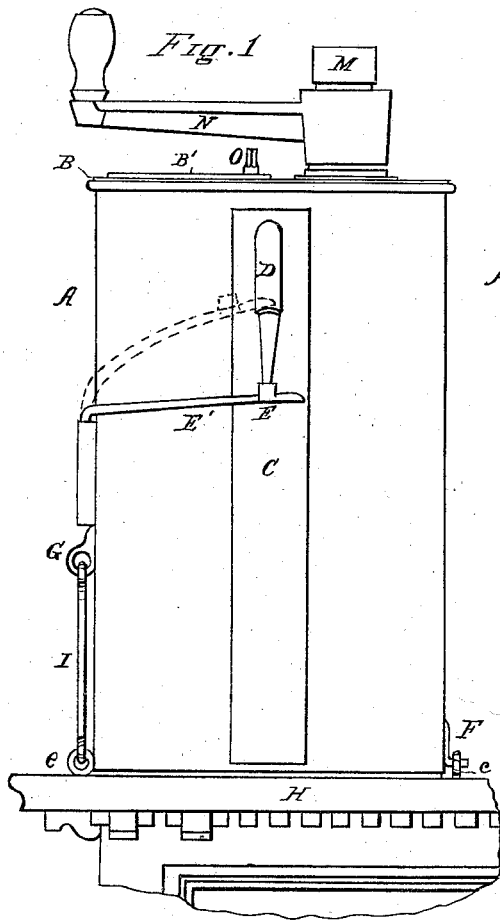

WITNESSES.

*Franklin Danson*  
*W. H. Betts*

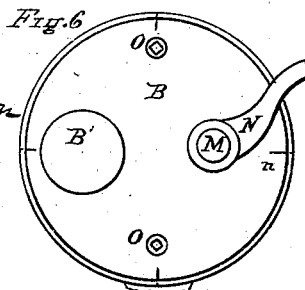

INVENTOR.

*Charles G. Morgan*  
*By Bradley & Mann*  
*his atty.*

# UNITED STATES PATENT OFFICE.

CHARLES G. MORGAN, OF BRISTOL STATION, ILLINOIS.

## IMPROVEMENT IN LIQUID-MEASURERS.

Specification forming part of Letters Patent No. **169,652**, dated November 9, 1875; application filed August 12, 1875.

*To all whom it may concern:*

Be it known that I, CHARLES G. MORGAN, of Bristol Station, in the county of Kendall and State of Illinois, have invented a new, useful, and Improved Oil Tank or Measurer, of which the following is a full, clear, and exact description, which will enable others skilled in the art to which my invention appertains to make and use the same, reference being had to the accompanying drawing forming a part hereof, and in which—

Figure 1 is a side elevation of a tank or vessel embodying my invention; Fig. 2, a vertical central section of the same; Fig. 3, a top or plan view of the interior parts; Fig. 4, a like view of the lid or cover of the parts shown in Fig. 3; Fig. 5, a side view, representing a modification in the form and arrangement of the pump; and Fig. 6 a top view of the tank or vessel.

Like letters of reference indicate like parts.

My object is to provide improved tanks or vessels wherein druggists and others may store, for retail, oils and other similar liquids, and from which they may draw, with facility and certainty, the various smaller amounts called for by their customers. To this end my invention consists of a tank or vessel adapted to contain the liquids referred to, and combined, substantially as hereinafter described, with a force-pump for ejecting any given quantity of liquid from the tank with certainty, and at any time.

My invention also consists of several details, substantially as hereinafter specified, relating to the tank and pump, and to the means employed for combining the several parts with advantage, for the purposes set forth.

In the drawings, A represents the tank or vessel, adapted to contain the oil or other liquid to be stored therein. B is the lid of the tank, and B' a lid or cover, arranged over an opening in the lid B. C is a half-cylindrical tube attached to the outside of the tank, and closed at the top and bottom. *a* is an opening in the wall of the tank, and is arranged to enter the tube C. D is a nozzle, also entering the tube C. E is a nozzle-stopper, fastened to a yielding arm, E', pivoted

to the body of the tank. The position of the arm E', when free, is represented by the broken lines in Fig. 1. F is a lug attached to the lower part of the tank, and G is an eye also attached to the tank, and arranged as shown. H represents a shelf or counter, and *e e* are eyes attached thereto. I is a hook linked into one of the eyes *e e*.

In the example shown the tank is cylindrical; but its form is not essential to my invention. The form and position of the tube C may be varied, as it is only intended to perform the function of an eduction in connection with the tank, pump, and nozzle, as will hereinafter more fully appear. Neither is it essential that the arm E', provided it has a laterally-yielding movement, should be pivoted to the tank. The tank may either be provided with a bottom in the usual manner, or in the manner hereinafter described.

J is a block, which, in the example shown, is nicely fitted into the lower end of the tank, and constitutes its bottom. This block is nicely mortised to receive two spur-wheels, *k* and *k*, which have a bearing therein, and are arranged, as shown, to engage each other. *a' a'* are recesses or mortises also sunken into the block J, and intersecting or communicating with the mortises in which the wheels *k k* rest. The broken lines shown at *e' e'*, Fig. 3, represent a channel or eduction terminating at one end in the mortises in which the wheels *k k* rest, and at the other in the opening *a*. L is a lid or cover fitted nicely into the upper end of the block J. *a'' a''* are openings corresponding to the openings *a' a'*. M is a shaft passing freely through the parts B and L, and rigidly attached to one of the wheels K K. N is a crank or handle for rotating the shaft M. O O are rods passing freely through the parts B and L. The lower ends of these rods are screw-threaded, and enter female screws in the block J, as represented in Fig. 2. *e'' e''* are collars on the rods O O. These rods may be turned by means of a key, O. The lid or cover B should be marked, as shown at *n*, for the purposes hereinafter set forth.

Instead of arranging, horizontally, the parts which constitute the pump, they may be enclosed in an independent case, and the whole

arranged vertically in the tank; and in the latter case the tank should be provided with a bottom in the usual manner.

The modifications required, when the wheels K K are arranged vertically, are represented in Fig. 5, wherein  $n'$  represents the induction, and  $n''$  the eduction. The shaft M and rods O O are also there shown as entering the parts horizontally. In all essential features of construction the pump represented in Fig. 5 is the same as the one already described.

The operation of the device now described is as follows: The tank is first filled with a suitable amount of oil, either the lid B or B' being removed for that purpose. This oil finds its way through the openings  $a'' a''$  and  $a' a'$  into the pockets formed by the cogs or spurs of the wheels K K. These wheels, when rotated in the direction indicated by the arrows shown in Fig. 3, carry the oil around toward the eduction  $e'$ , and the oil thus confined in the pockets has no escape (except as hereinafter mentioned) until each pocket reaches the eduction, it being understood that the part L lies closely against the block J and the wheels K K. When the cogs or spurs reach the eduction the cogs on each wheel, by entering the pockets in the other, force out the oil into the eduction-channel  $e' e'$ , into the tube C, and thence into the nozzle. The end of the nozzle should be small enough to slightly enter the neck of small bottles.

In order to transfer the contents of the tank into the bottle the stopper E should be removed from the nozzle, and the latter inserted into the bottle. One rotation of the crank will force a certain quantity of the oil (an ounce, for example) into the vial; two rotations, two ounces, and so on, according to the quantity desired.

In order to determine with certainty when a complete rotation of the crank has been made, I make the mark  $n$ , as shown, and before referred to, and make this the starting and stopping point, and the lid B may also be graduated to indicate a half or even a smaller fraction of a complete rotation of the shaft, thus also indicating the amount forced out when the amount is less than an ounce.

If one rotation of the crank should not correspond to the unit of measurement already referred to, but force out more than an ounce, the rods O O should be so turned that the collars  $e'' e''$  will slightly release the part L. Then, during the rotation of the crank, some of the oil will escape from the pockets into the body of the tank instead of being forced out through the eduction and nozzle, and in this manner the amount discharged by each rotation can always be regulated with certainty.

When the bottle or other vessel has received

its supply it should be removed, and the stopper applied to the nozzle.

While the crank is at rest, and during the interval existing between the removal of the bottle and the act of arranging the stopper on the nozzle, the oil in the tube C and nozzle cannot flow back into the tank, the back flow being prevented by the interlocked teeth of the wheels K K. The oil itself forms, to some extent, a packing in the shallow spaces between the other parts.

Tanks of various sizes may be employed for the purposes set forth, and the pumps may be adapted to force out either a pint, quart, gallon, or larger quantity during each rotation of the crank.

By employing a force-pump the contents may be more rapidly discharged through the small nozzle than through a much larger opening when pressure is not exerted.

The stopper E, by being mounted on a yielding arm, is rendered effectual for the purpose for which it is intended, cannot be lost, and may be removed from the nozzle and replaced with facility.

The manner of fastening the tank to the shelf or counter is represented in Fig. 1. In order to fasten the tank it should be tilted sufficiently to allow the lug F to enter the eye not occupied by the hook. The tank should then be allowed to resume its horizontal position, and the hook arranged in the eye G.

The device, as a whole, is simple in its construction and operation, and greatly facilitates the work of drawing off and measuring the oil.

Having thus described my invention, what I claim as new, and desire to secure by Letters Patent, is—

1. In an oil tank or measurer, consisting of a force-pump arranged within an outer vessel, the adjustable lid or cover L, constituting a part of the forcing apparatus, whereby a greater or less quantity of oil, after having been drawn from the said vessel into the pump may be returned from the latter into the former before being discharged through the nozzle D, substantially as specified.

2. In combination the tank A, provided with an eduction-tube and nozzle, C D, the recessed block J, the adjustable lid L, the spur-wheels K K, the shaft M, and the screw-rods O O, provided with the collars  $e'' e''$ , all constructed and arranged for operation together, substantially as and for the purposes specified.

3. The stopper E, mounted on the yielding arm E', in combination with the nozzle D, substantially as and for the purposes specified.

CHARLES G. MORGAN.

Witnesses:

A. N. BEEBE,  
H. L. MOORE.