

A. M. HOWARD.  
TYPE-MACHINE.

No. 169,701.

Patented Nov. 9, 1875.

Fig. 1

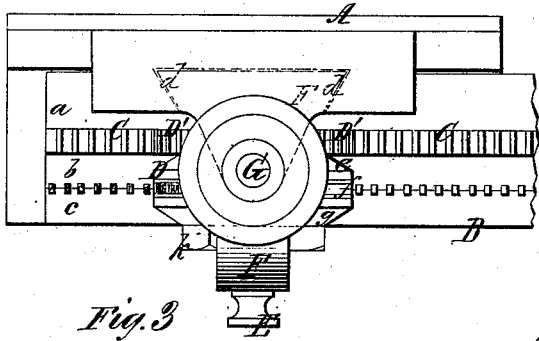

Fig. 2

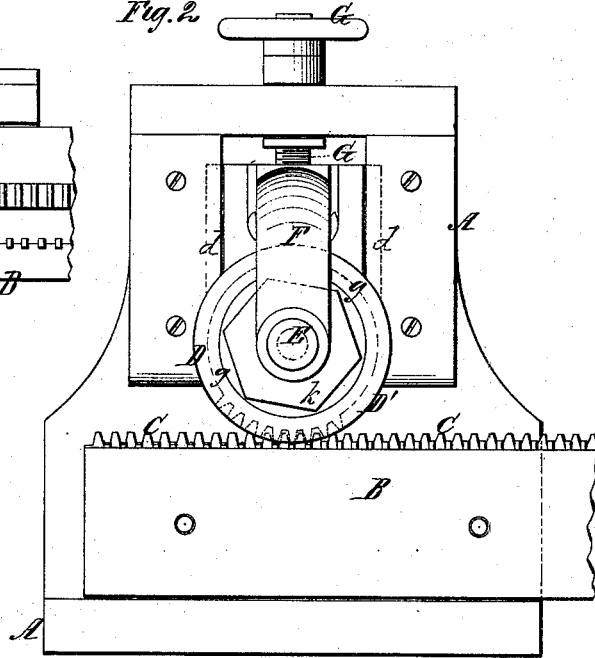

Fig. 3

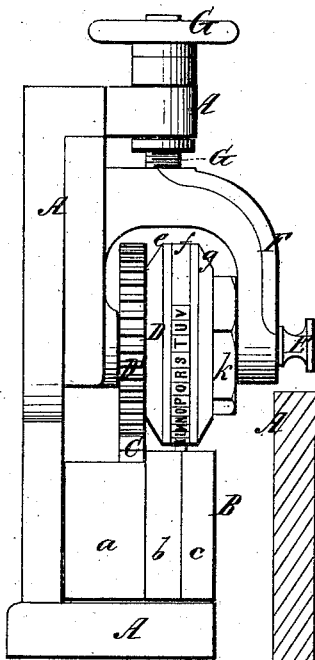

Fig. 4

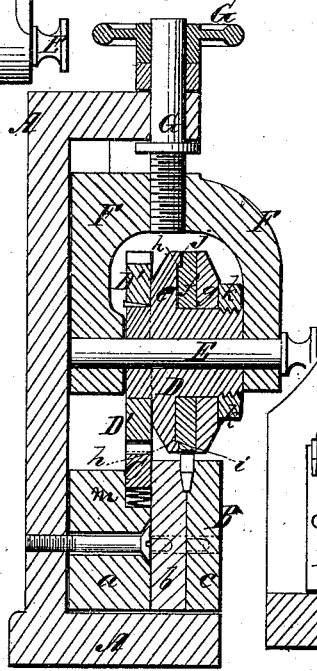

Fig. 5

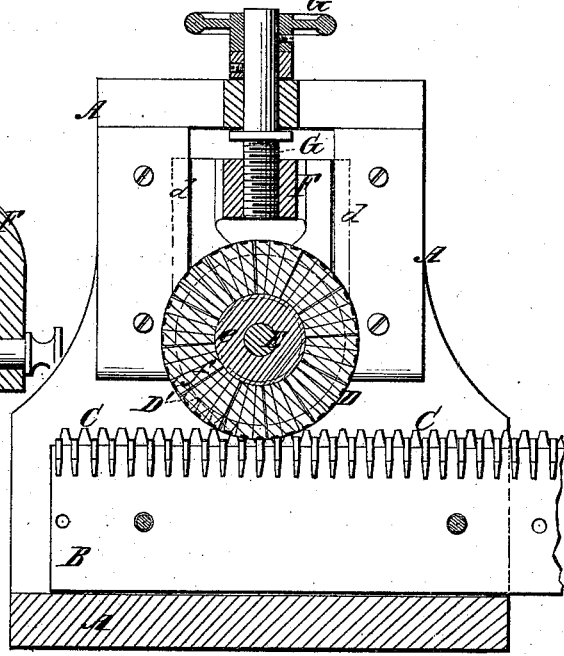

Fig. 6

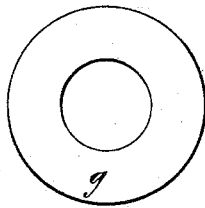

Fig. 7

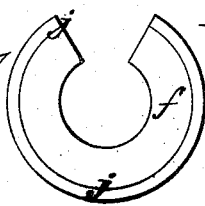
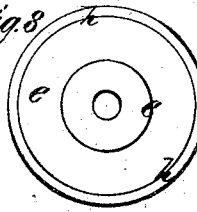

Fig. 8



Witnesses:  
James Martin for  
J. Campbell

Inventor:  
A. M. Howard  
by  
Wm. L. L. L.

# UNITED STATES PATENT OFFICE.

ANSON MERRICK HOWARD, OF ILION, NEW YORK.

## IMPROVEMENT IN TYPE-MACHINES.

Specification forming part of Letters Patent No. **169,701**, dated November 9, 1875; application filed June 3, 1875.

*To all whom it may concern:*

Be it known that I, ANSON M. HOWARD, of Ilion, county of Herkimer and State of New York, have invented a new and Improved Machine for Making Hard-Metal Type; and I do hereby declare that the following is a full, clear, and exact description thereof, reference being had to the accompanying drawings making part of this specification, in which—

Figure 1 is a top view of my improved machine for making hard-metal type. Fig. 2 is a front view, Fig. 3 an end view, Fig. 4 a transverse section, and Fig. 5 a longitudinal section, of the said machine. Figs. 6, 7, and 8 are details, showing inner face views of the parts of the type-wheel.

The object of my invention is to effect the reproduction, by machinery, of single hard-metal type, or monogram-type. It consists, first, in the combination of a bed-clamp, formed of three plates, for confining a gage-feeding rack, and single pieces of metal for writing and monogram type, and a clamp constructed to receive and confine single type or monogram-type while they are being used for making raised letters on blanks, and then permitting the original type to be removed, and the blanks with raised letters to be placed and confined in it, and used for producing fac-similes of the original hand-engraved type, and then permitting the type, which are reproductions of the original hand-engraved type, to be placed and confined in it, and used for making type and monograms for writing-machines and other machines, the aforesaid clamping-wheel being placed on a shaft or arbor, which carries a toothed feeding-wheel, which gears with a toothed feeding rack directly under it. It consists, second, in the combination of a toothed gage and feeding-wheel on the shaft of the type carrying and clamping wheel, and a toothed gage and feeding-rack, which is capable of yielding vertically, applied on the clamp which carries the blanks for the writing or monogram type, for the purpose of gaging the operation of the machine, and insuring the production of type with letters centrally located upon the base portion of the metal of which the type are formed.

To enable others skilled in the art to make

and use my invention, I will proceed to describe it.

A is a frame or bracket, shaped and constructed so as to form an attachment to any ordinary lathe or iron-planing machine. This frame or bracket, however, may be a part of a complete machine designed especially for making type, if found most desirable. On the bed of this frame a clamp, B, is fitted to reciprocate. This clamp is formed of three plates, *a b c*, screwed together. Between two of the plates *a* and *b* springs *m* are placed, and on these springs a toothed gage and feeding-rack, C, is arranged and suitably confined, and between the plates *b* and *c* blanks for the type are confined, so as to move up and down freely, suitable half-sockets being formed in the plates for the admission of these blanks between the plates. The feeding-gage rack is made capable of yielding up and down, so that its teeth may be kept in gear with the wheel, working with it from the commencement to the completion of the operation, and when the last compression or swaging action takes place it may be seated firmly on a solid bed. The adjustability of the die-wheel, which will be presently described, requires this spring or yielding feeding-gage rack to be used, in order that when the impression upon the metal set in the bed is just begun, the feeding and gaging wheel and rack shall be perfectly in gear, and, as the impression is still further advanced, and the die-wheel requires to be lowered, the feeding-rack will yield and permit the die-wheel to be lowered, and, finally, when the impression is about completed, and the die-wheel has been lowered to the full extent required, the rack will rest upon a solid bed, the springs having been compressed so closely that their elasticity is overcome for the time being. It is important that the last operation of compression or swaging shall be performed upon a solid foundation, in order to prevent the type and dies from changing their relation to one another in the slightest degree. Directly above this clamp a clamping-wheel, D, with a gaging and feeding toothed wheel, D', attached to it, is hung upon a shaft, E, in a hanger, F, which is fitted to the bracket by means of dovetail connections *d*, and ad-

justed up and down toward or from the clamp B by means of a hand-screw, G. This clamp is composed of three plates, *e f g*. The plate *e* is chambered, so as to form an annular shoulder at *h*, for shoulders *i* on the type to bear against when the type are clamped in position. This shoulder prevents the type falling out of the wheel when the machine is in operation. The plate *f* is grooved at *j*, in order to receive the flange which forms the shoulder of the plate *e*, and it is made to bear firmly against the side of the type, and thus clamp them against the plate *e* by means of the plate *g* and a nut, *k*, which latter screws on the end of the hub of the plate *e*. The plate *f* will be cut away to a greater or less extent, so as to form a greater or less part of a circular disk, according to the number of die-type used in the clamp; and in the event that the whole of plate *e* is occupied with die-type, this plate will not be necessary, and "spaces," with the clamping-plate *g*, only will be used.

The type which are used as die-type are made with working-faces which are segments of the exterior of a cylinder, and the blanks acted upon by them are made to have working-surfaces which are concave or segments of the interior of a cylinder.

The manner of clamping the type and blanks in the wheel D and clamp B is clearly shown in the drawings, and it will be understood that the motion of the rack or of the wheel causes the die-type in the wheel to roll over the blanks for the type in the clamp B, and

thereby swage the letters upon the blanks. The movement of the wheel, with letters of the wheel and of clamp B, is uniform with respect to one another, for the feeding-rack or toothed wheel is constructed to act as a gage, by reason of the respective spaces and teeth of the wheel and rack corresponding exactly to the respective type in the wheel, and respective blanks for type in the clamp B.

The great utility of my invention lies in the saving of expense in the manufacture of the type, and in not being obliged to make an entirely new die in the event of one of the die or pattern type being broken off or worn out, as would be the case if the die-type were not made single and clamped at a proper distance apart in the wheel.

What I claim is—

1. The clamping-wheel for confining single type or monogram-type, in combination with the clamp formed of three plates for confining the gage-feeding rack, and single pieces of metal for writing or monogram type, substantially as and for the purposes described.

2. The combination of a toothed gage and feeding-wheel, a type-clamping wheel, a toothed and vertically-yielding or spring gage and feed-rack, and the clamp for the blank type-metal, and spring and gage feeding rack, substantially as and for the purposes described.

ANSON MERRICK HOWARD.

Witnesses:

J. B. PELTON,

W. K. JENNE.