

J. C. MITCHELL.
CAR-COUPLING.

No. 169,720.

Patented Nov. 9, 1875.

Fig. 1.

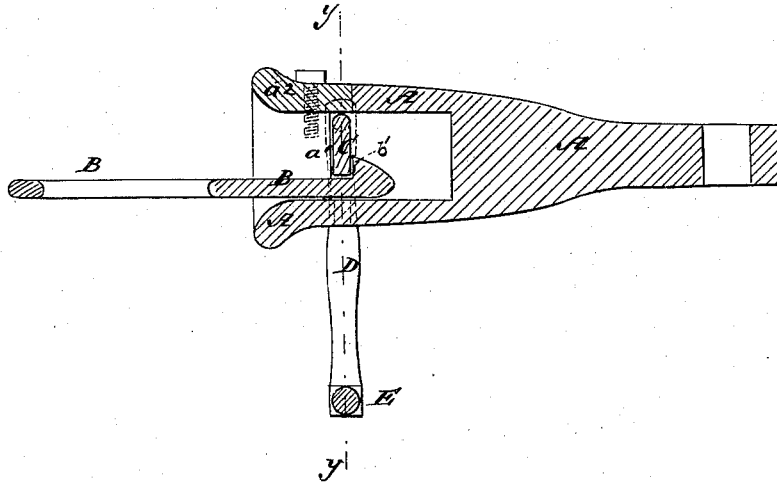
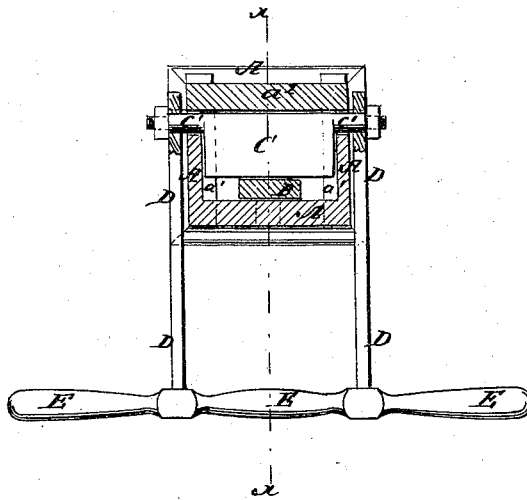

Fig. 2.



WITNESSES:

E. Woff
A. J. Terry

INVENTOR:

James C. Mitchell

BY

Munniff

ATTORNEYS.

UNITED STATES PATENT OFFICE.

JAMES C. MITCHELL, OF LANCASTER, NEW HAMPSHIRE.

IMPROVEMENT IN CAR-COUPINGS.

Specification forming part of Letters Patent No. **169,720**, dated November 9, 1875; application filed September 4, 1875.

To all whom it may concern:

Be it known that I, JAMES C. MITCHELL, of Lancaster, in the county of Coos and State of New Hampshire, have invented a new and useful Improvement in Coupling for Freight-Cars, of which the following is a specification:

Figure 1 is a vertical longitudinal section of my improved coupling, taken through the line $x x$ of Fig. 2. Fig. 2 is a vertical cross-section of the same, taken through the line $y y$, Fig. 1.

Similar letters of reference indicate corresponding parts.

The invention will first be described in connection with drawing, and then pointed out in the claim.

A is the draw-bar, the mouth of the cavity of which is made hopper-shaped to guide the coupling bar or link B into proper position. The inner part of the cavity of the draw-bar A is made wider than the outer part, to form shoulders a^1 for the ends of the coupling-plate C to rest against to sustain the draft-strain. Upon the upper part of the side edges of the coupling-plate C are formed gudgeons or pivots c' , which work in bearings in the sides of the coupling-bar A, and have nuts screwed upon their ends to prevent lateral movement. The pivots c' are secured in their bearings by the top plate a^2 of the draw-bar A, which is made detachable, and which is secured in place by screws, as shown in Fig. 1.

The detachable top a^2 enables the coupling-plate C to be conveniently put in and taken out, as may be required. The lower edge of the coupling-plate C does not reach quite to the bottom of cavity of the draw-bar A, a space being left sufficient to receive the body of the coupling-bar B. The coupling-bar B has a head or shoulder, b' , formed upon the upper side of one or both ends, and the

upper side of said end or ends is beveled off, so that, when the cars are run together, the end of the entering coupling-bar may push back the coupling-plate, which, as soon as the head b' has passed its lower edge, swings forward, so that the shoulder of the head b' may rest against the rear side of said edge and sustain the draft-strain.

The bar B may be made straight to couple cars of the same height; or it may be bent to couple cars of different heights; or it may have a head, b' , at one end, and a slot at the other end, as shown in Fig. 1, to couple a car provided with my improved coupling with one provided with an ordinary coupling.

Upon the pivots c' of the coupling-plate C are placed the upper ends of two levers, D, which are secured in place by the nuts screwed upon said pivots, so that the coupling-plate C may be swung back to uncouple the cars by operating the said levers D. The ends of the levers D are connected beneath the draw-bar A by a cross-bar, E, the ends of which project, so that they may serve as handles to enable the levers D to be operated to uncouple the cars from either side of said cars. The levers D and cross-bar E also serve as a weight to hold the coupling-plate C down to its place.

Having thus described my invention, I claim as new and desire to secure by Letters Patent—

The combination of draw-bar, having shoulders a^1 and detachable top plate a^2 , and a coupling-plate, having the pivots c' , as and for the purpose specified.

JAMES C. MITCHELL.

Witnesses:

CHAS. E. ALLEN,
C. W. ROBY,
J. M. KIMBALL.