

G. H. M. MUNTZ.  
MACHINES FOR MAKING TUBING.

No. 169,723.

Patented Nov. 9, 1875.

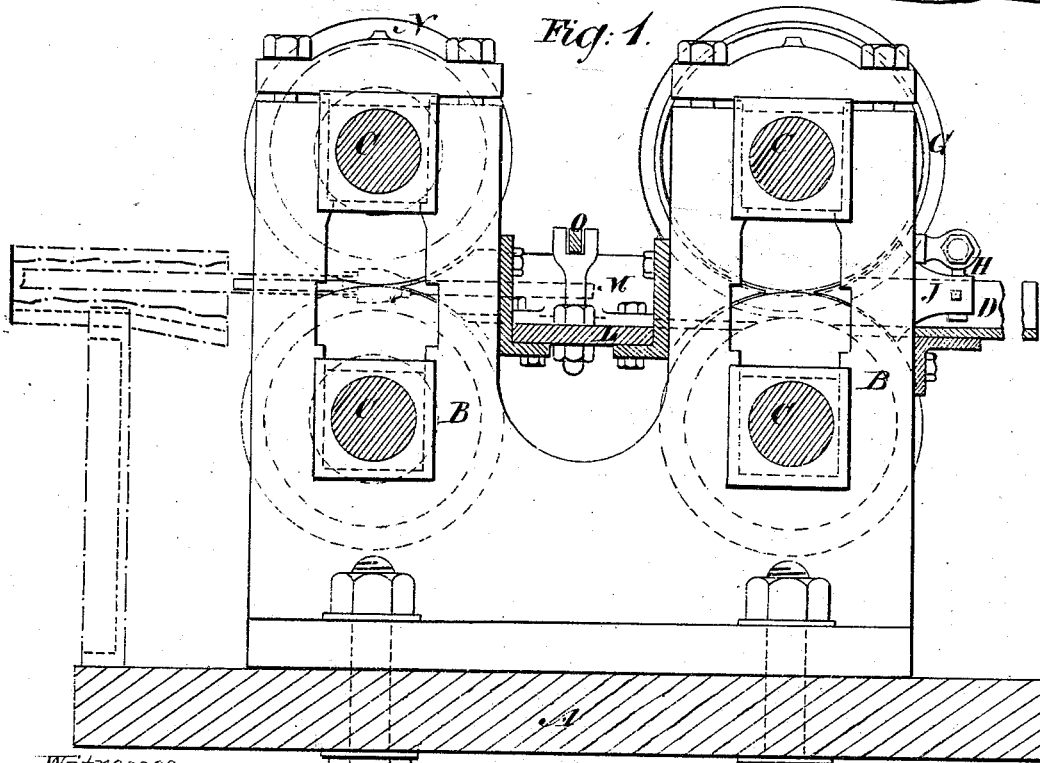
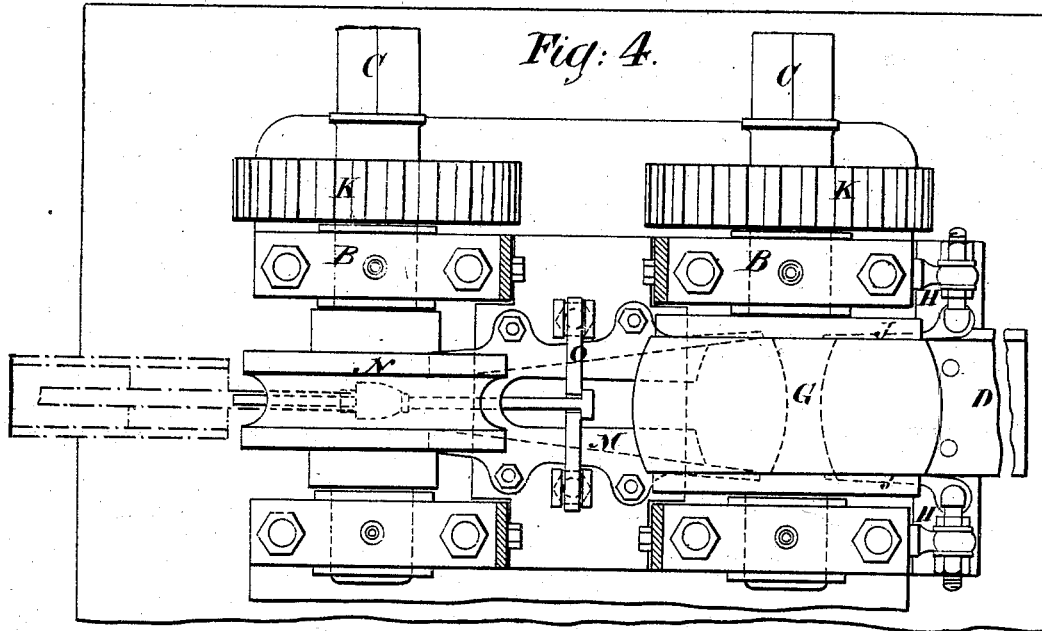

Witnesses  
*Harry King*  
*Baltis & Gougl.*

*G. H. M. Muntz.*

*Inventor.*

*By his Attorney.*

*Wm. W. Baldwin*

G. H. M. MUNTZ.

MACHINES FOR MAKING TUBING.

No. 169,723.

Patented Nov. 9, 1875.

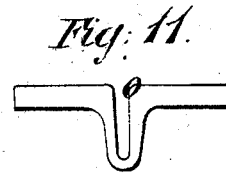
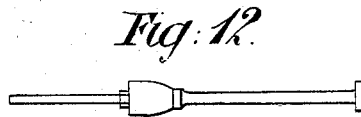
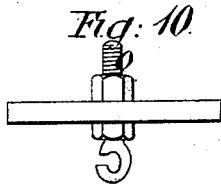
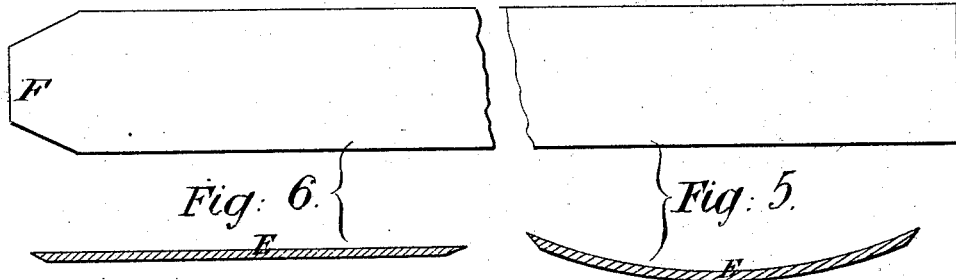
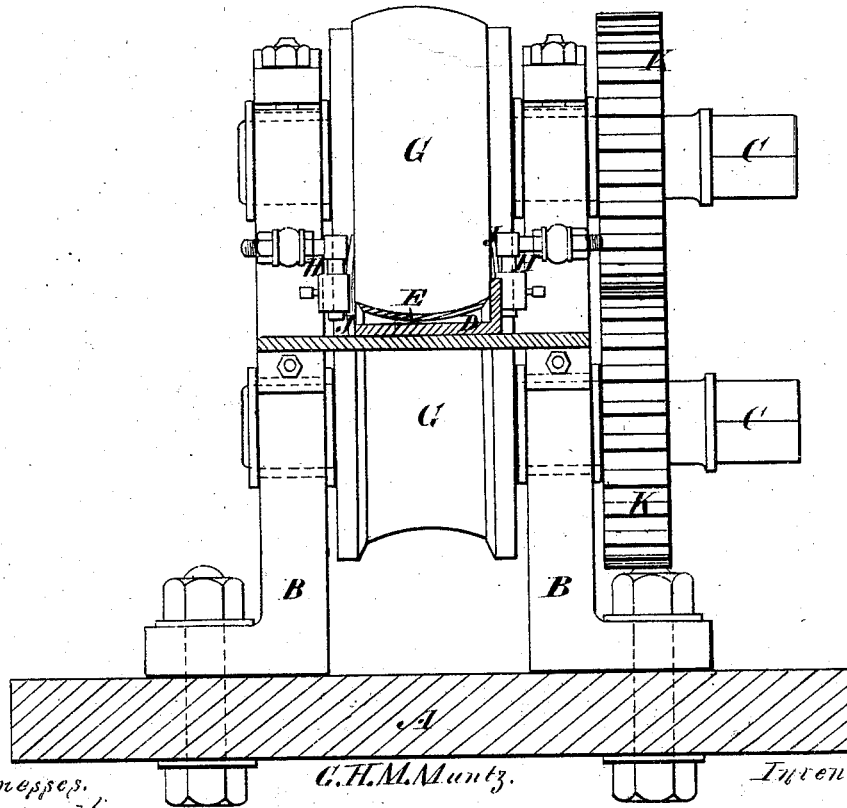

Fig. 2.



Witnesses,  
*Harry King*  
*Charles De Long*

G. H. M. Muntz.

Inventor.

By his Attorney

*Wm. D. Baldwin*

G. H. M. MUNTZ.

MACHINES FOR MAKING TUBING.

No. 169,723.

Patented Nov. 9, 1875.

Fig. 7.

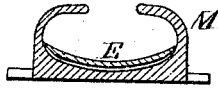

Fig. 8.

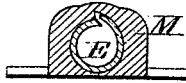

Fig. 9.

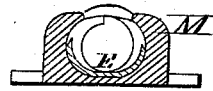
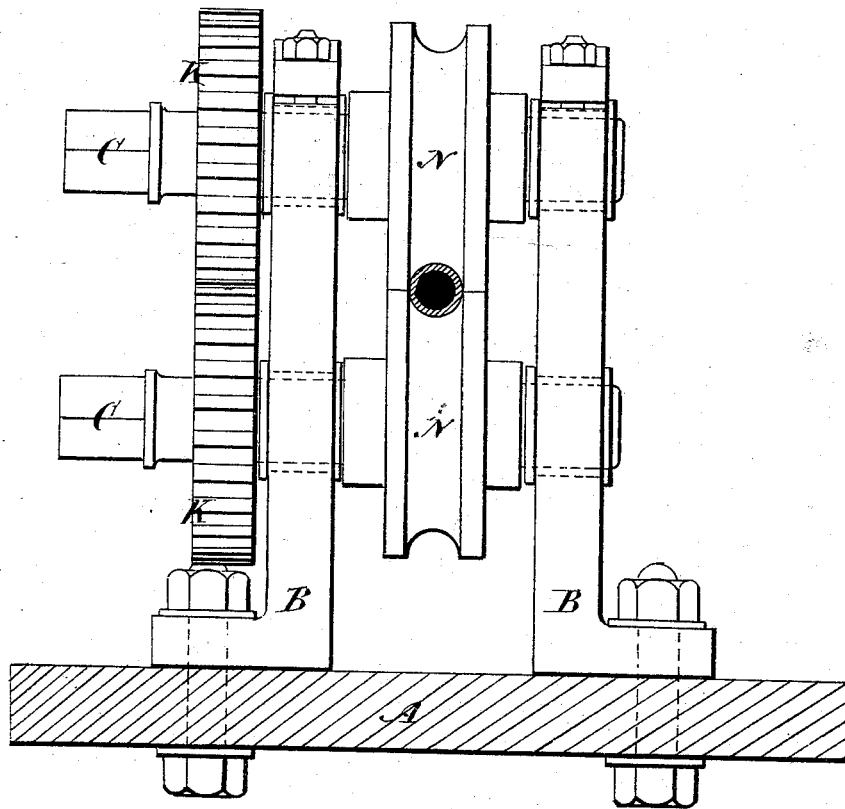

Fig. 3.



Witnesses.  
*Harry King*  
*Charles DeLong*

*G. H. M. Muntz.*

*Inventor.*

*By his Attorney. J. M. Baldwin*

# UNITED STATES PATENT OFFICE.

GEORGE HENRI MARC MUNTZ, OF CHURCH HILL HOUSE, HANDSWORTH,  
ENGLAND.

## IMPROVEMENT IN MACHINES FOR MAKING TUBING.

Specification forming part of Letters Patent No. **169,723**, dated November 9, 1875; application filed  
May 22, 1875.

*To all whom it may concern:*

Be it known that I, GEORGE HENRI MARC MUNTZ, of Church Hill House, Handsworth, in the county of Stafford, England, a subject of the Queen of Great Britain, have invented or discovered new and useful improvements in machinery for the manufacture of lap-welded iron tubes and other tubes, and of skelps for the manufacture of iron tubes and other tubes; and I, the said GEORGE HENRI MARC MUNTZ, do hereby declare the nature of the said invention, and in what manner the same is to be performed, to be particularly described and ascertained in and by the following statement thereof—that is to say—

This invention has for its object improvements in machinery for the manufacture of lap-welded iron tubes and other tubes, and of skelps for the manufacture of iron tubes and other tubes.

For the manufacture of lap-welded iron tubes I take a strip of iron at a welding-heat as it is withdrawn from a heating-furnace, and introduce it through a guide, (which may, if desired, be furnished with friction-rollers,) between a pair of rolls either parallel or convex and concave, and suitably formed on their peripheries, to deliver the strip as it is passed between them with a chamfer or bevel on one or both of its edges. The chamfered or beveled strip as it passes from between these rollers enters another guide, which is so formed as to cause it to bend over the strip until the edges overlap one another, thus forming the skelp or unwelded tube, with a lap or scarf prepared ready for welding. To effect the welding of the skelp, the skelp as it passes from the guide enters between a pair of welding-rolls having suitably-formed grooves around their peripheries. Between the rollers I introduce a mandrel, as usual, and as the skelp passes over it welding-hot, it is delivered from the welding-rolls a lap-welded tube.

If it is desired to produce a skelp lapped, but not welded, all that is necessary is that the strip should not be passed through the machine at a welding-heat, but simply hot enough for the operation of skelping or turning up to be properly performed.

The whole of the guides and rolls above de-

scribed are in one line, and so connected that the unchamfered or unbeveled strip is passed into the first guide, and through the whole of the remaining rolls and guide in one continuous and unbroken course of operation, and is delivered out of the second pair of rolls a lap-welded tube, or unwelded beveled and chamfered skelp, in accordance with the heat employed at the will or choice of the operator. One or more pairs of rolls may be set up after and behind the welding-rolls, for the purpose of reducing the welded tube or unwelded skelp to any given size.

Having thus described the nature of my invention, I will proceed to describe more fully the manner of performing the same.

My said invention has for its object the cheapening and improving of the manufacture of lap-welded iron tubes and other tubes, as also the quicker and cheaper production of skelps for the manufacture of lap-welded iron tubes and other tubes, the same machine being used without change in any of its parts, whether for the production of a welded tube or other tube, or simply a scarfed or beveled and lapped skelp ready for welding in the ordinary way in the manufacture of lap-welded iron or other tubes, the simple difference being this, that, if I desire a lap-welded iron tube or other tube, I pass the strip of iron into the machine at a welding-heat; but if I desire to produce an unwelded skelp I then pass the strip of iron into the same machine at a red heat only, and not at a welding-heat, and thus I produce at my will either an unwelded skelp or welded tube, for the strip of iron enters at one end of the machine a plain strip of iron, and comes out at the other end of the machine a scarfed or beveled unwelded skelp ready for welding in the ordinary way, or a lap-welded tube and in one continuous and unbroken and automatic operation, according to the degree of heat employed at my will.

In the sheets of drawings hereunto annexed I have shown various views of a machine constructed according to my invention.

Figure 1 is a side elevation. Fig. 2 is a front elevation; Fig. 3, back elevation, looking at the welding-rolls. Fig. 4 is a plan view

of the machine; Fig. 5, strip from concave and convex rolls; Fig. 6, strip from straight rolls; Fig. 7, open end of guide M; Fig. 8, closed end of guide M; Fig. 9, cross-section, midway of guide M; Fig. 10, cross-bar with adjusting-screw; Fig. 11, cross-bar without screw; Fig. 12, T-headed rod with mandrel.

I will now proceed to describe the machine shown in the before-mentioned figures, premising that the letters used refer to all similar parts in common throughout the drawings.

A is a strong cast-iron foundation-plate, on which is erected the two standards B B, which receive the brass bearings that carry the roll-spindles C C C. In the front of the machine, Fig. 2, I fix a cast-iron guide-plate, D, one side raised at right angles to its base, but raised on one side only. The raised side of this guide faces the workman when he is entering the strip into the rolls G G. This guide-plate may be fitted with friction-rolls, so as to diminish the contact and friction of the hot strip E while passing over it. The guide-plate D may be made for working on either side of the machine, so as to suit a right-handed or left-handed workman, as the case may be.

H H are supports for the side guides J, one of which guides is placed on the side of standard B nearest to the workman.

The ends of the guides D and J nearest the rolls G G are to be shaped to fit the curvature of the rolls G G accurately.

The first pair of rolls, G G, are the beveling or scarfing rolls. These rolls are fitted on wrought-iron spindles, or the roll and spindle may be cast in one piece. Each spindle has a toothed wheel, K K, fitted onto it, of such a diameter as will gear into one another and drive the pair of rolls. Each spindle has a square part formed on one end of it, for the purpose of receiving the movable coupling-boxes connected with the motive-power employed for driving the machine.

The peripheries of the rolls G G are, by preference, made slightly concave and convex, respectively, or they may be made quite straight, but in either case they are so turned as to produce beveled edges on the strip E as it passes through them, and a section of the strip E taken on its passage through the machine immediately after having passed through the rolls G G, would be formed as shown by Figs. 5 and 6, respectively, according to the form of roll used—viz., either concave and convex or straight.

In the space between the standards B B—that is, between the beveling and the welding rolls N N—I fix a sole-plate, L, to carry the guide M. One end of this guide M is placed close up to the rolls G G, and the other end is nearly as close to the welding-rolls N N.

This guide M is made in two halves in the direction of its length, and is fixed to the sole-plate L by bolts and nuts. That end of the guide nearest the rolls G G must have its open end wide enough to admit the strip E as it

leaves the rolls G G. The end of this guide nearest to the welding-rolls N N must not be open, but the top edges of it must meet close together for part of its length, and this guide must be so formed that the inside of it presents the two sides with an overhanging curvilinear form to each side, gradually approaching a nearly circular form at the end nearest the rolls N N; but the curved shape of one side of this guide must be gradually depressed about one and a half times the thickness of the strip E that has to pass through it, so as to allow that part of the strip which is not so much depressed to lap over as it passes through the end of the guide nearest to the rolls N N, thus forming the skelp or unwelded tube with a beveled or scarfed joint ready for the welding-rolls N N placed immediately before it and ready to receive it on its onward progress through the machine. (See Fig. 7 for open end of the guide; Fig. 8 for closed end; Fig. 9 for cross-section, taken at half the length of the guide.)

The second pair of rolls are the welding-rolls N N, and these rolls are fitted onto spindles C C, having a square formed on one end of each spindle for connection with the motive power, as previously described, and these spindles are provided with toothed wheels similar to K K. These welding-rolls N N are provided with suitably-formed grooves for the respective diameter of the tube to be made, either welded or as an unwelded skelp ready for welding in the ordinary way.

In the space between the standards B B—that is to say, between the beveling and welding rolls—I place a bar, O, transversely carrying an eyebolt open on one side to receive a T-headed ended mandrel rod. This eyebolt is to be screwed and furnished with nuts to raise or lower it as required, (see Fig. 10,) or the cross-bar may be made with a simple slot to receive the T-headed ended mandrel rod, as shown in Fig. 11. This cross-bar is supported on uprights fitted to the sole-plate L.

The T-headed ended rod, Fig. 12, is made to carry the mandrel used in the manufacture of lap-welded iron tubes and other tubes, and when made and used as shown at Fig. 11, it is inserted from the elevation, Fig. 3, and so dispensing with the long stem bar for the most part now in use; but this stem-bar with its accompanying trough can be used at the will of the user.

Carrying the mandrel by supporting its rod in an open support affords great facility for adjusting its position and for removing it or putting it in place.

In practice I find it advisable to use rolls of about two feet in diameter; but I do not confine myself to any particular diameter of roll, either above or below two feet in diameter.

In fixing the speed of the rolls G G it is necessary that the rolls N N should be driven faster than the rolls G G, so that the elongation of the iron caused by the action of the welding-rolls may be passed through the weld-

ing-rolls at a speed slightly in excess of the respective degree of elongation allowed for by the diameter of the respective mandrel used in the welding-rolls.

The end of the strip E which first enters the rolls G G should have the corners cut off, as at F.

Having thus described the nature of my invention and the manner of performing the same, I would state that I do not bind or confine myself to the precise details and arrangements I have here described, as variations in detail may be made without departing from the main features of my invention; but

What I claim is—

1. The combination of beveling and scarfing

rolls G G, bending-guide M, and rolls N, driven at a quicker surface-speed than the rolls G and with a mandrel between them, substantially as herein described.

2. The combination of guides D J, beveling and scarfing rolls G G, bending-guide M, and rolls N driven at a quicker surface-speed than the rolls G and with a mandrel between them, substantially as herein described.

GEORGE HENRI MARC MUNTZ.

Witnesses:

FRAS. HY. FISHER,

THOMAS COOKE,

*Clerks to Mr. Robert Harding Milward, Notary Public, 41 Waterloo street, Birmingham, England.*