

W. NEVINS.  
SEED-PLANTER.

No. 169,725.

Patented Nov. 9, 1875.

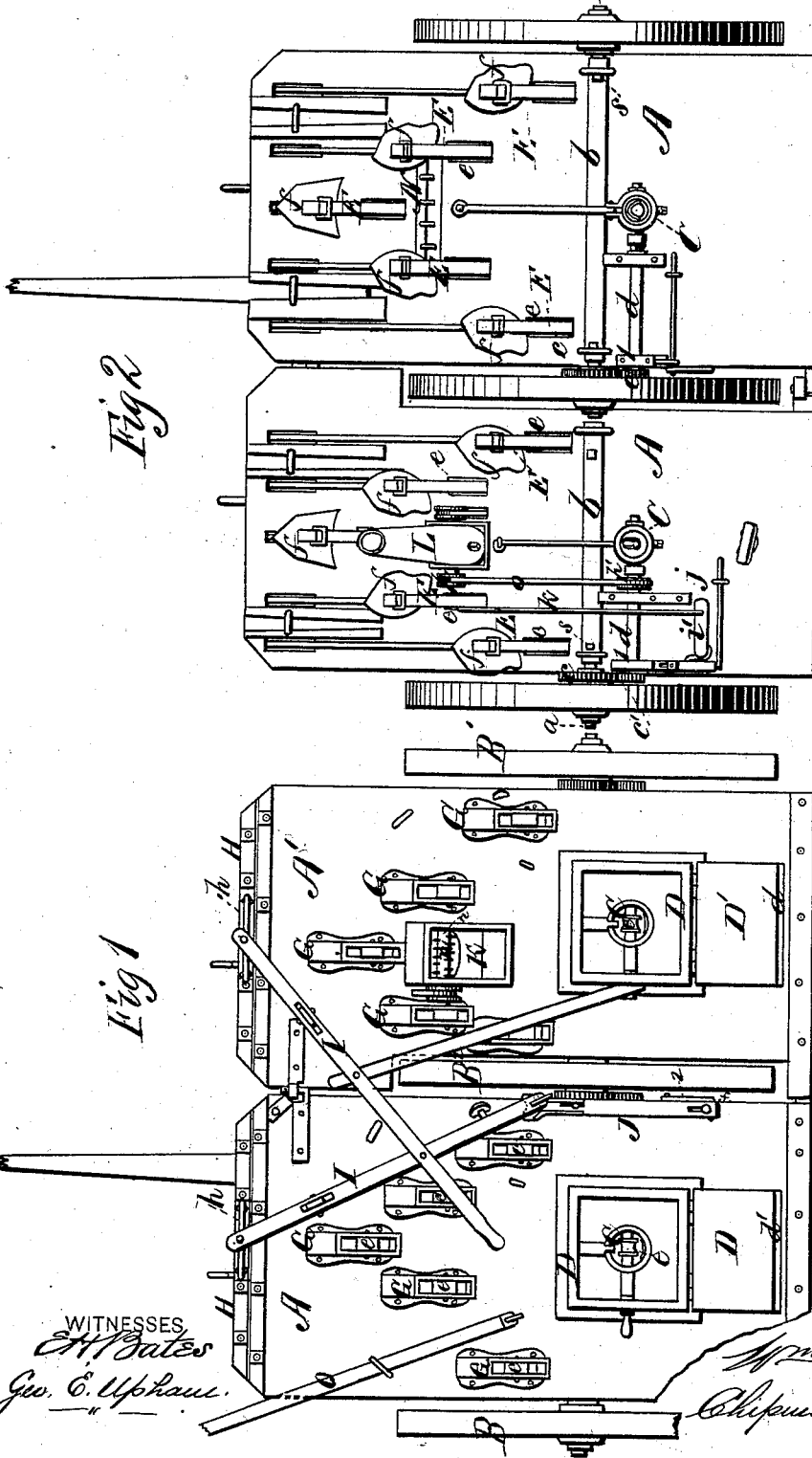

W. NEVINS.  
SEED-PLANTER.

No. 169,725.

Patented Nov. 9, 1875.

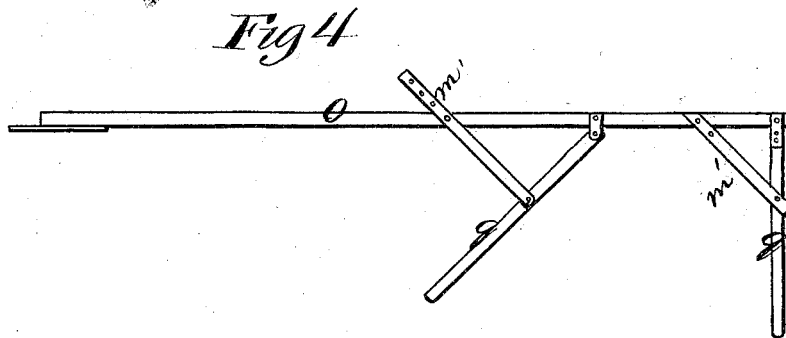
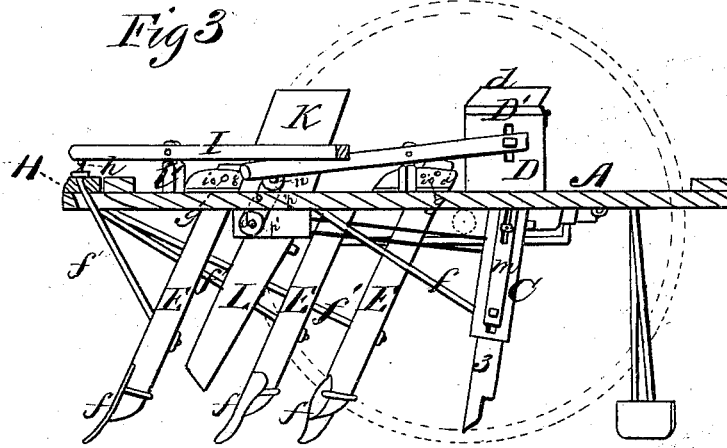

WITNESSES

*George C. Upham,*  
*Matth. C. Masi*

INVENTOR

*Wm. Nevins,*  
*Chipman & Saunders Co.,*  
ATTORNEYS

W. NEVINS.  
SEED-PLANTER.

No. 169,725.

Patented Nov. 9, 1875.

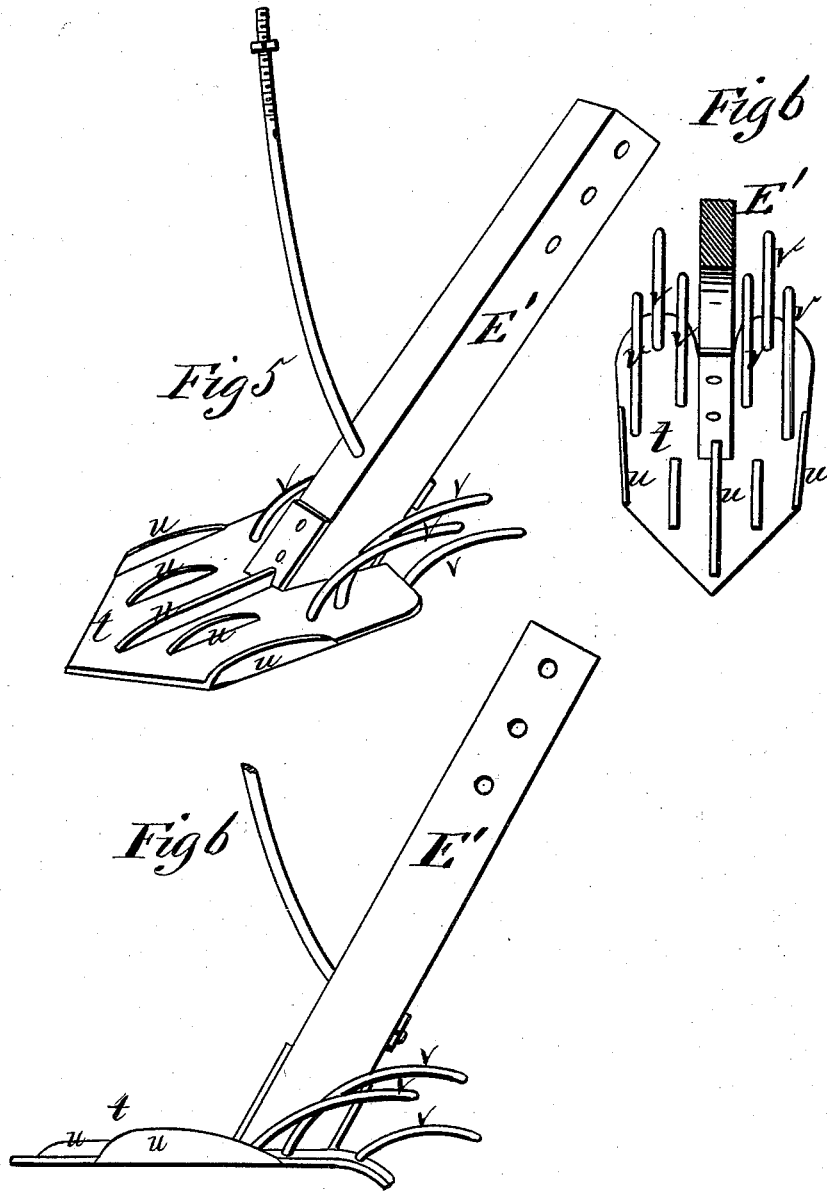

WITNESSES  
*E. H. Bates*  
*George E. Uphaus*

INVENTOR  
*Wm. Nevins*  
*Chipman & Co.*  
ATTORNEYS

# UNITED STATES PATENT OFFICE.

WILLIAM NEVINS, OF TITUSVILLE, PENNSYLVANIA.

## IMPROVEMENT IN SEED-PLANTERS.

Specification forming part of Letters Patent No. **169,725**, dated November 9, 1875; application filed July 3, 1875.

*To all whom it may concern:*

Be it known that I, WILLIAM NEVINS, of Titusville, in the county of Crawford and State of Pennsylvania, have invented a new and valuable Improvement in Machines for Planting Corn, Beans, &c.; and I do hereby declare that the following is a full, clear, and exact description of the construction and operation of the same, reference being had to the annexed drawings making a part of this specification, and to the letters and figures of reference marked thereon.

Figures 1 and 2 of the drawings are representations of plan views of my planting-machine, and Figs. 3, 4, 5, and 6 are detail views of the same.

This invention has relation to improvements in machines for planting, hoeing, and digging potatoes, and which are also adapted to planting corn, beans, and the like; and the nature of the invention consists in the arrangement and novel construction of the various devices employed, as will be hereinafter more fully explained and claimed.

In the annexed drawings, A A' designate two platforms of rectangular form, which are detachably hinged together, and when attached to each other are supported upon two lateral transporting-wheels, B B', and an intermediate wheel, B<sup>2</sup>; but when separated for a purpose hereinafter explained, a fourth wheel will be secured to that platform which will then only have one. The spindles *a* of all these wheels are inserted into a tube, *b*, rigidly gripped by any suitable means to the under side of the said platform, and are held against undue displacement by means of a set-screw, *s*. By this means the wheels are made laterally adjustable to or from the platform, and thus their distance apart may be increased or diminished in accordance to the various distances apart of the rows. *c* represent gear-wheels, which are adjustably secured to the hub of wheels B B', and engage with a pinion, *c'*, keyed upon the end of a shaft, *d*, having its bearings on the under side of the said platform, and passing inward through a drop-spout, C, or terminating therewith and connected by means of a suitable coupling with a seed-dropper, *e*, arranged therein by means of which seeds deposited in a hopper,

D, on the upper side of the said platform will be allowed to fall through drop-spout C into a furrow formed for their reception, by means hereinafter described. Hoppers D are provided with hinged lids D', which are converted into drivers' seats by means of side and back flanges *d'*, one of these seats thus formed being on each platform in order that when separately used they may be provided with this convenience. *e* represent slots, which are arranged parallel to each other, and are inclined downwardly from rear to front. They are also arranged in diverging lines from the front to rear, and are provided with sockets G, which continue the backward inclination of the said slots, and are provided with a number of spaced perforations, *i*, by means of which shovel-standards E passed upward through the said slots into the sockets are adjusted to give a greater or less pitch to the shovels *f* detachably secured upon their ends. This may be done by removing a pin, *g*, by means of which standards F are secured to castings or sockets G, and replacing it in a perforation to one side, or above or below that formerly used, as the necessities of the case may require.

The shovels *f* may be raised from the surface of the ground simultaneously by means of metallic rods *f'*, which are secured to standards E, pass thence upward through the front edges of platforms A A', and are suitably secured to a head-bar, H, which latter is provided with a bail, *h*, by means of which it is attached to, and operated by, a vertically-vibrating lever, I, having its fulcrum in an upright, *l*, erected on the said platform. When the power end of this lever is thrust down the shovels will be evenly and simultaneously raised from the surface of the ground, and this operation is made to disconnect the seed-droppers in the spouts in the following manner, to wit: The outer bearings *l* of shafts *d* are endwise movable, and they are drawn away from the gear on the hub of the outer transporting-wheels by means of a lever, *j*, pivoted to the platforms at *i'*, one end of which lever is secured to the said movable bearing, and the other end thereof connected, by means of a rod, *k*, to one of standards E. Hence, when the cultivator teeth or shovels

are raised, either for the purpose of conveniently driving from the field, or in passing an obstruction, the operation of the seed-droppers in the spouts will be suspended, and the seed prevented from being wasted during such elevation.

Instead of the above, the bearings being movable, as described, I may elect to use the following for the accomplishment of the same end: The bearings are each connected by means of a rod, 2, with an endwise-movable and suitably-guided bar, J, on the upper side of the platform, the front edge of which is notched, as shown in dotted lines, Fig. 1, for the purpose of receiving the rear end of lever I, by means of which the shovel-standards E are raised. When the rear end of this lever is thrust forcibly down it will raise the shovels, at the same time forcing bar J backward, and throwing the pinion *c'* on shaft *d* out of gear with the operating device on the wheel.

Dropper-spouts C may also be raised by means of a rod, *m*, extending upward within reach of the driver, and secured to a supplemental spout, 3, arranged within, and endwise movable in relation to the spout proper.

When the planter is double, as shown in the drawings, Fig. 1, one of its sections may be converted into a potato-planter by removing one of the spouts, and attaching in its place, or under a hopper, K, provided for the purpose, an enlarged spout, L, within which a spurred shaft, *n*, finds its bearings. Motion is communicated to this shaft by means of an endless belt, *o*, passing over a pulley-wheel, *p* and *p'*, respectively, on shafts *n* and *d*, as shown in Fig. 3. By this means corn and potatoes may be planted in alternate rows.

I sometimes, with a view to breaking up the clods more effectually before the seed is dropped into a furrow, and to destroying the

small weeds among the plants the first hoeing, apply a rake, N, to the first pair of standards E, but it is not a permanency, and will be used or not, according to the exigencies of the case. I also use a marker, O, having double arms *q q'*, which are adjustable to or from each other, for the purpose of marking off the rows at a greater or less distance apart.

Standards E, being detachable, may be removed from platforms A A', and the latter converted into a potato-digger by substituting in lieu thereof standards E', bearing on their lower ends flat metallic shovel-plates *t*, which are provided upon their upper front horizontal surfaces with longitudinal ridges *u*, for breaking the continuity of the sods or earth-crust as it is raised by the shovel, and with wire fingers *v*, extending rearwardly a certain distance beyond the shovel, for the purpose of allowing the broken earth to sift through, and the potatoes to fall on the surface of the soil.

What I claim as new, and desire to secure by Letters Patent, is—

1. The adjustable shovel-standards E, pivoted in sockets G, attached to the platform, in combination with the rods *f'*, head H, bails *h h*, and levers I I, having their fulcra in upright standards on the platform, substantially as described, and for the purpose set forth.

2. The perforated cast-metal socket G, in combination with the perforated standard E and rods *f'*, substantially as described, and for the purpose set forth.

In testimony that I claim the above I have hereunto subscribed my name in the presence of two witnesses.

WILLIAM NEVINS.

Witnesses:

L. W. WILCOX,  
J. R. LUSE.