

T. VAN KANNEL & L. D. TOWSLEY.

COMBINED PRESSURE-GAGE AND HEAT REGULATOR.

No. 169,745.

Patented Nov. 9, 1875.

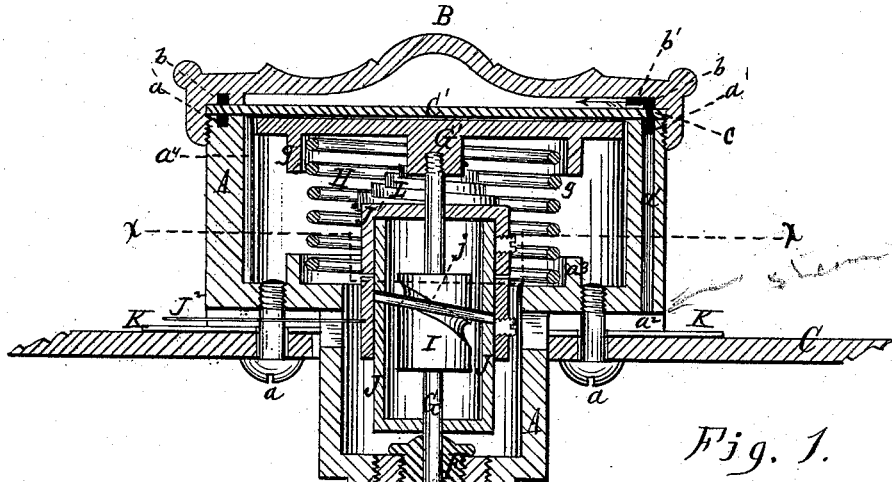

Fig. 1.

Gas Inlet

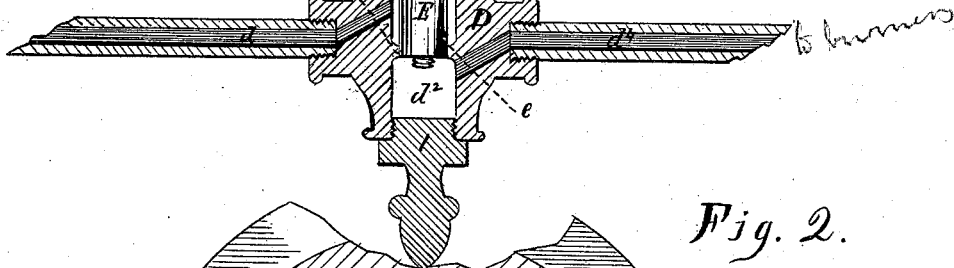
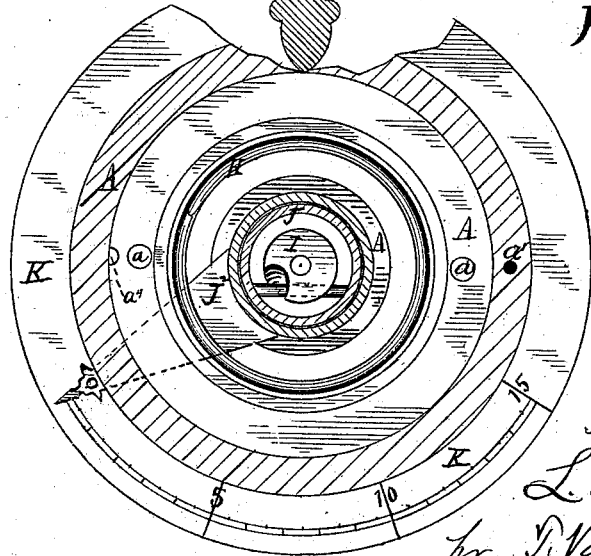

Fig. 2.



Attest.
H. Stewart
S. Prehn

Inventors
T. Van Kannel
L. D. Towsley
pr. T. Van Kannel
atty.

UNITED STATES PATENT OFFICE.

THEOPHILUS VAN KANNEL AND LOVIAS D. TOWSLEY, OF CINCINNATI,
OHIO; SAID VAN KANNEL ASSIGNOR TO SAID TOWSLEY.

IMPROVEMENT IN COMBINED PRESSURE-GAGES AND HEAT-REGULATORS.

Specification forming part of Letters Patent No. **169,745**, dated November 9, 1875; application filed August 31, 1875.

To all whom it may concern:

Be it known that we, THEOPHILUS VAN KANNEL and L. D. TOWSLEY, both of Cincinnati, Hamilton county, State of Ohio, have invented a new and Improved Combined Pressure-Gage and Heat-Regulator; and we do hereby declare that the following is a full, clear, and exact description of the same, reference being had to the annexed drawings, making a part of this specification.

Figure 1 is a vertical section, and Fig. 2 a horizontal section taken in the line *x* of Fig. 1.

The nature of our invention relates to a pressure-gage and heat-regulator used in gas-machines or for other purposes, wherein light hydrocarbons, such as gasoline, are made use of, which is brought to a vapor under high pressure by heat from the gas generated, and the action of the regulating device of our invention depends on the water or steam pressure of the retort.

The construction of our invention is as follows: A is the main frame, which is surmounted by a cap, B, all held to the bed-plate C of the machine, or any other permanent part, by two machine-screws, *a a*.

The gas cut-off consists of the cross-piece D, one end being screwed into part A, which is its fastening. At *d* is the inlet of gas from the gas-holder, which finds its way into cavity *d*¹; its only means of escape is to cavity *d*² through the wedge-shaped notch *e* cut into plug E. This plug fits snugly the narrow neck dividing the cavities *d*¹ and *d*². The outlet is through the pipe *d*³, which then leads to the burners which supply the heat to the retort. A stuffing-box, F, surrounding the stem G, which operates the cut-off E, prevents the gas escaping at that point.

At the top of the structure is seen a diaphragm, C', made of any suitable pliable material, as leather, rubber packing, or metals. This is placed between the face of part A and the cap B, so that when the latter is screwed down on the former the diaphragm is firmly held in place, making the space above the diaphragm water or steam tight. Grooves *a* and *b* are cut in parts A and B, and a hole is punched into the diaphragm in such a position as to bring it just between the grooves *a* and *b*.

A communication is made between groove *b* and the steam-space by a small perforation, *b'*. A small hole, *a'*, is also bored through the side of the part A, to which is connected, at *a*², a pipe, by a union which leads to the steam or water vessel in the retort.

Just below the diaphragm is the movable disk G', which takes the strain put on the diaphragm, and is kept in equilibrium by a strong coil-spring, H, which reacts against the bottom of frame A. Flanges *g* and *a*³ keep the spring in position. The disk G' is kept from rotating by a notch in its periphery, which engages with a corresponding vertical bead, *a*⁴, in the interior of part A.

The device herein used for indicating the steam-pressure consists of the spiral I, which is permanently attached to stem G, which connects the cut-off E and disk G'. Around the spiral is placed a rotating sleeve, J, having a bearing on the round-headed stuffing-box F at one end, and surmounted by a cap, J¹. A cross-pin, *j*, in sleeve J coincides with the groove in spiral I.

L is a coiled spring, having one end attached to the disk G' and the other to cap J¹. This spring is so arranged as to take up all the loose motion of the spiral I and its attachment to the sleeve J.

The index J² is fastened to sleeve J by a set-screw, and is brought out through a slot cut in frame A, pointing over dial K, which is graduated in accordance with the pressure indicated.

The operation of our invention is as follows: The communication to the passage *a*¹ being made to the water or steam space in the retort, this pressure, as it increases, presses down the diaphragm, and it, in turn, presses on the disk G', which has a free vertical movement only. This vertical movement causes a rotary movement of the sleeve J, and by the attachment to it of the index J² over the dial K. This indicates the amount of pressure per square inch on the diaphragm at all times. The stem G then passes through the stuffing-box F, and gives to the cut-off E a vertical reciprocating motion equal to the disk G'. The farther the cut-off is depressed the narrower will be the passage-way for the gas which passes through the wedge-shaped notch *e*. When no press-

ure of steam is on the diaphragm, the plug being at the uppermost point, as shown in drawing, it permits a full flow of gas, sufficient to supply the burners under the retort; but on the pressure increasing, the diaphragm, lowering, gradually narrows the passage-way between the neck d^5 and the notch e , partly cutting off the gas, thus reducing the heat. The size of the lights under the retort may also be made to retain a uniformly higher or lower heat by screwing the plug farther up or down on the stem, as is obvious by the construction above given. The pressure in retort can thus be kept at any desired degree.

The notch e extends from the top to the bottom of the cut-off E, so that the light will not be extinguished, even when no gas is burned for illuminating purposes. By this arrangement the retort will always be in readiness to furnish the vapor necessary to supply its full capacity of gas.

Having thus described our invention, what we claim as new, and desire to secure by Letters Patent, is—

1. The frame A, provided with the cap B and the groove a^1 , communicating with the groove b , in combination with the diaphragm C', having the perforation c , substantially as and for the purpose hereinbefore described and set forth.

2. The combination and arrangement of the disk G', stem G, spiral I, engaging the sleeve J through the pin j , the index J², dial K, and spring L, substantially as and for the purpose described.

3. The stem G, with adjustable cut-off E, wedge-shaped notch e , in combination with the neck d^5 , constituting the regulating device for the supply of gas to the heating-burners, as herein described.

4. The combination of the pressure-gage herein described with the cut-off E, substantially as herein described and set forth.

T. VAN KANNEL.
L. D. TOWSLEY.

Attest:

A. V. STEWART,
L. PREHN.