

M. ALISSOFF.
TYPE-WRITING MACHINE.

No. 169,757.

Patented Nov. 9, 1875.

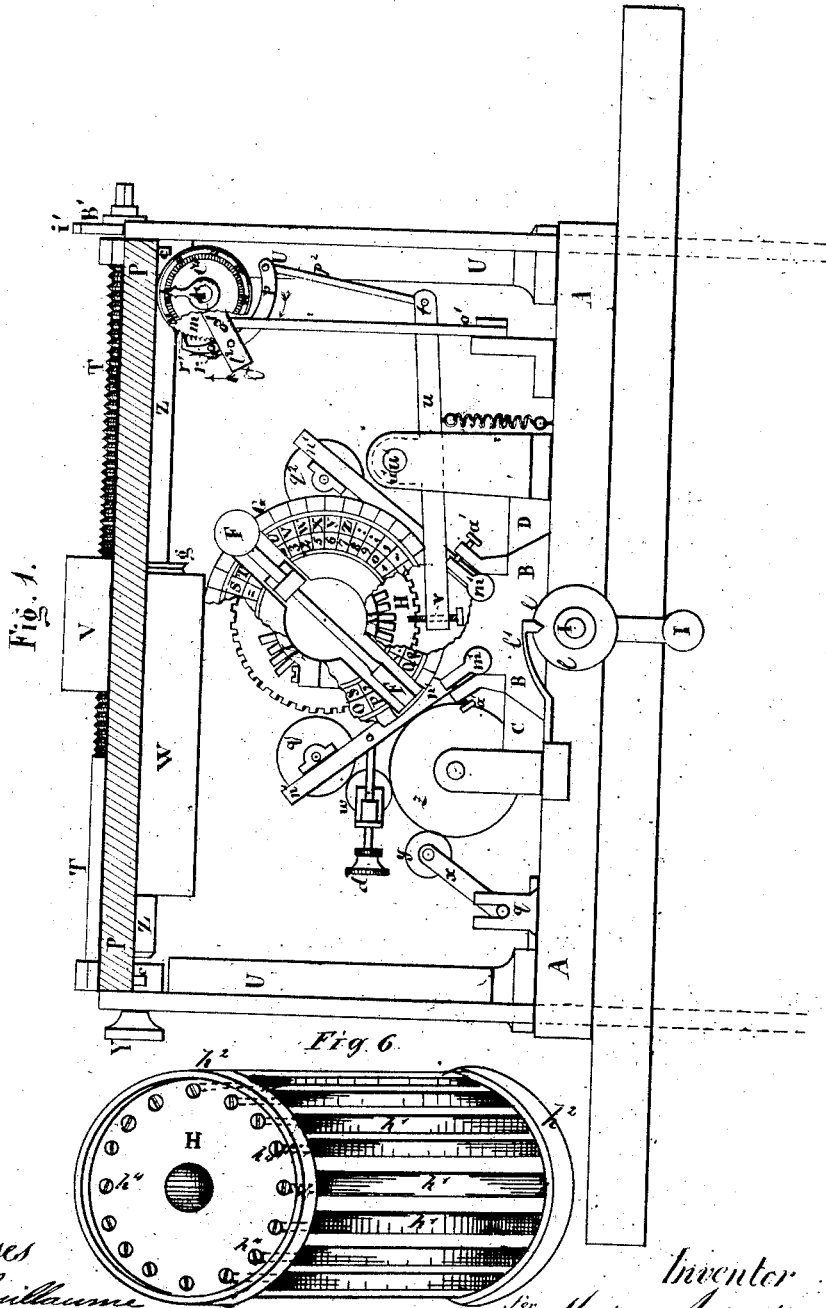

Witnesses
Henri Guillaume
Charles Jacobsen

Inventor
for Michael Alissoff
by Henry Orth
attorney

M. ALISSOFF.
TYPE-WRITING MACHINE.

No. 169,757.

Patented Nov. 9, 1875.

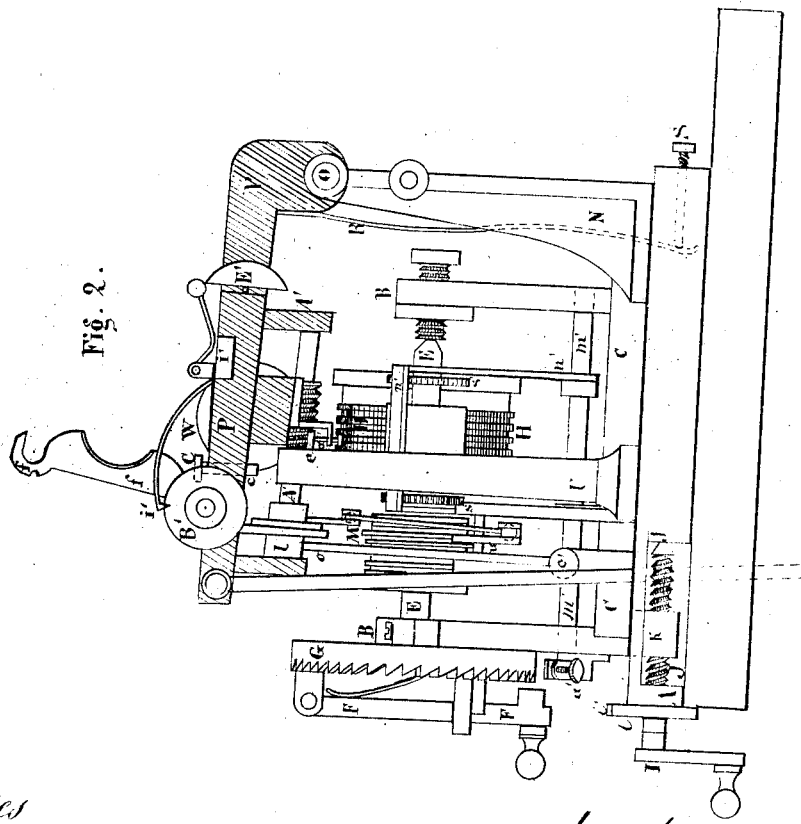
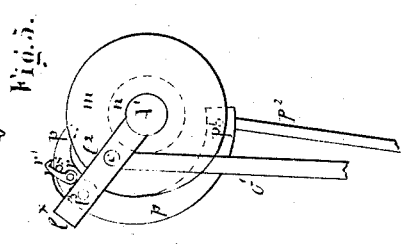
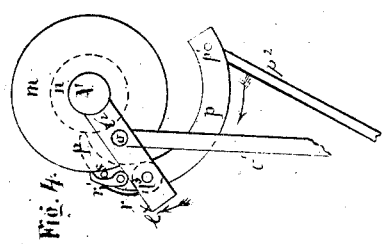

Witnesses
Henri Guillaume
Chas. Jacobsen

Inventor
 for *Michael Alisoff*
Henry C. Pitt
 attorney

M. ALISSOFF.
TYPE-WRITING MACHINE.

No. 169,757.

Patented Nov. 9, 1875.

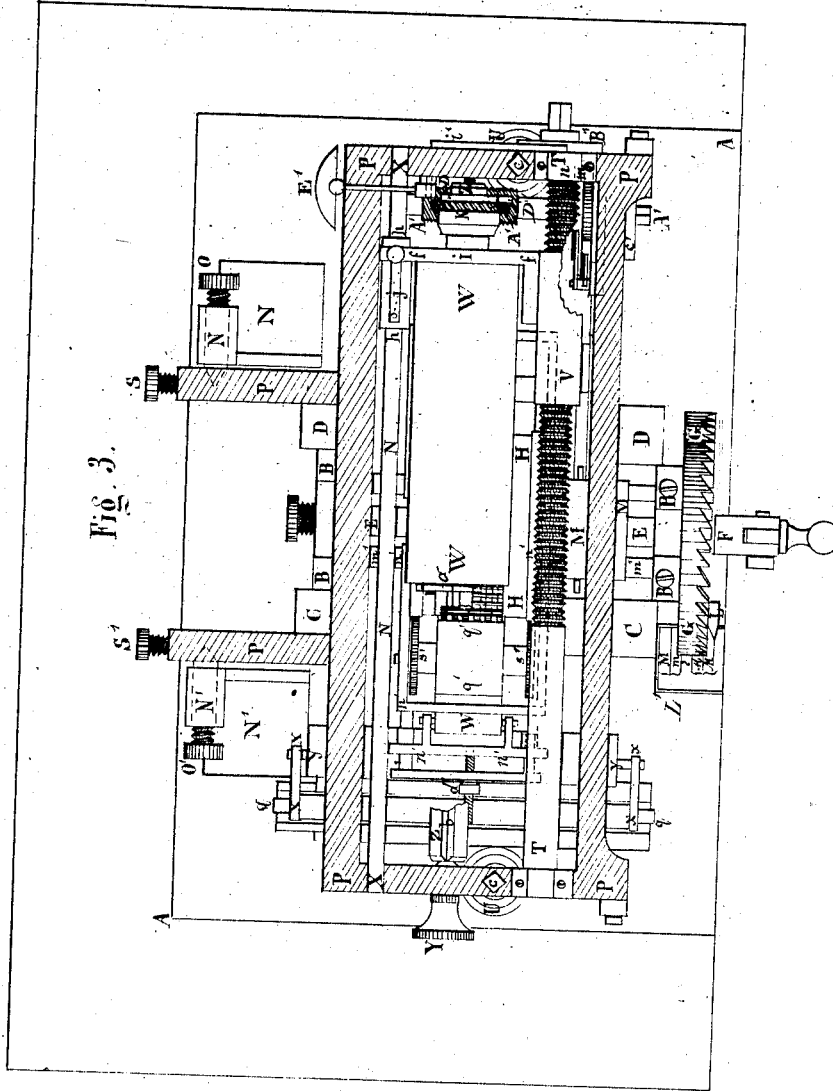

Fig. 3.

Witnesses:
Henri Guillaume
Chas. Jacobsen

Inventor:
for Michael Alissoff
for Henry Orth
attorneys

M. ALISSOFF.
TYPE-WRITING MACHINE.

No. 169,757.

Patented Nov. 9, 1875.

Fig. 9.

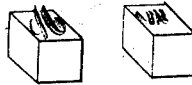

Fig. 8.

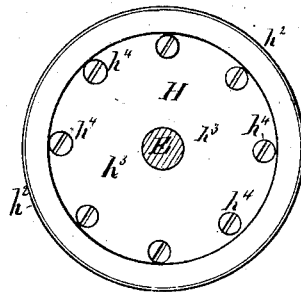
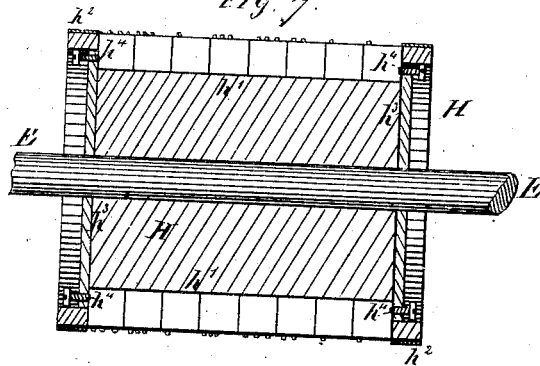

Fig. 7.



Witnesses.
Henri Guillaume
G. Prentiss

Inventor
Michael Alisoff
Henry Curtis

UNITED STATES PATENT OFFICE.

MICHAEL ALISSOFF, OF ST. PETERSBURG, RUSSIA.

IMPROVEMENT IN TYPE-WRITING MACHINES.

Specification forming part of Letters Patent No. 169,757, dated November 9, 1875; application filed April 19, 1875.

To all whom it may concern:

Be it known that I, MICHAEL ALISSOFF, of St. Petersburg, Russia, have invented an Improved Printing Apparatus, called "Typolithograph," of which the following is a specification:

The apparatus invented by me, and called "Fast Printer," is represented in the drawings annexed to this specification.

The like parts are marked in all the drawings with the same letters.

Figure 1 is a front elevation, Fig. 2 a side elevation, and Fig. 3 a plan, all partly in section, of an apparatus constructed according to my invention. Figs. 4 and 5 are detail views of the spacing mechanism. Figs. 6, 7, and 8 are similar views of the type cylinder or drum H, showing its construction and arrangement in relation to the types; and Fig. 9 is a perspective view, showing the construction of the type as used with my apparatus.

The whole apparatus consists, principally, in the following three separate parts: First, the moving slide, (carriage,) carrying the axle with the drum, into which the type is set. Second, a rocking frame into which is fixed the cylinder, with the paper to be printed rolled around. On the same frame is placed the mechanism for turning the cylinder more or less, in proportion to the size of type to be printed. Third, the ink-distributing mechanism.

In order to be more explicit, we shall describe each of these parts separately.

1. *The slide, (carriage.)*—In the middle of a cast-iron plate, A A A A, fixed on a small wooden table, moves to and fro the slide B B B B, between two grooves, C C and D D. The slide B B supports the axle E E, the fore part of which has a handle, F F, for turning the axle E E to the one or the other side. The handle turns round the dial-plate, on which the letters are indicated, exactly in the same manner as in telegraph apparatus of former systems with dial-plates. On the axle E E is immovably fixed the metallic drum H H, on the surface whereof are cut, in parallel direction with the axle, channels or grooves *h*, all around the drum, and at equal distance from each other. The number of these grooves is equal to the number of teeth of the dial-plate.

The drum or cylinder H is further provided on either end with slightly-projecting rims *h*², covered with india-rubber or leather, or other like adhesive material, for the purposes hereinafter more fully explained.

The drum is fixed on the axle in such manner that, when the handle F F is stopped opposite one of the letters on the dial-plate, and pressed against the tooth corresponding to that letter, the corresponding groove of the drum with the same letter is on the uppermost part of the drum, and at the same time exactly on the point of contact with the cylinder W W, around which the paper is rolled. If at that moment the cylinder is pressed against the drum, there will be obtained on the paper an impression of the same letter opposite which the handle F F was stopped.

To either side of the drum are screwed flat rings *h*³, covering the ends of grooves. Through the rings *h*³ screws *h*⁴ are penetrating into each of the grooves, by means whereof the type set in these grooves are compressed, and thus fixed in the drum.

The type ordinarily used in printing-offices are not adapted for our apparatus. The whole difference, however, is merely that all type destined for the apparatus has the same body for all letters—*i. e.*, all letters have the form of square prisms of equal size for broad letters as well as for narrow ones—while with the ordinary printing-type the width of the body depends on the width of the letter it bears.

Here is to be observed that in our type the letter is not placed in the middle of the eye, but on the edge to the left, in consequence whereof a broad letter will occupy the whole eye, while a narrow one is placed on the edge to the left.

The apparatus can be adapted for printing with one or with several different types. In either case the dial-plate G G bears an alphabet, with the marks of punctuation, in a circle; but in the latter case there is under each letter a figure or a typographical mark.

The type is placed into the apparatus in the following manner: The handle is stopped opposite any one of the letters shown on the dial-plate, then pressed against the tooth, and

hereupon the type is set into the uppermost groove of the drum in the following order: At first is placed the initial, hereafter the figure or mark of the same type, and then into the same groove the same letter of the other type in the same order. The letters are separated from each other by spaces of equal size, and the type with the spaces in the same groove are compressed by the aforementioned screw penetrating into the groove. The following grooves are filled with type and marks in the same order, whereby all initials of one type will be placed in form of the first circle around the drum. The second ring will consist in small letters, &c.

In an apparatus adapted for printing with two different types, the type is set into the grooves of the drum. The line may be cast so as to form one piece, instead of consisting in separate parts, which would considerably facilitate the placing of type into the apparatus. The type may likewise be cast of ordinary type-metal, or made by galvanoplastic. In order to understand by what means it is obtained that by the drums touching the cylinder only one letter or mark is printed on the paper, although each groove contains several letters and marks, it is necessary to observe that the axes of the drum and cylinder are placed vertically to each other; and as two convex surfaces in such position can touch each other only in one place, it is evident that only that letter will be printed which is at the point of contact of the cylinder and the drum. Above is explained how, by aid of the handle F F turning round the dial-plate G G, the one or other letter of the same type, being on the same level in vertical position to the axle of the drum, is placed under the cylinder. The changing of type is performed by aid of another handle, I, fixed to the fore part of the screw J J. This screw passes through the nut K, Fig. 2, which is fixed underneath to the slide B B. By turning this screw in the one or the other direction, the slide is moved forward and backward. The distance between the turns of the screw is equal to the spaces separating the letters in the grooves of the drum, and, consequently, if, for instance, after printing an initial one wishes to print small letters, it is required to give a full turn to the handle I. For printing an initial after a figure of the same type it is necessary to give two full turns backward, &c. The indicator L, Fig. 3, fixed in front to the slide, and moving along with the same, points out with its end on an immovable scale, L', what sort of type, and whether initials, small letters, or figures, are printed by the apparatus. At the end of the screw I I, Figs. 1 and 2, is fixed a metallic disk, l, with a notch, into which enters the button of a spring, U. This spring keeps the slide in the same position, and prevents its spontaneous motion while it is in action. The snapping of the spring at the notch facilitates counting the

turns given to the screw. On the axle E E is fixed, beside the drum for type, a muff, M M, into which, instead of type, are set pins of different length. Each letter in the drum H H has a corresponding pin on the muff M M. The greater the width of the letter the shorter the corresponding pin, and, vice versa, the narrower the letter the longer the corresponding pin. The action of these pins causes each letter in the line printed to occupy exactly the room required by its width. The manner in which these pins are acting in the apparatus shall be hereinafter fully explained.

2. *The rocking frame.*—Upon the metallic plate, serving as basis to the apparatus, are fixed two supports, N and N'. Through these supports are passing two screws, O and O', with pointed ends, entering into the pan corresponding to each screw, and placed on the frame P P P P. These screws serve like an axle, whereon the frame is rocking. On the hind part of the frame are two cross-bars, whereon the screws O and O' are resting. On each of these cross-bars is fixed a steel spring. Fig. 2 shows only one of these springs, R R. Being more or less compressed by means of the screws S and S', these springs are constantly lifting up the fore part of the frame P P. Thus the frame, when pressed down and left alone, rises again through the action of the springs. For preventing the frame going down lower than required for the regular action of the apparatus, two screws, C and C', pass through the frame on either side. These screws strike with their lower ends on the columns U and U, fastened to the foundation-plate of the apparatus; consequently the frame will go down until the screws C and C' come into contact with the columns; and, further, in order to prevent the frame, by the action of the springs, to rise higher than required, there are fastened to the lower part of the frame two fixed arms, with screws d', one on either side. In Fig. 2 only one of these arms, with the screw d', is visible. The screw d' strikes with its end on the pin e, fixed to the column u. In this manner the stroke of the frame can be increased and diminished by aid of the screws e and d. Into the frame P P is set the axle Z Z, on which the cylinder W W is placed. This axle, with the cylinder, is taken out of the apparatus whenever it is necessary to roll around the same the paper destined for printing.

For taking this axle out of the apparatus it is required to loosen the screw Y on the left of the frame P P. The cylinder W W moves on the axle Z Z forward and backward. To make the cylinder turn together with the axle, this axle has lengthwise a groove or incision, b b, Fig. 3, into which enters a hook, a, fastened to the cylinder and pressed from above by a spring. In parallel direction with the axle Z Z on the frame reposes in pause the screw T T, with the nut V V. This screw is destined to prevent the cylinder from stirring

from its place while turning together with the axle when the apparatus is working, and, besides, to render it possible, after finishing each line, to move the cylinder forward to a certain distance. For this purpose, to the nut V V is fastened a hook, *ff*, which, lowering, catches a corresponding notch in the end of the cylinder. This notch is shown in Fig. 1 and marked *g*. The hook *ff*, after catching the cylinder with the paper, must at the same time with its end clasp the tube *hh*, moving freely on the rod N N, Fig. 3. To the tube *hh* is fastened a spring, turning round the point *j*. After lowering the hook *ff* and its clasping the tube *hh*, the spring *j* is turned until it comes to the hook and presses the same close to the tube *hh*, and at the same time to the cylinder. After finishing a line, it is required to commence a new one, to move the cylinder to the right, which is effected by applying a key to the right-hand end of the screw T T, and giving it one or more turns, considering the space desired between the lines. By turning the screw T T, the nut *vv* will be moved to the right, and consequently the cylinder W W will move along with the nut. To the right-hand end of the screw is fastened, likewise, and turning together with the screw T T, a disk, B', having a small notch, into which enters the button of the spring *vv*. This spring prevents the screws turning spontaneously in one or the other direction during the work, and the snapping of the spring-button facilitates counting the turns given to the screw in changing the lines. On the axle Z Z is fastened to the right-hand end a pinion, K, the teeth whereof catch the endless screw A' A'. Whenever the screw A' A' is turned more or less, the cylinder W W will naturally turn more or less at the same time. Here we think it necessary to observe that the endless screw A' A' wants four turns to cause the cylinder to make only one full turn.

The mechanism following hereafter is the most important, and at once the only complicated, part of the apparatus, and, therefore, I shall endeavor to describe the same as amply as possible. This mechanism consists in several parts, on the co-operation whereof it depends to cause each letter in the printed line to occupy the space wanted for its width. This part of the mechanism is represented separately in Fig. 1 in two different positions; also in Fig. 4 at the time when the frame is raised, and in Fig. 5 when it is lowered.

On the fore part of the endless screw A' A' (special-drawings) is the handle P P, turning freely round the axle of the screw A' A'. Further, there is a steel ratchet-wheel, with very fine teeth, *mm*, and after that a brass disk, *nn*, with even rim—i. e., a wheel without teeth. The handle P P is connected in the point *o* with the lever, or, rather, support *o'*, the opposite lower end whereof rests on

the foundation-plate of the apparatus. When the point A' is lowered, the handle P P, having its point of support in *o*, will rise, with its end *l^x* turning at the same time round the point A', and on the reverse, when the point A' is raised, the support *o o'*, connected with the handle in the point *o*, will lower its end *l^x*. The handle P P is connected behind with the arm *p P p'*, which turns round the point P until the end of the arm *p* touches the rim of the disk *nn*. On this arm is fastened the catch (ratchet) *r r'*, which turns round the point *r*. This catch is supported underneath by the pin *s*, toward which it is pressed by a very weak spring pressing against this catch from above.

When the frame P P is raised the arm *p P p'* is in the position shown in Fig. 4. The end *p* of the arm in this position will repose on the rim of the disk *nn*, and the ratchet must catch with its end *r'* in the teeth of the ratchet-wheel; but as soon as the point A' is lowered the handle P P must, as aforesaid, turn round the axle in the direction shown by the indicator, and as this handle, by means of the ratchet, catches in the ratchet-wheel, the ratchet-wheel of course must likewise turn in the same direction, and, together with it, also the endless screw. The screw A' A' will turn the cylinder with the paper.

Now we shall examine how the turning of the cylinder may be stopped according to the width of the letter to be printed on the paper rolled round the cylinder. The arm *p P p'* is connected with the support *p² t*, which itself is connected at its lower end with the lever *u*, turning round the point *w*. The lever *u* at its end has a pin, *v*, which constantly remains under the muff M M, and exactly opposite that row of pins of this muff which corresponds to the type and the letters the apparatus is printing.

The system of these levers acts in the following manner: When the point A' lowers, the end P of the handle will rise, causing the ratchet-wheel to turn. At the same time the support *p² t*, going down and moving in the direction of the indicator, will strive to change its inclined position for the vertical, thus diminishing the distance between the points *p'* and *t*, and causing the support *p² t* to press against the arm *t* of the lever *u*. The result of this motion will be that the end *v* of the lever must rise together with the pin. This motion of the lever is aided by a spiral spring fastened with one end to the end of the lever *t*, and with the other to the foundation-plate. The action of the lever *t u v* will last until the pin *v* touches one of the pins set in the muff M M. Thereafter, the arm *t* of the lever being prevented going down any more, the support *p² t* will begin to weigh on the point *p'*, in consequence whereof the arm *p P p'* is compelled to turn round the point P, and its end *p*, after leaving the disk *nn*, will rise; and, by aid of the pin *s*, lift the catch *r r'* out of the teeth of

the ratchet-wheel. The further motion of this wheel, as well as that of the endless screw, will then cease, and the turning of the cylinder likewise will be stopped. Consequently, when the pin *v* meets one of the pins of the muff *M M*, the longer the latter pin—*i. e.*, the narrower the letter to be printed—the faster the catch *rr* will snap off, and the less the cylinder with the paper will turn, and, vice versa, the shorter the pin of the muff *M M*—*i. e.*, the greater the width of the letter to be printed—the more the cylinder will turn, and consequently the more space will be occupied in the line by the letter. In either case the catch will snap off before the cylinder touches the drum with the type, so that at the moment of this contact the drum is not turning, and consequently the printed letters will never appear blotted. After having fully understood the action of the mechanism turning the cylinder with the paper, it is easy to comprehend the order in which the pins on the muff *M M* are distributed in accordance with the type placed in the drum *H H*. The pin *v* may, at pleasure, be lengthened or shortened, whereby all letters in the line will stand more closely or farther apart. This circumstance is very important, as it permits to place, instead of one type, into the same apparatus a larger or smaller type, whereby it is only required to lower or raise the pin *v* a little in order to place all letters of the new type in the line quite correctly, and according to the width of the new type put in. For beginning and ending the lines correctly a hand is applied to the foremost outward part of the endless screw *A A'*, moving round a small dial-plate with divisions *C'*. This hand is fixed to the axle of the endless screw in such manner that it moves along with the screw during the working. The hand can be moved alone to either side without causing the screw to stir. In order to begin the lines regularly in one line, after placing the cylinder with the paper in the apparatus, the key is applied to the foremost end of the endless screw *A A'*, and by turning the same the cylinder will likewise turn until the place where the line is to begin comes to the line in which the contact of the cylinder with the drum ensues. Hereafter the hand of the dial-plate *C'* is placed on *O*, and beginning always the lines at *O* one may be quite sure that the beginning of the lines on the printed page is perfectly correct.

The ending of the lines is performed in the following manner: On the axle of the cylinder *Z Z*, alongside of the pinion *K*, is a wheel with only one tooth, *D'*, Fig. 3, which, while the cylinder is turning, catches a hammer striking on a small bell, *E'*. This wheel turns freely on the axle, and may be, at pleasure, fixed to the axle in whatever position wanted by means of a screw passing through the nave-ring. At the beginning of working, this wheel is always fixed on the axle in such manner that during the work the bell will in due time give notice when the line is about to be finished. After

the bell has rung, a certain number of letters—fifteen to twenty—are printed to a certain degree on the dial-plate *C'*, whereby must be calculated whether the last word finds sufficient room in the line, or how it will be best divided. If required, the last spaces between the letters may be made narrower or wider.

In the position of the apparatus shown in the drawings joined to this specification, the frame *P P P P* is pressed against the drum with the type by means of two bars, the upper ends of which are fixed to the frame, and the lower ones connected, by a cross-bar, with a treadle fixed thereon. When this treadle is pressed down with the foot the frame goes down until the screws of the frame strike against the supports. These screws are adapted to serve for regulating the pressure exercised by the cylinder with the paper on the type in the drum.

If necessary, transporting the apparatus may be rendered more easy by constructing the same in such manner that the frame is lowered by a lever, to be handled by the person working at the apparatus. Likewise, to avoid the knocking caused by the screws striking against the supports, the apparatus can be so arranged that the lowering of the frame is produced by eccentrics put in motion by treadles.

3. *The ink-distributing mechanism.*—On the left-hand side of the apparatus, between two grooves fastened to the cast-iron plate, which serves as foundation, is a small slide, *q q*, moving forward and backward. On this slide stands a frame, *x x x x*, with a metallic cylinder, *y y*, turning around the axle, Figs. 1 and 3.

Before beginning to work, the ordinary lithographic ink is put on the cylinder *y y* exactly in the same way as it is done with the ink-rollers for typographic and lithographic printing. For putting on the ink easily the cylinder *y y*, together with the frame *x x x x*, is taken out of the apparatus. The cylinder *y y*, when placed in the apparatus, rests on the disk *z*, Fig. 1, which turns on an axle reposing on two supports fixed on the foundation-plate. Thus the ink passes from the roller *y y* on the disk *z*, which again transmits the same to two other rollers placed on top of the one which is fastened on the slide *B B*, carrying the drum with the type. The latter two are applied in the following manner: Through the slide *B B*, under the drum with the type, and in parallel direction to its axle, passes an axle, *m' m'*, whereon the frame *n' n' n' n'* is fastened. This frame supports the gelatine inking-roller *q' q'*, which can be pressed against the drum with the type more or less, as may be required. This pressing is produced by the screw *a'*, Fig. 1, acting on the foremost end of the axle *m' m'*, Figs. 1 and 3. On either side of the gelatine roller, on the same axle, is a toothed wheel, *s' s'*. When the roller *q' q'* is pressed against the drum the wheels *s' s'* press

against the india-rubber rings put on the drum, in consequence whereof, when the drum is turning, its motion is transmitted to the roller $q^1 q^1$, and, through the latter, also to the other ink-distributing rollers. Between the gelatine roller $q^1 q^1$ and the disk z , Fig. 1, a metallic roller is interposed, and applied to a system of levers fastened on the frame $n n n n$, in such manner that, by the aid of the screw d , the interposed roller w can be, at the same time, pressed against the disk z and the gelatine roller $q^1 q^1$, Fig. 1. The arrangement of these rollers is rendered sufficiently comprehensible by the drawings to require no further explanation. We deem it, however, necessary to observe that the disk z and the roller $y y$ are placed on the foundation-plate, and the disk z is constantly in the plane of intersection of the cylinder bearing the printing-paper and the drum, while the gelatine roller $q^1 q^1$ and the interposed roller w are moving forward and backward along with the slide B B. The disk z transmitting the ink in form of a narrow stripe, the ink will be, by this arrangement of the rollers, constantly put only on the type printed at the time. All other types will remain clean until they are in the plane of intersection of the cylinder and drum—i. e., until it is used for printing. This circumstance is of great importance, because only by this arrangement it is possible to pass, during the work, from one type to another without fearing that the type or letters that have not been printed for a long time be too abundantly inked.

Practice has pointed out the necessity to apply to the right-hand side of the apparatus, likewise, a gelatine roller resembling, in every respect, the gelatine roller on the left. This latter roller receiving the ink by its contact with the type-drum, it equalizes the ink by taking it off from the letters inked too much and distributing the same to those that were not inked sufficiently.

Destination of the apparatus.—The apparatus invented by me, and called "Fast Printer," is destined to be used—

First, in offices, chanceries, &c., for making clean printed copies, instead of copying by hand, in all cases where a fair writing is wanted. Working by the apparatus, compared with work of copyists, will offer the following advantages: (a.) It will be more speedy than ordinary copyists' writing. (b.) It demands hardly any skill whatever, and can be performed by anybody who can read and write. (c.) Working with the apparatus may be easily learned within a few days, as experience has shown. (d.) Working with the apparatus is less fatiguing. (e.) What is printed by the apparatus may be easily reproduced in any number of copies wanted. (f.) Mistakes are easily corrected.

Second, in lithographic establishments, the apparatus is destined to serve for mechanical composition, and, if so employed, it will; be-

side some of the advantages mentioned above, offer the following advantages: (a.) Composing the first proof intended to be afterward reproduced by lithography is performed more rapidly than by ordinary typographical composition. (b.) It saves the expense for purchasing and renewing type. (c.) It permits the compositor to do the work at home. (d.) In lithographic printing the drawings printed in the text will be considerably less expensive than those placed in the text of typographic printing.

I claim as my invention—

1. The type cylinder or drum H, having a series of grooves formed therein longitudinally of the axis, said cylinder having at both ends slightly-projecting rims h^2 , covered with india-rubber or its equivalent, in combination with the flat rings or disks h^3 and the set-screws h^4 , substantially as and for the purposes specified.

2. The type-cylinder H and index-dial G, in combination with the sliding frame B, operated by means of the screw J and sleeve K, the index L, and the fixed index-plate L', notched disk I, and spring U, all constructed to operate substantially as and for the purposes specified.

3. The sliding frame B, index-plate L', index L, type-cylinder H, index-dial G, and index-hand F, in combination with the paper-cylinder W, mounted upon an axis lying in a horizontal plane, and at right angles to the type-cylinder, substantially as and for the purposes set forth.

4. The paper-cylinder W, provided at one end with a spring-hook, and at the other end with a grooved disk, g , and mounted upon an axis having a longitudinal groove, b , formed therein, for the purposes described, in combination with the endless screw T, carrying a notched disk, B', and a spring disk or catch, g' , the threaded sleeve V, hook f , rod n , and sleeve h , provided with a spring, j , all arranged to operate substantially as described.

5. The rocking frame P, operated as set forth, and provided with the set-screws C d' , in combination with the columns U, having projecting studs e , for controlling and adjusting the rocking or vibrating motion of said frame, substantially as specified.

6. The type-cylinder H, in combination with the paper-cylinder W, constructed and arranged as described, the endless screw T, sleeves V h , hook f , and the rocking or vibrating frame P, all arranged to operate substantially as described, and for the purposes set forth.

7. The muff M, provided with a series of pins, corresponding in number to the number of types in the type-cylinder, the length of said pins varying according to the width of the type, in combination with the adjustable screw x , whereby the spaces occupied by said types on the paper are adjusted, substantially as specified.

8. The type-cylinder H, in combination with

the muff M and the spacing mechanism, consisting of the axle A, constructed substantially as shown and described, the ratchet-wheel m, disk n, the arm p p', pawl r r', arm P, index-dial C, connecting-rods o p', lever u, and pin v, all arranged to operate substantially as set forth.

9. The type-cylinder H, muff M, sliding frame B, paper-cylinder W, endless screw T, rod N, sleeves V h, hook f, pinion K, axle A', ratchet-wheel m, disk n, pawl r r', arms P p p', connecting-rods o p', lever u, pin v, and rocking frame P, all arranged, constructed, and combined to operate substantially as shown and described.

10. The paper-cylinder W, axis Z, and the pinion K, in combination with the axis A', disk D, tooth D', the signal-bell E', and hammer I, all arranged to operate substantially as and for the purposes specified.

11. The ink-rollers q¹ q¹, mounted upon the frames n' n', the shafts m', and set-screws d', in combination with the sliding frame B, substantially as and for the purposes set forth.

12. In combination with the rollers q¹ q¹, arranged as set forth, the roller w, arranged with capability of adjustment by means of the screw d, the disk z, roller y, mounted upon a tilting axle or frame, x, and the sliding frame q, all arranged and constructed substantially as shown, and for the purposes specified.

13. The equalizing-roller q², arranged as described, in combination with the sliding frame B and type-cylinder H, substantially as and for the purposes set forth.

14. The type-cylinder H, constructed substantially as described, in combination with the inking mechanism, arranged as set forth, and the sliding frame B and the milled wheels s s, all arranged to operate substantially as specified.

In testimony that I claim the foregoing I have hereunto set my hand.

MICHAEL ALISSOFF.

Witnesses:

N. TSHEKALOFF,
A. MICHELSSOHN.