

G. E. CLOW & P. H. WEBSTER.
WAGON-TONGUE SUPPORT.

No. 169,776.

Patented Nov. 9, 1875.

Fig: 1.

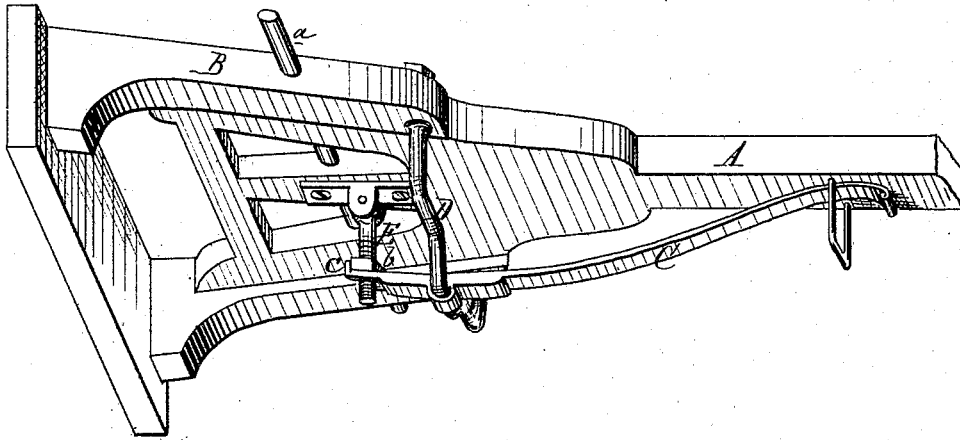

Fig: 2.

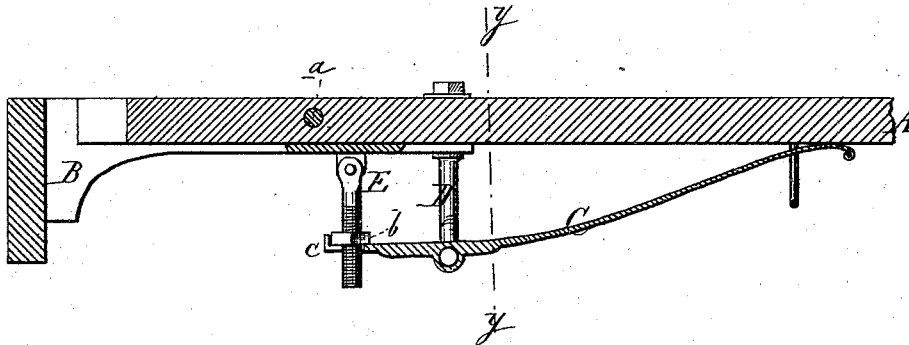
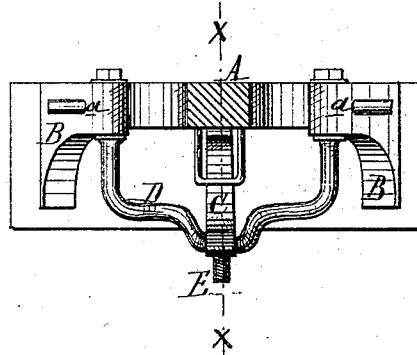

Fig: 3.



Attest.
Edward Barthel
Wm. Spalding

Inventor.
G. E. Clow
P. H. Webster
By atty
Thos. S. Sprague

UNITED STATES PATENT OFFICE.

GEORGE E. CLOW AND PERLEE H. WEBSTER, OF CHICAGO, ILLINOIS.

IMPROVEMENT IN WAGON-TONGUE SUPPORTS.

Specification forming part of Letters Patent No. **169,776**, dated November 9, 1875; application filed July 9, 1875.

To all whom it may concern :

Be it known that we, GEORGE E. CLOW and PERLEE H. WEBSTER, of Chicago, in the county of Cook and State of Illinois, have invented an Improved Wagon-Tongue Supporter, of which the following is a specification:

Our invention has for its object to provide a support for a wagon-tongue, which will have sufficient elasticity to accommodate itself to the inequalities of a rough road, while yet stiff enough to support the tongue at its proper height.

The invention consists in a strong leaf-spring pivoted to a yoke pendent from the hounds, while its rear end is forked to embrace a pendent screw hinged to the tongue, the rear end of said spring taking under an adjusting-nut on said screw.

Figure 1 is a perspective view of a tongue fitted with our supporter. Fig. 2 is a longitudinal section at *xx* in Fig. 3, which is a cross-section at *yy*.

In the drawing, A represents a tongue pivoted by the bolt *a* between the hounds B of a wagon. C is a long and stiff leaf-spring sleeved, or otherwise pivoted, on or to a yoke, D, pendent from the front ends of the hounds, its front and longer arm bearing against the under side of the tongue. E is a pendent

screw, whose head is hinged to a plate under the tongue directly over the rear end of the spring, which is forked and turned up, as at *e*, to embrace the screw and a nut, *b*, on the latter, the end taking against the bottom of the latter, while the upturned ends prevent the screw from swinging back out of the fork.

The nut is run down the screw to raise the front end of the spring far enough to support the pole at the proper elevation, while the elasticity of the latter will overcome the difficulties attendant upon the use of a rigid tongue-supporter.

We are aware that a leaf-spring has heretofore been used in a tongue-supporter for wagons as described in the patent granted to Higley and Toothaker, March 5, 1867, No. 62,651, and we do hereby disclaim the broad invention of the same.

What we claim as our invention is—

The spring C, yoke D, screw E, and nut *b*, in combination with the tongue and hounds of a wagon, substantially as and for the purpose set forth.

GEORGE E. CLOW.
PERLEE H. WEBSTER.

Witnesses:

WM. H. LOTZ,
GEO. FROMMANN.