

F. A. H. DONATH & C. E. F. JASPER.  
CIGAR-MACHINE.

No. 169,786.

Patented Nov. 9, 1875.

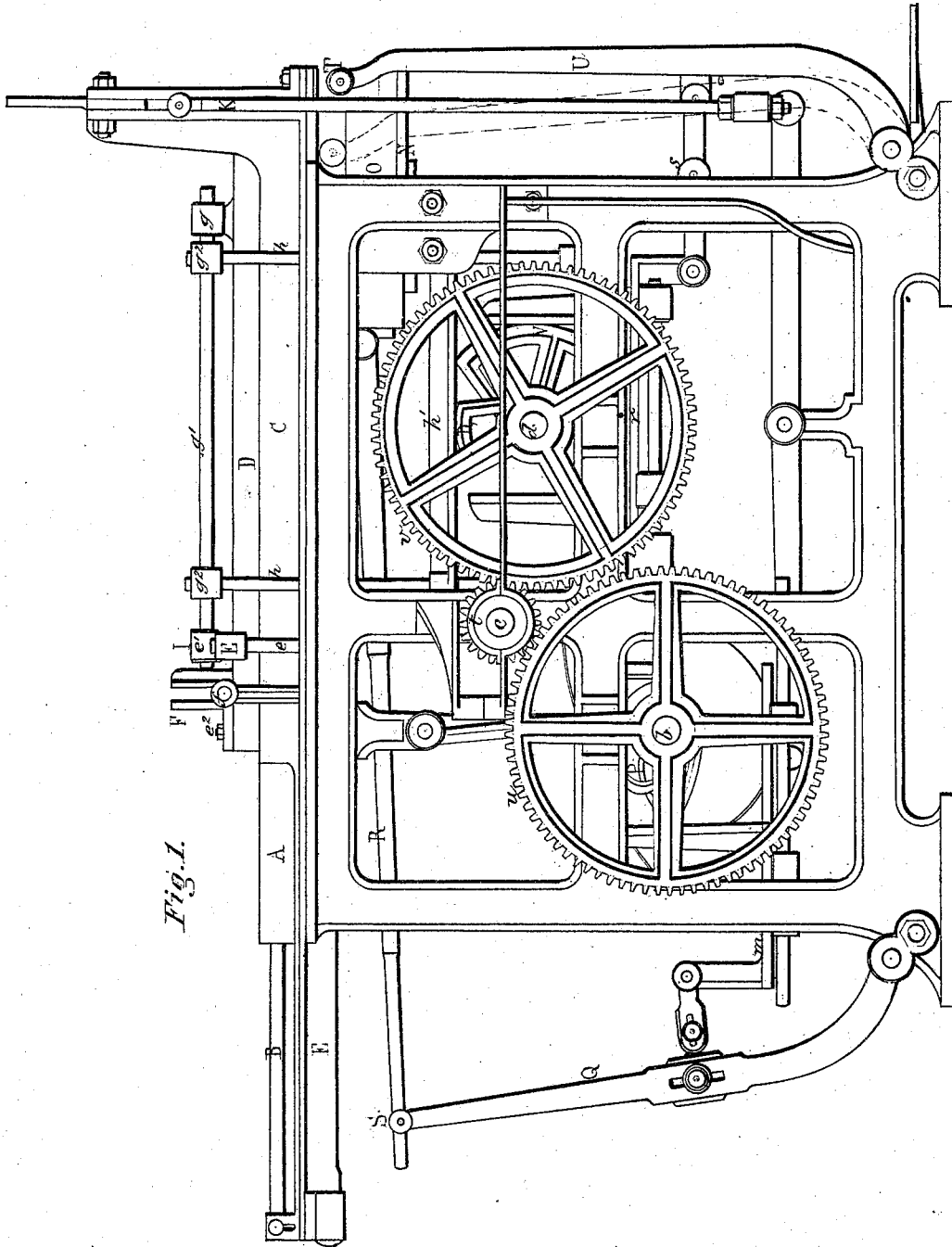

Fig. 1.

Witnesses:  
J. G. Skidmore.  
H. N. Burton

F. A. H. Donath  
C. E. F. Jasper  
By their attys  
Howson & Son

F. A. H. DONATH & C. E. F. JASPER.  
CIGAR-MACHINE.

No. 169,786

Patented Nov. 9, 1875.

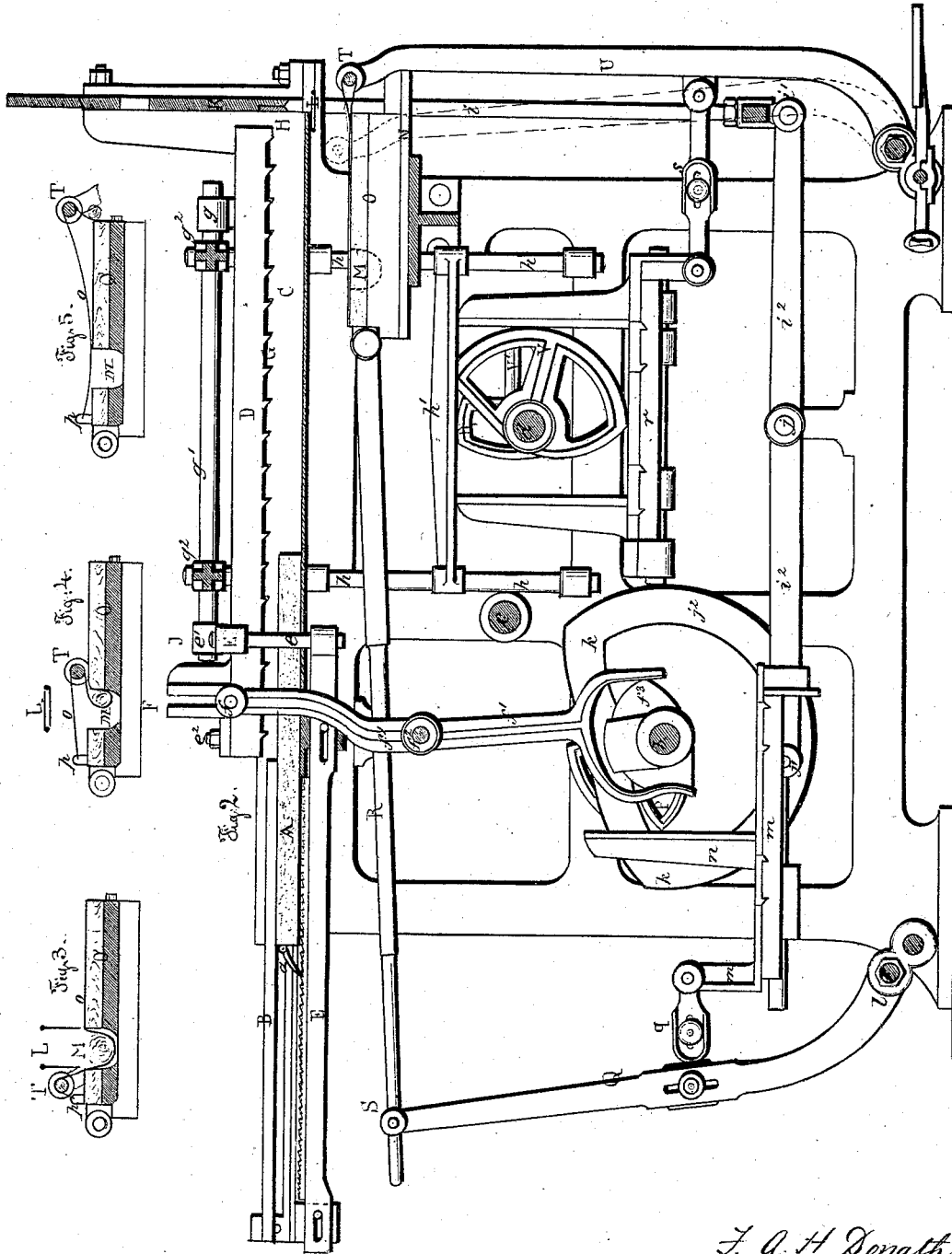

Witnesses:  
J. W. Skidmore.  
H. H. Burton.

F. A. H. Donath  
C. E. F. Jasper  
By their attys.  
Howson & Co.

# UNITED STATES PATENT OFFICE.

FERDINAND AUGUST HERMANN DONATH AND CARL ERDMANN FRIEDRICH JASPER, OF DRESDEN, SAXONY.

## IMPROVEMENT IN CIGAR-MACHINES.

Specification forming part of Letters Patent No. 169,786, dated November 9, 1875; application filed February 13, 1875.

*To all whom it may concern:*

Be it known that we, FERDINAND AUGUST HERMANN DONATH and CARL ERDMANN FRIEDRICH JASPER, both of Dresden, in the Kingdom of Saxony, have invented a new and useful Improvement in Cigar-Rolling Machines, of which the following is a specification:

Our invention relates to machinery for rolling cigars; and it consists in an improved machine in which the tobacco is automatically fed toward the rolling device, cut, and rolled into the perfect shape of a cigar, save the point, by certain novel mechanism, hereinafter more fully described.

In the accompanying drawings, Figure 1, Sheet I, represents a side elevation of our improved cigar-machine. Fig. 2, Sheet II, represents a vertical longitudinal and central section of the same; Figs. 3, 4, and 5, Sheet II, detached views of parts of the machine.

Like letters of reference indicate like parts in the several figures.

Our improved machine performs three separate functions—to wit, the feeding of the requisite quantity of filling-tobacco, the cutting of the same from the balance of the filling-tobacco in the feed-gutter, and delivering the same to the wrapper on the rolling-strap, and the rolling of the cigar into shape.

In the accompanying drawings, A represents a sheet-metal feed-trough, in which the filling-tobacco is placed, having previously been cut into the proper size. This feed-trough slides forward and back in a gutter, C, formed on the top plate of the machine, and is propelled backward automatically by means of a pawl, *a*, hinged to its end, which pawl seizes on a ratchet-bar, E, having a reciprocating movement under the top plate, a slot being formed in the latter to allow the pawl to seize on the ratchet-bar. This ratchet-bar E has a forked rear end, through each fork of which passes a vertical rod, *e*, having free play in the forks, and being connected, after passing upwardly through the top plate, one on each side of the gutter C, to the feed-block D by means of short bars *e*<sup>1</sup>. On the feed-block D, forward of the bars *e*<sup>1</sup>, is secured a

forked piece, F, which is longitudinally adjustable on the feed-block D by means of slots in its lower flanges, through which set-screws *e*<sup>2</sup> pass into the feed-block. Between the forks of this piece F is held a short cross-bar, *f*, to each end of which, one on each side of the gutter, and also passing through the top plate, are two levers, *f*<sup>1</sup>, pivoted on a cross-bar, *f*<sup>2</sup>, secured to the side frames of the machine, and forked at their lower ends, which forks are operated by cams *f*<sup>3</sup> on a shaft, *b*, so as to give to the levers *f*<sup>1</sup>, and through them to the feed-block D, and also to the ratchet-bar E, a reciprocating movement, the extent of which is regulated by adjusting the forked piece F. At the rear end of the feed-block D are secured standards *g*, in which the cross-bars *e*<sup>1</sup> are secured the ends of round bars *g*<sup>1</sup>, on which sleeves *g*<sup>2</sup> slide freely, from which latter rods *h* extend downward through the top plate, two on each side of the gutter, and each two on one side a suitable distance from each other. Each two of these rods *h* on one side are secured and connected by cross-bars *h*<sup>1</sup>, firmly secured to them, at such a distance above a shaft, *d*, that cams D', one on each side on said shaft, operate on these cross-bars *h*<sup>1</sup>, so as to lift them, and through them and the rods *h* and bars *g*<sup>1</sup> the feed-block D, which latter may, by reason of the freely-sliding sleeves, have also a reciprocating motion at the same time while it is lifted. The feed-block D, at its under side, is provided with teeth G, and at the rear with corrugations H, which retain the rear portion of the material, so that it cannot escape or fall forward toward the knife.

Moving in suitable guides at the rear end of the machine, and at right angles to the gutter, a vertical knife, K, is periodically drawn downward across the end of the gutter C by means of vertical rods *i*, one on each side, the lower ends of which are connected by a cross-bar, *i*<sup>1</sup>, to which is pivoted a lever, *i*<sup>2</sup>, pivoted itself at *j*, the forward forked ends of which are provided with rollers *j*<sup>1</sup>, moving in grooves *j*<sup>2</sup>, one on each side of a cam, *k*, secured on shaft *b*. Directly under the knife K are pivoted two gates, L, which, when hori-

zontal, overlap each other, as shown in Fig. 4, and are dropped vertically, and afterward replaced to their normal position periodically, by mechanical means not especially detailed here, and which are not material to this invention, as this movement of the gates can easily be effected by cams and springs. Below the gates L, and at a suitable distance not to interfere with their dropping, are secured ways N to the side frames of the machine, on which the rolling-board O has a reciprocatory movement, which is effected through a lever, Q, pivoted at *l* to a shaft, *U*, having its bearings in the side frames at the bottom, which is connected to the rolling-board O by means of a pivoted rod, R, the length of the reciprocating movement of the board O being adjusted by regulating the rod R at S, and the lever Q at the point of its connection to the slide *m*, as clearly shown in Fig. 1. The lever Q is operated from the slide *m*, to which it is connected by means of a short rod, *g*, pivoted with one end to slide *m*, and with the other to lever Q.

The slide *m* is provided with standards *n*, one at the rear end of one side, and the other at the front end of the opposite side, of the slide, against which standards *n* cams P on shaft *b* operate alternately. The rolling-board O has near its front end a semicircular recess, M, and is covered by a strap, *o*, of any suitable strong and flexible material, somewhat longer than the board, which strap is secured with its front end to a rib, *p*, on the front end of the rolling-board, and with its rear end to the rear edge of the board. Between the strap *o* and the rolling-board O, at a suitable distance above the latter, a rolling-bar, T, having its bearings in two vertical levers, U, moves forward and back, receiving its reciprocating motion through cams V and V' on the shaft *d*, which cams alternately operate against standards on a slide, *r*, connected by a crank-arm, *s*, to the levers U.

The main working-shaft *c* of the machine carries at one end a pulley, and at the other end a small gear-wheel, *t*, gearing with toothed wheels *u* and *v* on the shafts *b* and *d*, respectively, thus giving motion to the latter.

A weighted cover, B, hinged to the front end of the frame of the gutter, is used to keep the filling-tobacco firmly down in the trough.

After having described the several parts of our machine, we will now proceed to describe its operation. Motion being imparted to the shafts *b* and *d* through the main shaft *c* and gear wheels *t*, *u*, and *v*, the feed-block D is lifted above the filling-tobacco in the gutter C by means of one cam, D', and is then moved forward, together with the ratchet-bar E. As the feed-block D is lowered its teeth G and corrugations H seize on the tobacco in the gutter C, and push the tobacco backward under the knife K, the feed-trough A also pushing the tobacco along. The extent of this movement of the feed-block and ratchet-bar

determines the size of the cigar by regulating the amount of tobacco pushed backward, and can be regulated as above described.

The knife K is now forced downward, and cuts off the tobacco, which latter falls on the hinged gates L, at that moment held in a horizontal position. The knife K, which has, by its downward movement, cut off the required amount of tobacco, is now again lifted by means of the grooved cam *k*, and lever *i*<sup>2</sup>, cross-bar *i*<sup>1</sup>, and rods *i*. The hinged gates L now drop into a vertical position, allowing the tobacco to fall onto the strap *o*, over the rolling-board O, the tobacco falling into the recess M, depressing the strap *o* also into the same. At this moment the rolling-bar T has reached the extreme forward point of its reciprocating movement. The workman has at this moment also placed the wrapper of the cigar on that portion of strap *o* between the recess M and the rear end of the rolling-board. These parts now are all in position, as shown in Fig. 5. As the gates L are now again lifted into their horizontal position, the rolling-bar T begins its backward movement, thereby lifting the tobacco on the strap in recess M out of the latter in a fold of the strap, rolling at the same time the tobacco into the wrapper on the strap. The movement of the rolling-bar T ceases at the point shown in Fig. 4, when the forward movement of the rolling-board begins, which movement finishes the rolling of the filling-tobacco into the wrapper, and throws the cigar off into the hand of the workman, or any suitably-arranged receptacle, as shown in Fig. 5.

By adjusting the length of the movement of the rolling-board, through the adjustment of the rod *g* on the lever Q at S, and of lever Q at its pivot, the cigar may be rolled tighter or looser, and may be made thicker and thinner, while the length of the cigar may be regulated by inserting side pieces into the gutter C, to reduce the length of the cigar.

The point is given to the cigar after its being rolled on the machine, either by hand or any suitable mechanical device.

Having thus described our invention, we claim—

1. The bar D, reciprocating vertically and longitudinally, and having a series of teeth at the lower side, in combination with the stationary gutter C, sliding feed-trough A, and cutter K, substantially as set forth.

2. The combination of the board O, its operating-lever Q, and the slide *m*, having an adjustable connection with the lever, as set forth.

3. The combination of the bar E, feed-block D, levers *f*<sup>1</sup>, and cam *f*<sup>3</sup>, for imparting a longitudinal reciprocating movement to both the bar and the feed-block, and devices, substantially as described, for imparting a vertical reciprocating movement to the feed-block, all operating together to carry the tobacco to the cutter, as specified.

4. The feed-block D, combined with the sliding bar E, and with cams on the shaft  $\bar{d}$  and rods  $h h'$ , whereby a vertical reciprocating movement is imparted to the block, all as set forth.

5. The combination of the rods  $h h'$  and bars  $g^2$ , to which a vertical reciprocating movement is imparted by cams on the shaft  $\bar{d}$ , and

the feed-block D, provided with rods  $g^1$ , sliding in the bars  $g^2$ , as specified.

FERDINAND AUGUST HERMANN DONATH.  
CARL ERDMANN FRIEDRICH JASPER.

Witnesses:

ALFRED ADOLF OSCAR MAMOZINSKI,  
CONRAD WILHELM HANDSKE.