

S. C. MEGILL.

DENTAL AND BARBERS' CHAIR.

No. 169,825.

Patented Nov. 9, 1875.

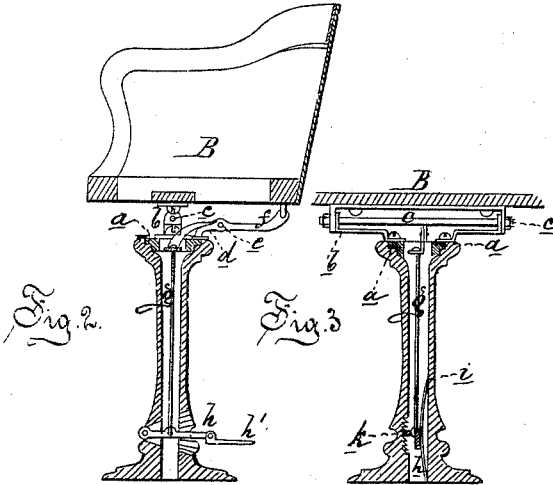
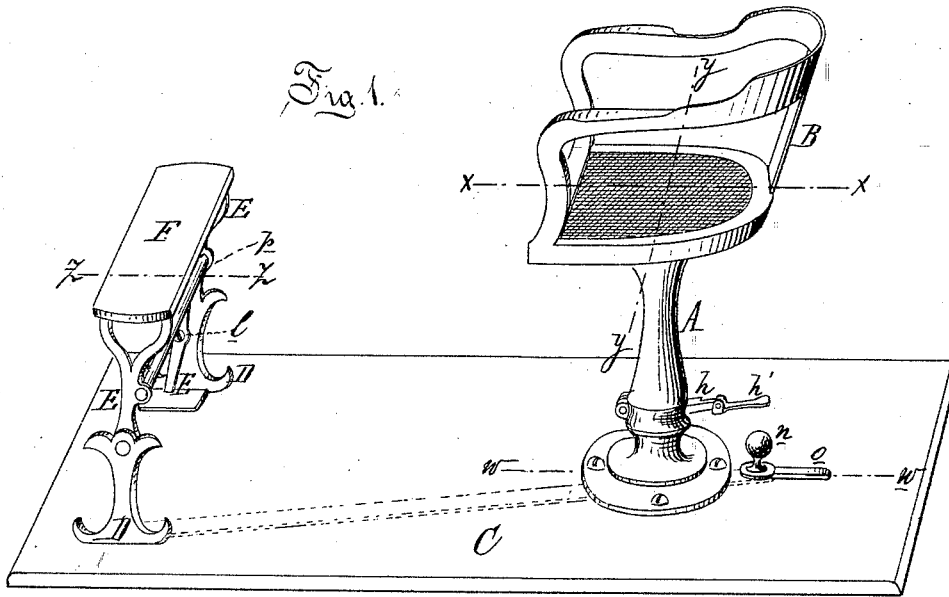

Attest:
 Edward Parthel.
 H. F. Eberst.

Inventor:
 Sebring C. Megill,
 per Attorney
 Wm. S. Sprague

S. C. MEGILL.

DENTAL AND BARBERS' CHAIR.

No. 169,825.

Patented Nov. 9, 1875.

Fig. 4.

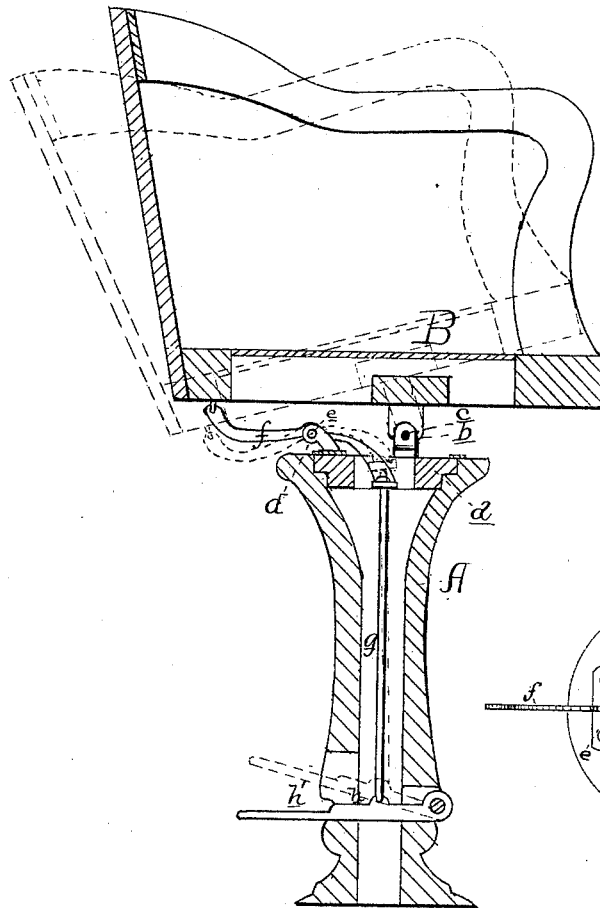
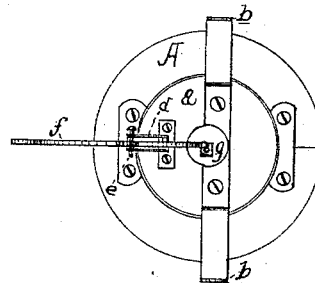

Fig. 5.



Attest:
 Chas Thurman,
 R. C. Dyer

Inventor:
 Sebring S. Megill
 by Geo. W. Dyer & Co
 Attys.

UNITED STATES PATENT OFFICE.

SEBRING C. MEGILL, OF CHICAGO, ILLINOIS.

IMPROVEMENT IN DENTAL AND BARBERS' CHAIRS.

Specification forming part of Letters Patent No. **169,825**, dated November 9, 1875; application filed June 3, 1875.

To all whom it may concern:

Be it known that I, SEBRING C. MEGILL, of Chicago, in the county of Cook and State of Illinois, have invented an Improvement in Dental and Tonsorial Chairs, of which the following is a specification:

My invention relates to an improvement in dentists' and barbers' chairs, having for its object to so construct a chair that the operator can, by means of a pedal, tilt the seat, and lock it at any required angle of inclination, while the seat will at all times be free to rotate upon its fixed standard, as more fully hereinafter set forth.

Figure 1 is a perspective view, showing my improved chair mounted on a platform. Fig. 2 is a longitudinal vertical section through the chair and standard at *x x* in Fig. 1. Fig. 3 is a transverse vertical section at *y y* in the same figure. Fig. 4 is an enlarged vertical section of my device, showing in dotted lines the position of the several parts when the chair is tilted; and Fig. 5 is a top view of the standard, with the chair-seat removed.

In the drawing, A represents a standard, in the form of a hollow pillar, secured by screws to the floor, or to a suitable platform, and having in its top an annular turn-table, *a*, to which are secured two upturned brackets, *b b*, diametrically opposite to each other, to the ends of which two lugs, pendent from the chair-seat B, are pivoted by a transverse bolt, *c*, whereby the seat may be tilted on the joint so made. *d* is a curved fulcrum rising from the back part of the turn-table *a*. Its rear end is forked, and between the forks, at *e*, is pivoted a curved lever, *f*, whose rear end is coupled with the back part of the seat-rim, and whose front end is turned down into the

axis of the turn-table, where it is flattened and perforated to receive a round rod, *g*, which is passed down into the hollow standard, and is arrested by a head at the top end, the lever thus rotating with the turn-table without moving the rod, the lower end of which is hooked into an eye in a pedal lever, *h*, pivoted at its front end in a slot in the lower part of the standard, the rear end extending through a slot in the rear side of said standard, which slot is provided with a ratchet-plate, *k*, on one side, to lock down the lever to any position into which it may be depressed. The lever is kept in engagement with the ratchet by a long leaf-spring, *i*, on the other side. The outer end of the lever *h* has a folding pedal, *h'*, pivoted to it. The standard A is bolted to a light platform, C, having a foot-rest; but it can be supported upon suitable casters.

It will be noticed that the seat can be rotated on its vertical axis while locked at any angle of inclination—a feature of importance in the execution of dental operations.

What I claim as my invention is—

1. In a chair rotating upon a fixed standard, substantially as described, the lever, rod, and pedal, combined with a fulcrum upon the turn-table for tilting the chair, substantially as set forth.

2. In a chair rotating upon a fixed standard, substantially as described, a fulcrum upon the turn-table, the lever, rod, and pedal, combined with a device for locking the chair at various angles of inclination, substantially as set forth.

SEBRING C. MEGILL.

Witnesses:

THOS. W. McMILLAN,
WM. H. LOTZ.