

J. W. NESMITH.  
SPARK-ARRESTER.

No. 169,831.

Patented Nov. 9. 1875.

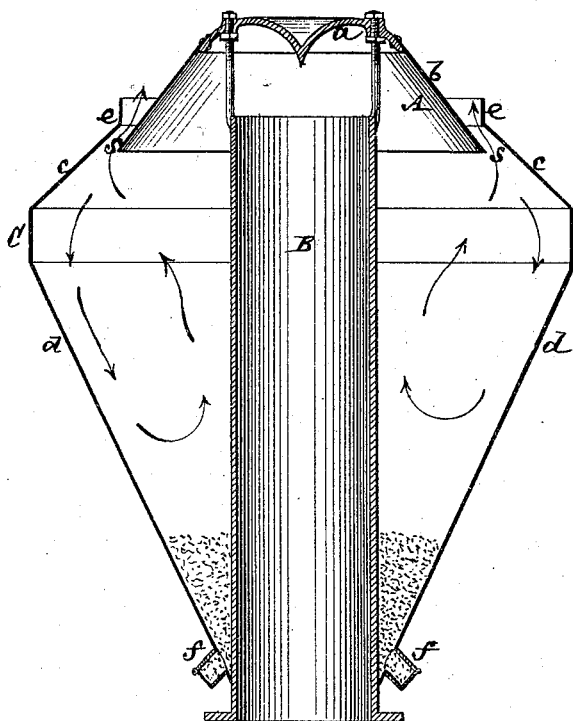

Witnesses:  
Benjamin W. Hoffman  
Fred. Waynes

J. W. Nesmith  
by his Attorneys  
Brown & Allen

# UNITED STATES PATENT OFFICE

J. WELLINGTON NESMITH, OF GOLDEN, COLORADO.

## IMPROVEMENT IN SPARK-ARRESTERS.

Specification forming part of Letters Patent No. 169,831, dated November 9, 1875; application filed October 6, 1875.

*To all whom it may concern:*

Be it known that I, J. WELLINGTON NESMITH, of Golden, Jefferson county, and State of Colorado, have invented a new and useful Improvement in Smoke-Stacks for Locomotive-Engines; and I do hereby declare that the following is a full, clear, and exact description of the same, reference being had to the accompanying drawing, which forms part of this specification.

This invention has for its object the production of a smoke-stack for coal-burning locomotive-engines, which, while it possesses every efficiency in point of draft and economy as regards the consumption of fuel by the engine, serves most effectually to prevent the escape of sparks and cinders from the stack.

The invention consists in a peculiarly-constructed spark arrester and deflector, arranged within the upper portion of the stack-head, in combination with a smoke-flue, arranged to enter up within the mouth of the deflector, whereby reverse currents are produced within the stack-head during the escape and stoppage of the exhaust-steam from the engine, and an eddying action of the currents in said head is obtained, giving increased efficiency to the stack.

The drawing represents a sectional elevation of a locomotive-engine smoke-stack having my invention applied.

A is a hollow cone or inverted conical pot, the upper part *a* of which may be of cast-iron, and its lower and larger portion or sides *b*, which are free from excessive wear, be made of sheet-iron, and riveted to the upper part *a*. B is the smoke-flue, up through which the products of combustion from the furnace and exhaust-steam of the engine pass. Said flue has no flaring top, but may be straight throughout its length, and is extended to enter partly up within the hollow cone A, the interior of the top of which latter I prefer to make of a concave annular form, for the purpose of more effectually distributing and deflecting the incandescent particles or cinders. The lower end or mouth of the hollow cone A is considerably larger than the entering top of the smoke-flue, in order that said cone may present a full and sufficient opening for the arrested hot or burning particles to be de-

flected and discharged below, as hereinafter described. C is the stack-head, which consists of two frustums of cones, *c d*, connected at their bases, and a contracted upper portion, *e*. Said stack-head is made of more than ordinary large diameter at its bilge for an engine having a given diameter of cylinders; and to utilize all the room for a proper action of the stack the cone A, which may be secured by springs, or in any other suitable manner, is set as high as possible above the entering end of the flue B, and so that its lower open and widest end or mouth comes within or slightly below the contracted upper portion *e* of the stack-head, leaving a contracted opening, *s*, between the stack-head and mouth of the cone.

The operation is as follows: The products of combustion are carried forcibly up by the exhaust-steam from the engine, through the flue B, and strike the cone A. This arrests the whole current, and, by means of the cone or conical deflector A, causes it not only to be deflected downward, but outward, following the direction given by the sides *b* of said cone, and impinging against the upper part of the lower conical portion *d* of the stack-head, all around the latter, and from thence following the portion *d* of the stack-head downward. Now, the only point of egress from the inside of the stack-head C to the atmosphere is by the contracted opening *s* between the mouth of the deflecting-cone A and the upper part of the stack-head; but a current, to pass up through this space *s*, must also pass from the inside of the stack-head through the obliquely-downward and outer current from the flue B, which gets its direction from the sides *b* of the cone A, and the exhaust downward and outward from said sides *b* cuts off the upward current from the stack-head, and stops it for a time—that is, during each escape of exhaust-steam from the cylinder. In this manner the currents have an alternating and eddying action—that is to say, a downward current is produced at the instant of each exhaust from the engine through the flue B and cone A into the stack-head, and then an upward current—that is, between the periods of exhaust from the engine—out through the opening *s*. It consequently will be seen that the deflecting of the current of the products of combustion

and steam downward and outward toward the portion *d* of the stack-head is absolutely essential to secure the action as described.

By the arrangement of the parts and enlarged size of the stack-head as described, there is provided all possible chance and the greatest amount of room for the currents to become more gentle and easier broken up and thrown into eddies by the action of the currents crossing each other, thereby affording a perfect opportunity for the sparks or hot solid particles and cinders to settle down within the bottom of the stack-head, from whence they may be withdrawn from time to time, as required, by one or more openings, *f*, which should be closed by lids or doors.

I claim—

The hollow cone A, arranged to project above the lower edge of the upper reduced portion *e* of the stack-head C, but with its mouth arranged to project within or below said upper reduced portion *e*, leaving a contracted opening, *s*, between it and said head, and with its sides *b* inclining in a reverse direction to the sides or portion *d* of the head, in combination with the flue B, arranged to enter up and open within the mouth of the cone A, substantially as shown and described.

J. WELLINGTON NESMITH.

Witnesses:

E. W. ROLLINS,  
W. C. ARMOR.