

C. J. WILEY.  
 PRINTING TELEGRAPHS.

No. 169,875.

Patented Nov. 9, 1875.

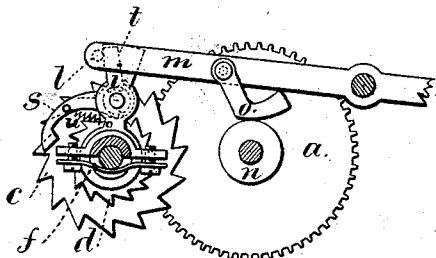

Fig. 2.

Fig. 1.

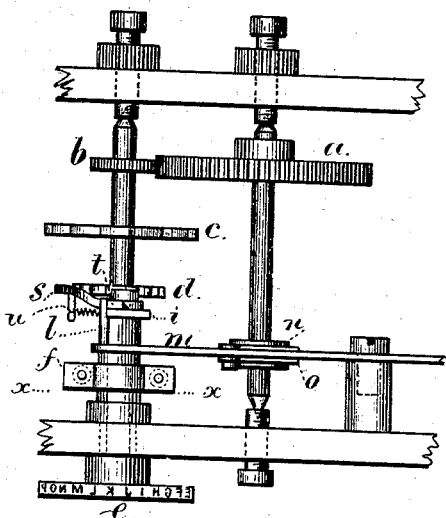
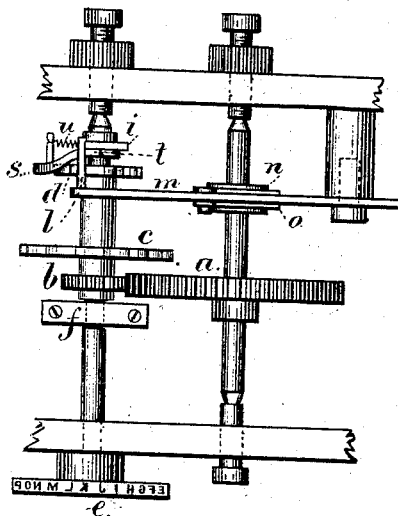

Fig. 3.



Witnesses

Charles H. Smith  
 Harold Serrell

Inventor

Charles J. Wiley.  
 per Lemuel W. Serrell  
 atty.

# UNITED STATES PATENT OFFICE.

CHARLES J. WILEY, OF NEW YORK, N. Y.

## IMPROVEMENT IN PRINTING-TELEGRAPHS.

Specification forming part of Letters Patent No. 169,875, dated November 9, 1875; applicated filed October 12, 1875.

*To all whom it may concern :*

Be it known that I, CHARLES J. WILEY, of the city and State of New York, have invented an Improvement in Printing-Telegraphs, of which the following is a specification :

In Letters Patent No. 2,373, granted in Great Britain in 1858, there is a type-wheel that is revolved by a clock-movement and a frictional connection therewith. There is a lever that acts to stop the type-wheel at a unison-point, and there is a means for liberating the unison device in the act of printing.

My present invention is an improvement upon the same; and consists in a locking mechanism applied between the type-wheel and the motor, in combination with the unison-stop applied in such a manner that when the unison mechanism operates to hold the type-wheel the motive power is disconnected, and may revolve to a greater or less extent under the control of the escapement and electro-magnets, and as soon as the printing mechanism or other device moved by magnetism operates to liberate the unison the locking mechanism is simultaneously thrown into action and connects the motive power with the type-wheel.

In the drawing, Figure 1 is a plan of the improved unison device. Fig. 2 is a section of the same at the line *x x*, and Fig. 3 is a plan of the same parts, arranged a little differently.

The wheel *a* represents any wheel in the train of gearing or clock movement from which the power is taken to revolve the pinion *b*. This pinion *b* and the ratchet-wheels *c* and *d* are connected together by being on the same shaft, as in Fig. 1, or sleeve, as in Fig. 3, and the type-wheel *e* is not attached directly to these wheels, but there is a frictional clamp, *f*, that intervenes. The ratchet-wheel *e* is under the control of the escapement usually employed in printing-telegraphs that are operated by the magnet or magnets in which the pulsations of electricity act; hence the ratchet-wheels *c d*, pinion *b*, and train of clockwork are entirely under the control of the escapement and its magnets regardless of the unison-stop *i* that is connected with the type-wheel. This unison-stop *i* is an arm, and it is attached either to the shaft, as in Fig. 3, or to

the sleeve, as in Fig. 2, so as to stop the type-wheel when the pin *l* upon the arm *m* comes into contact with said stop. This arm or lever *m* is moved toward the stop *i* gradually by the action of the wheel or surface *n* rolling against the hanging cam *o* and gradually moving the same, so as to lower the lever *m*. This lever *m* is connected with the printing-lever or operated by a magnet, so as to be thrown out of the way as often as an impression is taken. The pawl *s* is connected with the stop *i*, and there is an arm, *t*, adjacent to the stop to be acted upon by the pin *l* and raise the pawl from the teeth of the ratchet *d*, as the type-wheel is stopped; hence the said ratchet-wheel *d*, and the wheel *c*, and pinion *b* can continue to revolve after the type-wheel has been stopped, and as the unison is liberated the pawl *s* also is liberated and locks the type-wheel to the motor through the wheel *d*, so that the type-wheel revolves in harmony with the escapement, and is in the correct position to be printed from whenever a pause takes place in the rotation of the type-wheel. It is to be understood that the small spring *u* must not be so strong as to prevent the pawl being raised, because the friction applied at *f* to tend to move the pawl must be enough to cause the point of the pawl to be raised from the teeth of the wheel *d*.

I claim as my invention—

1. The combination, with the type-wheel and a unison-stop, of a frictional connection to the motive power, and a ratchet-wheel and pawl that connects and disconnects the type-wheel and its motor, substantially as set forth.

2. The lever *m*, pin *l*, and hanging cam *o*, in combination with the unison-stop *i*, pawl *s*, ratchet-wheel *d*, and type-wheel, substantially as set forth.

3. In a printing-telegraph instrument, the combination of a locking mechanism with the type-wheel and escapement for connecting and disconnecting such type-wheel from the escapement.

Signed by me this 11th day of October, A. D. 1875.

CHARLES J. WILEY.

Witnesses:

GEO. T. PINCKNEY,  
CHAS. H. SMITH.