

A. D. B. WOLFF.
PIANO ATTACHMENT.

No. 169,877.

Patented Nov. 9, 1875.

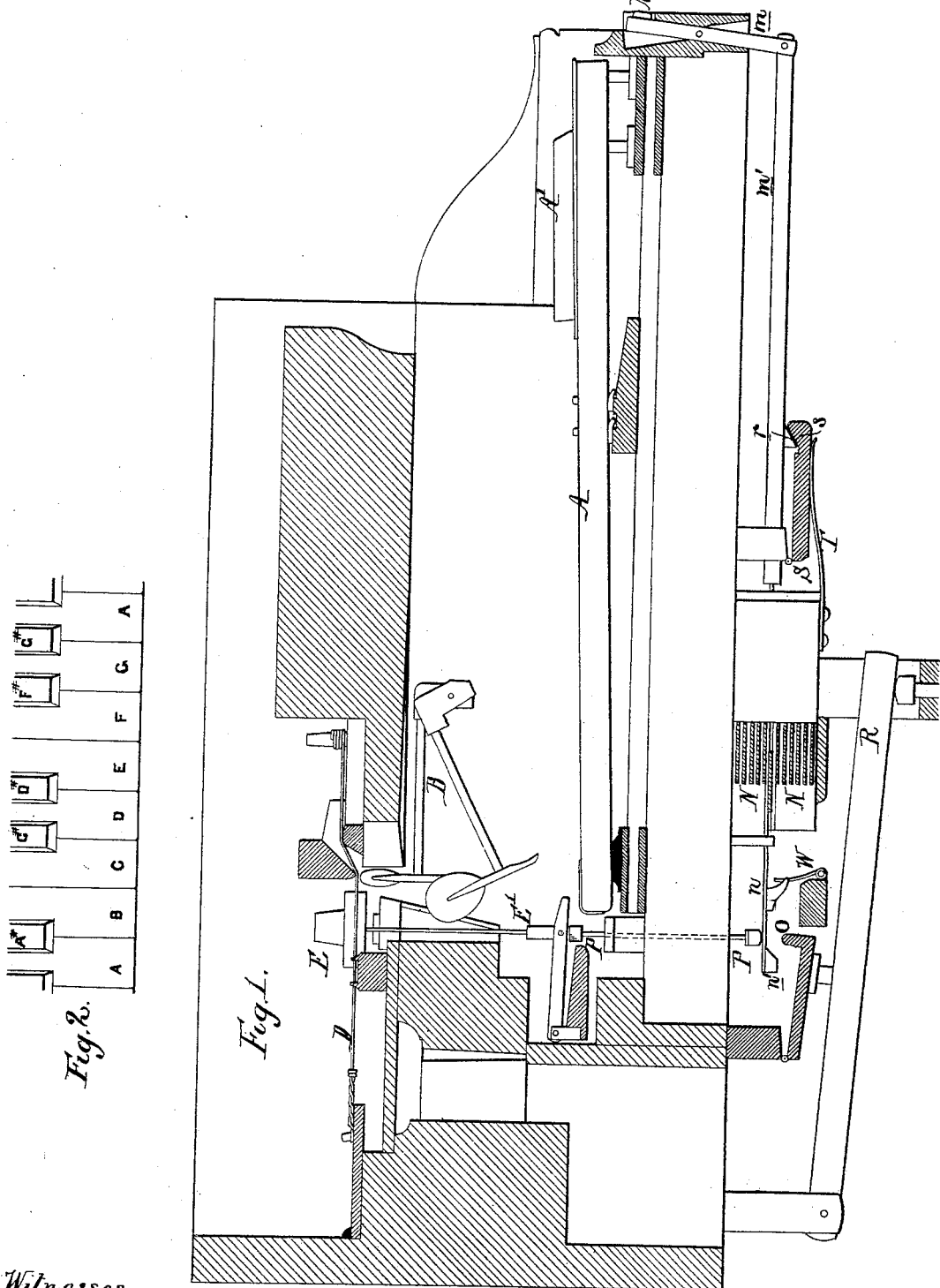

Witnesses,
Harry Smith
Hubert Houston

A. D. B. Wolff
by his attorneys,
Houston and Smi

UNITED STATES PATENT OFFICE

AUGUSTE DÉsirÉ BERNARD WOLFF, OF PARIS, FRANCE.

IMPROVEMENT IN PIANO ATTACHMENTS.

Specification forming part of Letters Patent No. 169,877, dated November 9, 1875; application filed June 18, 1875.

To all whom it may concern:

Be it known that I, AUGUSTE DÉsirÉ BERNARD WOLFF, of Paris, France, have invented certain Improvements in Pianos, of which the following is a specification:

The object of my invention is to so construct the mechanism for operating the dampers of a piano as to enable the performer to allow some of the wires struck by the hammer to vibrate, while the other wires are under the influence of the dampers; and this object I attain in the manner which I will now proceed to describe, reference being had to the accompanying drawing, in which—

Figure 1 is a sectional view of a grand piano with my improvements, and Fig. 2 a diagram illustrating my invention.

In pianos as usually constructed the dampers are all hinged to a movable frame, and when it is desired to permit any of the wires to vibrate, after being struck by the hammer, this frame, operated by the proper pedal, raises all the dampers; hence, in playing many pieces, a considerable number of wires producing inharmonious notes are vibrated with the wires which impart correct ones.

I overcome this objection by placing the damper of each wire separately under the control of the performer in the manner shown in the drawing, in which—

A A' represent the keys; B, the hammers; D, the wires; E, the dampers; and E', the damper-rods. In the front of the piano, preferably below the key-board, as shown in Fig. 1, is arranged a series of twelve buttons, M, extending about the length of an octave. Each of these buttons is connected through the medium of a lever, *m*, and rod *m'* to a wooden strip, N, these strips extending throughout the length of the sixty-four dampers of the piano, and being arranged to slide horizontally one upon another. To each of these strips N are attached a number (as many as there are octaves in the piano) of metal rods *n*, which are so arranged in respect to the hinged bar O that when a strip, N, is drawn toward the operator, the pad *n'* on a rod, *n*, is interposed between the rod P and bar O. These rods P are each arranged directly below one of the damper-rods E'. The hinged bar O is under the control of the pedal-lever R, which

I prefer should occupy a position between the two usual pedals of the piano.

Each button M and its strip N control the notes of every octave. Thus if the wires *n* of the first strip N are in communication through the rods P and E' with the dampers of the notes A in every octave, the second strip communicates with the dampers of A-sharp, the third strip with the dampers of B, and so on for the remaining nine. (See Fig. 2.) In other words, the first button controls the A-notes, the second the A-sharp notes, and so on.

Thus, by pressing on any one or more of the buttons M, the operator can interpose the corresponding pads *n'* between the rods P and hinged bar O, and, by operating the pedal R, can raise any one or more sets of dampers independently of the others.

I prefer to employ the following device for maintaining the rods *m'* and strips M in position when a button has been pressed: On the rod *m'* is a tooth, *r*, whose normal position is in the groove *s* of the hinged bar S when a strip, N, has not been drawn toward the operator. A spring, T, exerts a constant pressure on this bar toward the rods *m'*. When a button is pressed for the purpose of interposing the pads *n'* between the bar O and rods P, the tooth *r* is drawn over the inclined portion *s* of the hinged bar S, the end of which then retains it in position.

It will be evident that when one of the rods *m'* is drawn outward any of the other rods which may have been retained by this table will be released and will return to their normal positions under the influence of the springs W, Fig. 1.

In some cases it may be more convenient to hinge the bar S above the rods *m*, which will then have their teeth *r* on the upper side, and the bar will act by its own weight, the spring T being dispensed with.

If desired, the rods *m* may be operated from above the key-board instead of from below.

A supplementary thirteenth button, M, with its rod *m'* and tooth *r*, may be employed for the purpose of releasing any of the twelve damper-operators in the manner described without necessitating the bringing into operation of any of the latter.

I claim as my invention—

1. The combination of the damper-rods E' of a piano with rods P, hinged bar O under the control of a pedal, and pads *n'* with mechanism for interposing the latter between the said bar O and rods P, as and for the purpose set forth.

2. The combination of the hinged bar S, having an inclined portion, *s*, with the rods *m* and their teeth *r*, arranged to operate as set forth.

In testimony whereof I have signed my name to this specification in the presence of two subscribing witnesses.

AUGUSTE DÉSIRES BERNARD WOLFF.

Witnesses:

EMILE RICHARD,
ROBT. M. HOOPER.