

O. E. FORD.
CAR-COUPLING.

No. 169,981.

Patented Nov. 16, 1875.

Fig: 1.

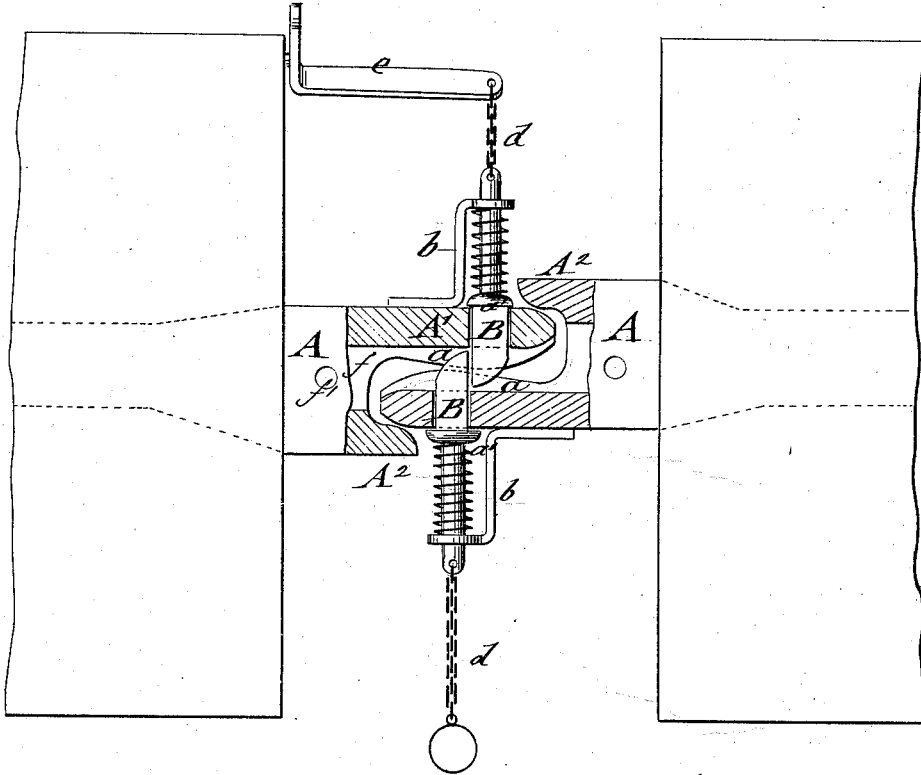

Fig: 2.

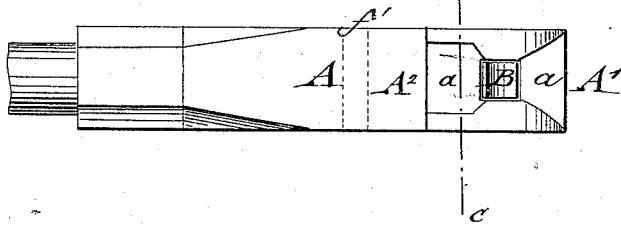
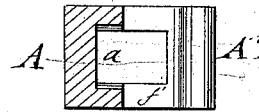

Fig: 3.



WITNESSES:

*Chas. N. ...
A. F. Terry*

INVENTOR
O. E. Ford
BY *Mumford*
ATTORNEYS.

UNITED STATES PATENT OFFICE.

OSCAR E. FORD, OF MERIDIAN, MISSISSIPPI, ASSIGNOR TO HIMSELF AND
MINOR B. CLINTON, OF DALLAS, TEXAS.

IMPROVEMENT IN CAR-COUPLINGS.

Specification forming part of Letters Patent No. **169,981**, dated November 16, 1875; application filed
August 28, 1875.

To all whom it may concern:

Be it known that I, OSCAR E. FORD, of Meridian, in the county of Lauderdale and State of Mississippi, have invented a new and Improved Car-Coupling, of which the following is a specification:

In the accompanying drawing, Figure 1 represents a horizontal section of my improved car-coupling; Fig. 2, a side view of one of the draw-heads; and Fig. 3, a vertical transverse section on the line *c c*, Fig. 2, of the same.

Similar letters of reference indicate corresponding parts.

My invention relates to an improved automatic car-coupling that may be readily uncoupled from the side and top, and be employed to couple cars of different heights. It consists of draw-heads with forward-projecting parts, which are recessed at their inner sides, and provided with laterally-sliding spring-acted jaws that interlock by the entering of the projecting parts of the draw-heads into the space formed by the shorter part.

In the drawing, A represents a draw-head of my improved coupling, which draw-head is made at one side with a forward-extending part, A¹, and at the other side with a shorter part, A², that forms an L-shaped space between the same, into which the longer part of the interlocking draw-head of the next car enters. The longer part A¹ is recessed at the inner side, the recess *a* being widest at the rear, narrowest at the middle, and tapering and gradually enlarging at the front of part A¹. At the narrowest point of the recess part A¹ is perforated for the laterally-sliding and spring-acted jaw B, that is guided by the perforation and an arm or standard, *b*, attached to the outside of part A¹. The spring-acted jaw B slides as far as a shoulder, *a'*, allows, being operated by a chain, *d*, and L-shaped lever *e* fulcrumed to the end of the platform, or by a fulcrumed lever-rod from

the top or side of the car, or in any suitable manner, so that on withdrawing the jaw the cars may be uncoupled at any moment.

When the cars approach each other the projecting jaws of the draw-heads are guided along the tapering front recesses, and then along their rounded-off front parts sidewise of each other, one jaw pressing the other back until their passage is completed, when the springs carry the jaws forward for coupling, while the shorter side parts A² of the draw-heads prevent the separation of the draw-heads by binding on the longer parts A¹.

The draw-heads are thus firmly connected without chance of getting detached, while the jaws have play in vertical direction by the widening of the recesses *a* at the rear part, which allows the coupling of cars of different heights.

If the draw-heads should also be capable of being connected by the common pin-and-link coupling, they may be provided with cavities *f* and pin-holes *f'* back of the L-shaped space, as indicated in the drawing.

Having thus described my invention, I claim as new and desire to secure by Letters Patent—

1. An automatic car-coupling composed of draw-heads with projecting side parts forming an L-shaped space, and provided with laterally sliding and interlocking spring-jaws, substantially in the manner and for the purpose set forth.

2. The L-shaped draw-head provided with a recess at the inner side of the forward-extending part, said recess being widest at the rear part, narrowest at the jaw part, and tapering at the front part for guiding and retaining the jaws, substantially as specified.

OSCAR E. FORD.

Witnesses:

F. G. HENDERSON,
R. J. MOSELEY.