

A. JACKSON.

MACHINE FOR OPERATING DERRICKS.

No. 169,996.

Patented Nov. 16, 1875.

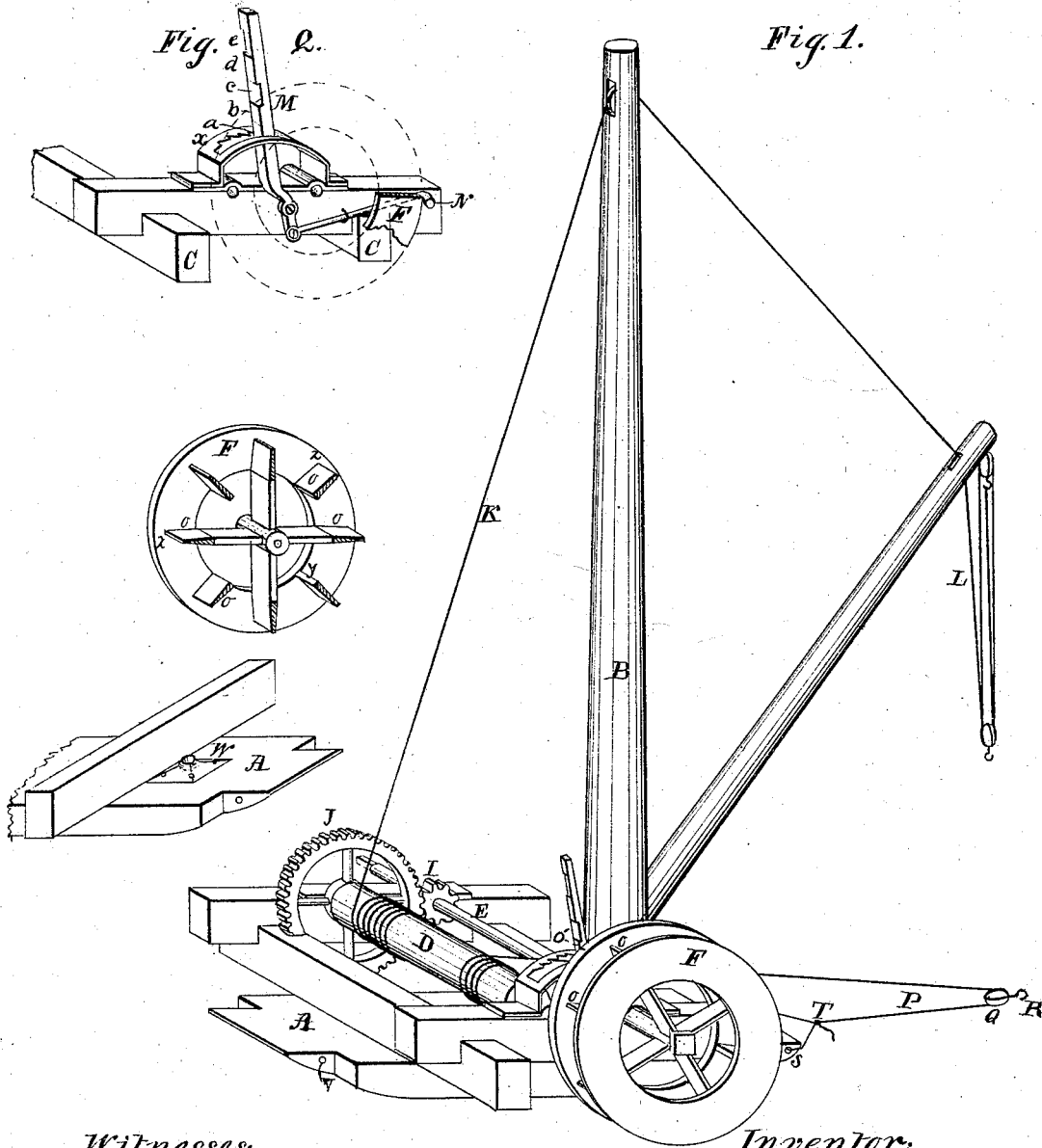

Witnesses:

Abel Jackson
Edw. ...

Inventor:

Andrew Jackson

UNITED STATES PATENT OFFICE

ANDREW JACKSON, OF MOHAWK VALLEY, CALIFORNIA.

IMPROVEMENT IN MACHINES FOR OPERATING DERRICKS.

Specification forming part of Letters Patent No. 169,996, dated November 16, 1875; application filed May 22, 1875.

To all whom it may concern:

Be it known that I, ANDREW JACKSON, of Mohawk Valley, in the county of Plumas and State of California, have invented a new and useful Machine for Operating Hoisting-Derricks; and I do hereby declare that the following is a full, clear, and exact description of the construction and operation of the same, reference being had to the accompanying drawings, making a part of this specification, in which—

Figure 1 is a perspective view. Fig. 2 is a section detached from the balance of machine to more clearly show different parts.

In Fig. 1, A is a sill, on which is pivoted or stepped the mast of crane B. C is a frame, firmly bolted to the sill. On the side pieces of the frame are firmly fixed the windlass-drum D and the crank-shaft E. To either end of crank-shaft may be attached the water-wheel F, which is driven by a jet of water from a hydraulic washing-nozzle. The wheel, being revolved, gives motion to the drum through pinion I and spur-gear J, and thus winds on the rope K, which is a part of the hoisting-tackle L. M is a brake, pivoted to the side of frame in such a position that the hook N will press against the widened rim O of the driving-wheel F, and thus hold the load suspended by pushing back the arm M. This is more clearly illustrated in Fig. 2. P is device employed in conveying the derrick from one place to another, the entire machine and crane being easily moved without taking down the crane. This is done by attaching the block Q to some object of sufficient resisting force, as a tree, a stump, or drill driven in the bed-rock, as shown at R; then the rope P is passed through the block Q, one end then passed through aperture S of sill A, and tied, as shown at T. The other end of rope P is carried to drum D, and there made fast. The rope K is then detached from drum. A crank is then placed on shaft E, by turning which the machine is moved in the direction of R, carrying with it the foot of mast B, and it is only necessary to adjust the guys of the crane, as occasion requires, that the whole thing may be conveyed to any place required. V is an aperture, in which the rope is inserted when it is desired to move the machine in the opposite

direction, or convey the machine the other end foremost. W is a socket, fixed on sill A to hold the foot of mast or pivot in proper position.

In Fig. 2 is shown side piece of windlass-frame C, with ratchet X for holding on brake. The brake has two arms, M and N, the arm M being kept in nearly a vertical position, and near the side of the water-wheel, so that the jet of water may be instantly diverted from the wheel when it is desired to hold the load suspended, and placed against the brake-arm M, which is constructed, first, with a face, *a*, suitable for engagement with the ratchet X; secondly, a face, *b*, standing at right angles to the line of the jet; thirdly, a face, *c*, somewhat inclined toward the wheel and from the ratchet; fourthly, a face, *d*, standing at same angles as face *b*; fifthly, face *e*, with an inclination from the wheel and to the ratchet. In Fig. 2 is also shown a sectional view of the water-wheel F, which is constructed with eight radial paddles or floats, paddles with both sides the same shape, very thin at outer edge, thick enough to give sufficient strength at inner edge or base, tapering in straight lines from inner to outer edge, as shown at Y. The rims of the water-wheel are extended beyond the paddles, or some distance farther from center of wheel, as shown at Z, to prevent the water from spattering about when discharged from wheel, and to force it to go straight forward in almost a solid body, thus securing a considerable washing effect at the same time the derrick is being operated. One of the rims of wheel at its outer edge is widened or flanged, to provide a surface for the brake to operate on. This is shown at O', Fig. 1. The sill A is sloped or beveled at the ends, to facilitate dragging or sliding it over the ground.

This machine may be operated by any of the nozzles in use for hydraulic mining. Its operation is as follows: The device P being removed, and everything properly adjusted, the block and tackle L is hitched to whatever it is desired to hoist. The man whose business it is to manage the nozzle in its gravel-washing turns the jet from the gravel-bank to the water-wheel, which immediately acquires a rapid motion. The rope K is wound on drum D, and the load hoisted. As soon as

the load is sufficiently elevated the man controlling the nozzle diverts it from the wheel to the brake-arm M. If the pressure is great, he applies it to face *b*; if not great, to face *d*, which forces back arm M, and draws forward arm N, causing hook or shoe to press against friction-surface O. Then the jet is directed to face *e*, which, being oblique, causes the water to glance or bound off sidewise, the reaction of which forces the arm M to engage with the ratchet X, and the jet is again sent to the bank to perform its work there. The crane is revolved on pivot at W, turning freely without changing or moving the operating machine. The load is tripped and deposited where wanted, and the man at the nozzle is again called on, and he turns the jet again to the arm M. This time he applies it to face *e*, which is oblique, but is inclined opposite to face *c*, and forces the water to react in such a way as to disengage arm from ratchet, and thus throw off the break, and the jet is again turned to the bank.

It will be seen that in this device the hoisting-crane with its entire weight, and also that of its load, is made to rest on the same sill the

operating machine is attached to, thus causing the machine to be firmly held to its place by the gravity of the object it is operating on. This is a very important part of this invention, especially when we consider the advantages it affords when it becomes necessary to reset or move the derrick.

Having thus described my invention, what I claim as new, and desire to secure by Letters Patent, is—

1. The sill A, with beveled or sloped ends, socket W, for pivot of the crane, the crane and windlass, both arranged on the same sill.

2. The water-wheel F, with friction-surface or widened rim for the brake, the rims extending farther from center of wheel than the paddles Y, paddles of similar shape on both sides, and thin at outer edge, as shown.

3. The brake with the arm M, having two right angles and two oblique faces, as herein shown.

ANDREW JACKSON.

Witnesses:

ABEL JACKSON,
E. CULVER.