

H. A. KIMBALL.

COMBINED UNIVERSAL LATHE AND BELT-SAW.

No. 169,998.

Patented Nov. 16, 1875.

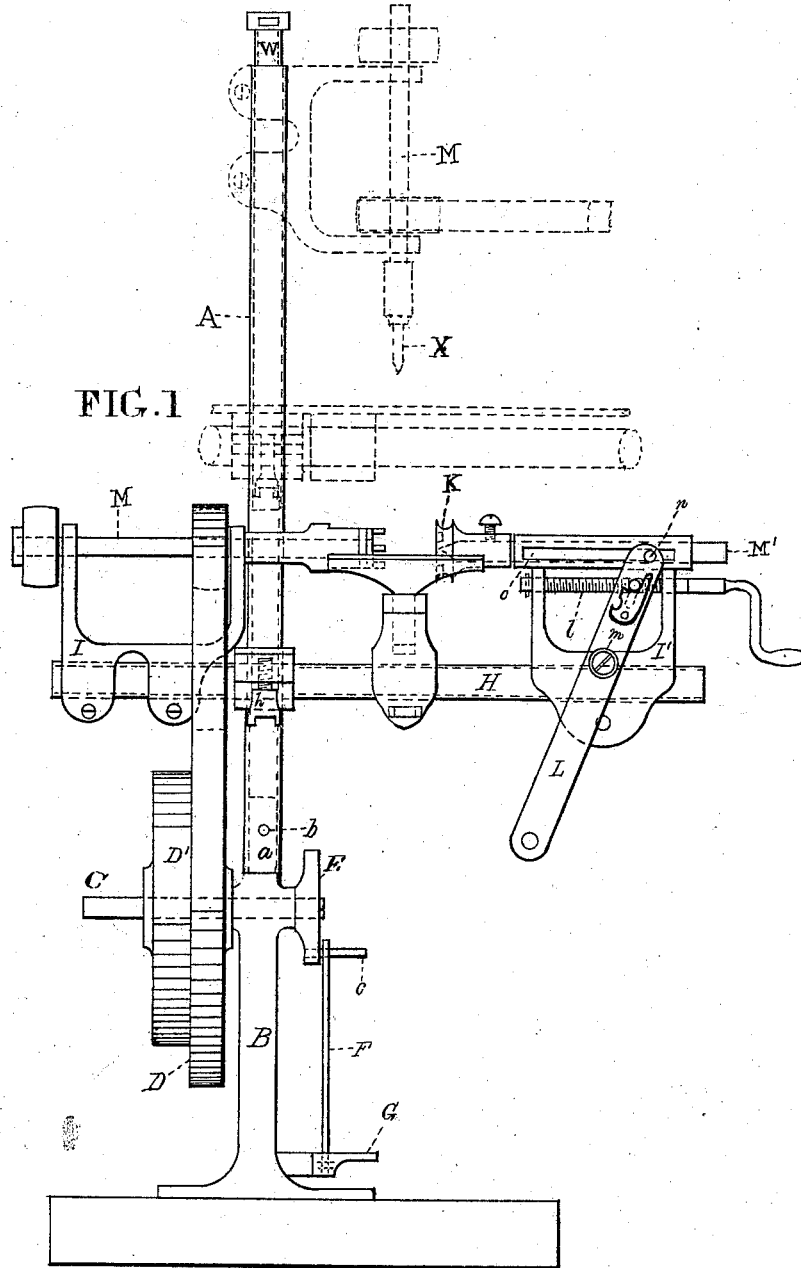

FIG. 1

Witnesses

Thomas G. Dewley
Joseph S. Chahoon

Inventor

Hiram A. Kimball
Stephen W. Ustick Attorney.

H. A. KIMBALL.
COMBINED UNIVERSAL LATHE AND BELT-SAW.
No. 169,998.
Patented Nov. 16, 1875.

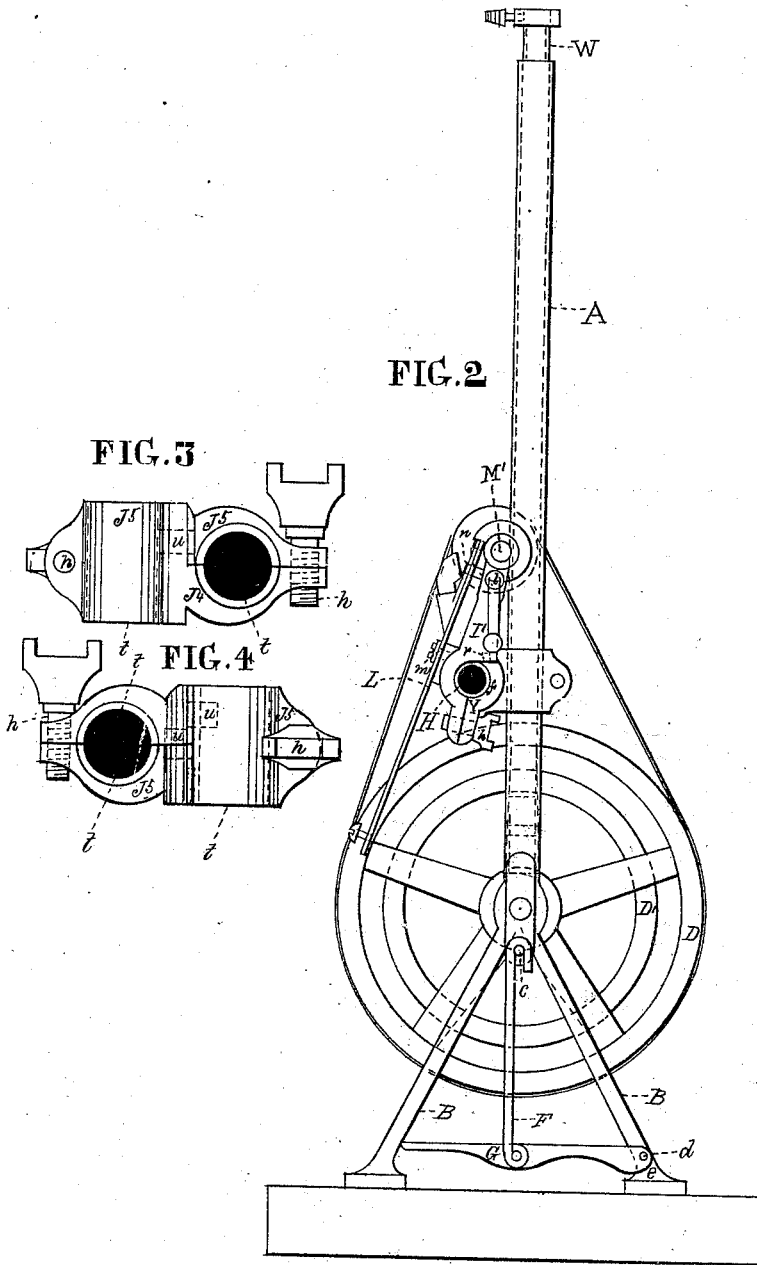

Witnesses.
Thomas J. Dwyer
Joseph S. Mahony

Inventor.
Hiram A. Kimball
Stephen Wotick Attorney

H. A. KIMBALL.

COMBINED UNIVERSAL LATHE AND BELT-SAW.

No. 169,998.

Patented Nov. 16, 1875.

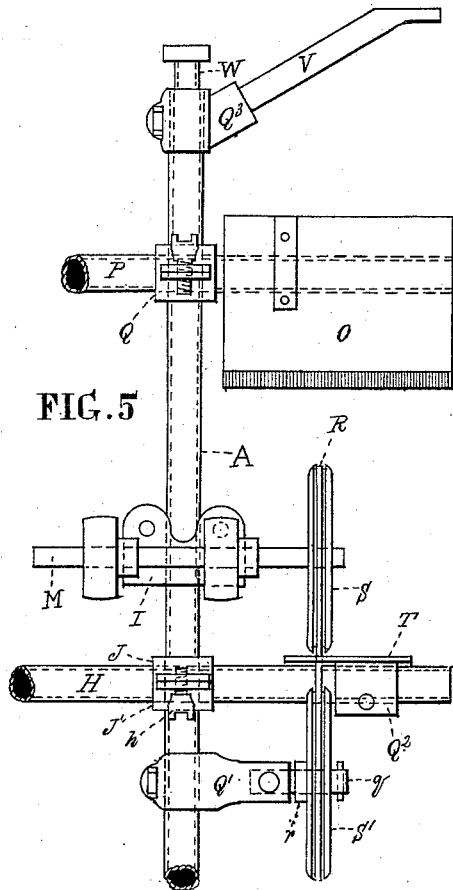

FIG. 5

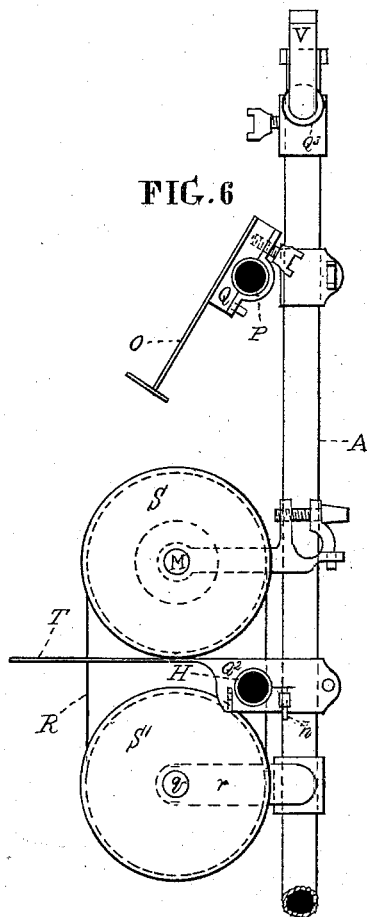

FIG. 6

FIG. 7

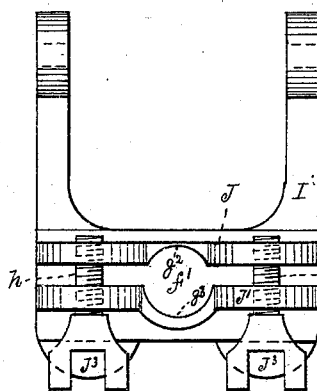

FIG. 8

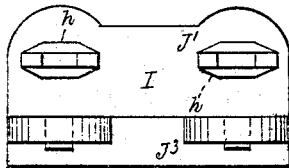
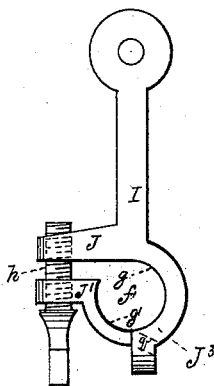

FIG. 9

Witnesses

Thomas Dewley

Joseph Strahorn

Inventor.

Hiram A. Kimball

Stephen Wick Attorney

H. A. KIMBALL.

COMBINED UNIVERSAL LATHE AND BELT-SAW.

No. 169,998.

Patented Nov. 16, 1875.

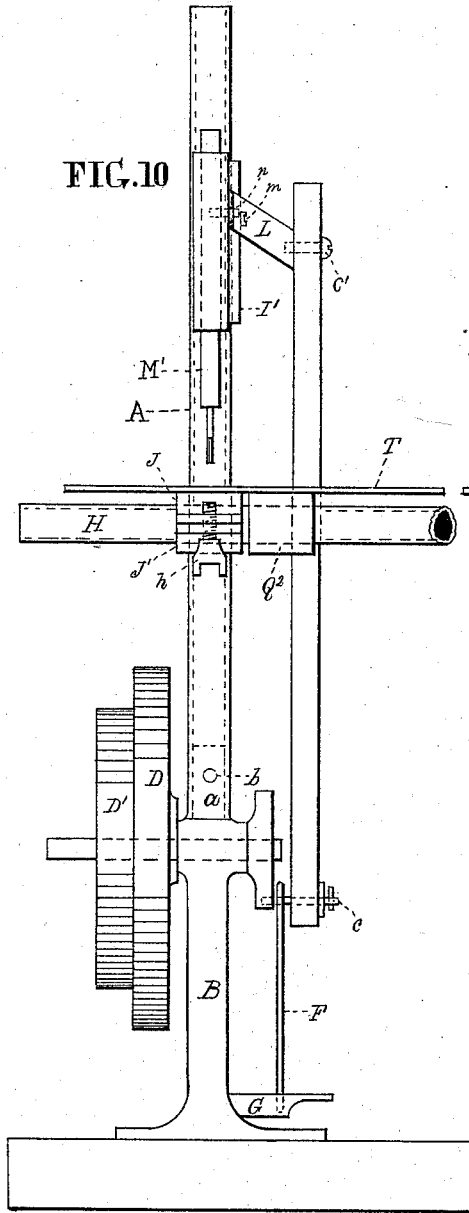

FIG. 10

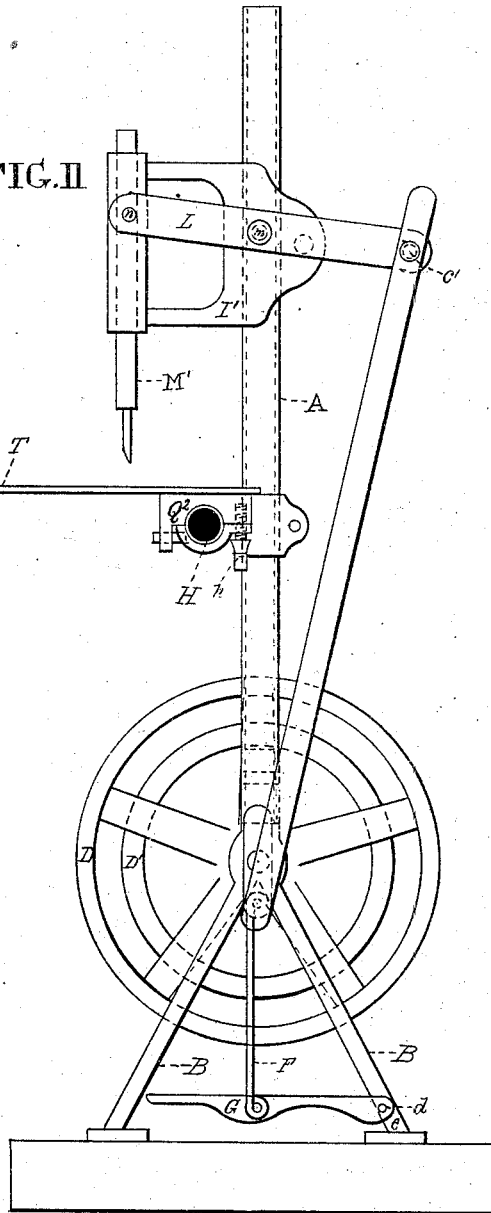

FIG. 11

Witnesses

Thomas C. Dewey
Joseph S. Mahoon

Inventor

Hiram A. Kimball
Stephen W. Stick Attorney

UNITED STATES PATENT OFFICE.

HIRAM A. KIMBALL, OF PHILADELPHIA, PENNSYLVANIA.

IMPROVEMENT IN COMBINED UNIVERSAL LATHES AND BELT-SAWS.

Specification forming part of Letters Patent No. **169,998**, dated November 16, 1875; application filed June 26, 1875.

To all whom it may concern:

Be it known that I, HIRAM A. KIMBALL, of the city and county of Philadelphia, in the State of Pennsylvania, have invented a Combined Universal Lathe and Belt-Saw, of which the following is a specification:

My invention consists in the construction of the lathe, &c., by a combination of clamps and tubes, substantially as hereinafter described.

In the accompanying drawings, Figure 1 is a front elevation of a lathe on my improved plan. Fig. 2, Sheet No. 2, is an end elevation of the same. Figs. 3 and 4 are views at right angles to each other of the clamp for connecting the shears H with the standard A. Fig. 5, Sheet No. 3, is a front elevation of the upper part of the standard A, having a belt-saw, R, and tool-shelf in connection therewith. Fig. 6 is an end view of the same. Figs. 7, 8, and 9 are views, at right angles to each other, of the standing head I of the lathe. Fig. 10, Sheet No. 4, is a front view of a mortising-machine. Fig. 11 is an end view of the same.

Like letters of reference in all the figures indicate the same parts.

A is a tubular standard for the support of the various parts of the lathe, and the other machines which are interchangeably connected with it. B is a triangular base, with which the lower end of the standard A is connected by means of the upright projection *a* of the base and the confining-pin *b*. Instead of the base being of triangular form, as represented in the drawings, its form may be varied at pleasure. C is the wheel and treadle shaft, which has its bearing in the base B. On one end of the shaft is the band-wheel D, which also serves for a fly-wheel. On the same end there is another band-wheel, D', of smaller size, to give a lower speed. The other end of the shaft C is provided with a crank, E, having a wrist-pin, *e*, for the connection of the upper end of the connecting-rod F, the lower end of which connects with the treadle G. The rear end of the treadle is hung on the pin *d*, which passes through cheeks *e e* of the rear foot of the base B. H is a tubular shear for the support of the standing head I and poppet-head I'. The standing head I has two sockets, *f* and *f'*, at right angles to each other. The first is formed of the permanent jaws J J, hav-

ing curves *g g*, which fit the shear H, and the clamping plate or jaw J¹, having a curve, *g*¹, as seen in detail in Figs. 7, 8, and 9, and pins *q* at its end, which fit corresponding holes in the jaw J³, as shown clearly in Fig. 8. The other socket, *f'*, is formed in like manner by the curve *g*² of the permanent jaw J³, and the curve *g*³ of the said jaw J¹. The screws *h h* confine both sets of clamping-jaws. The socket *f'* is for a purpose hereinafter described. The poppet-head I' has a socket, *f'*, only, which is constructed in like manner as the socket *f* of the head I, for its connection with the shear H. The cap Y has a pin which fits a corresponding hole in the standing part of the head, to assist in clamping the head upon the shear. By this mode of connecting the heads with the shears they are readily adjusted so as to have their centers in line; and the poppet-head is quickly changed to the position required to bring the tools of the manifold tool-holder K, which is connected with the mandrel M' of the head in line with the mandrel M of the standing head I. The mandrel M' is operated by means of the parallel screw-rod *l*, having its bearings in the poppet-head, as seen in Fig. 1, and working in a screw-socket at the rear side of the lever L, which is hung on the fulcrum-pin *m*, and is connected at its upper end with the mandrel by means of the pin *n*. The mandrel-socket *o* is cut away on its front side, as represented, to admit of the reciprocating movement of the lever. This mode of giving the movement to the mandrel is adopted for the purpose of using the lever L in the treadle-movement of the mortising-machine, as hereinafter described. The shear H is connected with the standard A by means of duplicate clamps having parts J⁴ and J⁵, seen in Figs. 3 and 4, which have bearings *t* at right angles to each other to fit the standard A and shear H. Each part 5 has a pin, *u*, which fits a corresponding hole in the opposite part 4. The jaws of the clamps are drawn toward each other upon the standard and shear by means of the screws *h*. O is a tool-shelf connected with the horizontal rod P by means of the clamp Q, or in any other convenient manner. The rod is connected with the standard A by means of the double clamp J J¹. It is held firmly in its position, and is adjustable at any

desirable height on the standard A, by loosening the screw *h*. (Seen in Fig. 6.) I connect the belt-saw R with the standard A by detaching the lathe standing head I from the shear H and connecting the hole or socket *f'* with the standard, as seen in Figs. 5 and 6. Then the grooved wheel S is connected with the end of the mandrel M, and the lower grooved wheel S', which is on the stud-pin *g* of the arm *r*, is placed below it, the arm being connected with the clamping-piece Q¹, which is secured to the standard, and is adjustable thereon, in accommodation to the extent of the saw. The saw-table T, by means of the clamp Q², is secured to the tube H, which serves to connect it with the standard by means of the double clamp J J¹, and it is thereby adjustable to any desired height. The table serves also for a bed-plate of a mortising-machine, shown in Figs. 10 and 11, in which the poppet-head I' is placed on the standard, and the upper end of the connecting-rod F connected with the free end of the lever L by means of the wrist-pin *e'*, and the lower end of the rod with the wrist-pin *e* of the crank E, the pin *n'* of the screw-socket being turned out of the slot *x* of the lever. It also serves for a bed-plate of a boring or drilling machine, as represented by dotted lines, Fig. 1, in which the standing lathe-head I is connected with the standard A by the same clamping-jaws which confine it to the shear H, as shown by full lines in the same figure. X is the drill connected with the mandrel M.

In Figs. 5 and 6, V is a brace for holding the upper end of the standard A firmly in position. It is connected with the standard by means of the angular clamp Q³, and is adjustable thereon to suit the height of the ceiling or timber to which its end is connected. W is a tube which passes down the bore of the standard A. Its upper end is brought against the ceiling, and is held firmly in position by tightening the clamp Q³, which also holds both braces

securely, the upper end of the standard being slotted to admit of its being clamped tightly on the tube W.

By making the permanent standing part of the machine to consist of the standard A and base B, as shown, and making the standard and shears of tubing, and connecting the other parts therewith by means of clamps, as above set forth, so as to be used interchangeably, and some of the parts for different purposes, as will be readily seen, it is simply and cheaply constructed, and the interchanging quickly effected by means of the clamps.

I claim as my invention—

1. For clamping together tubes or rods at right angles to each other, a double clamp, shown in Figs. 3 and 4, having parts J⁴ and J⁵, with bearings *t t* at right angles to each other, the parts J⁵ having pins *u*, which fit corresponding holes in the part J⁴, substantially as above set forth.

2. The combination of the tubular shear H, double clamp J J¹, and standard A, for the purpose set forth.

3. The standing head I, having two curved bearings, *f f'*, at right angles to each other, and a clamping plate or cap with two corresponding bearings, whereby the head may be connected with a tube or rod either parallel or at right angles thereto, substantially as and for the purpose set forth.

4. The poppet-head I', having a single clamp, shown in Fig. 8, in which the cap J¹ has a pin, *r*, at one end, and is confined by means of a screw at the other end, substantially as set forth.

5. The combination of the rod P, clamp Q, and double clamp J J¹ with the standard A and adjustable shelf O, for holding the latter in its adjusted position, as set forth.

HIRAM A. KIMBALL.

Witnesses:

THOMAS J. BEWLEY,
STEPHEN USTICK.