

W. S. LANEY.

PUMP.

No. 169,999.

Patented Nov. 16, 1875.

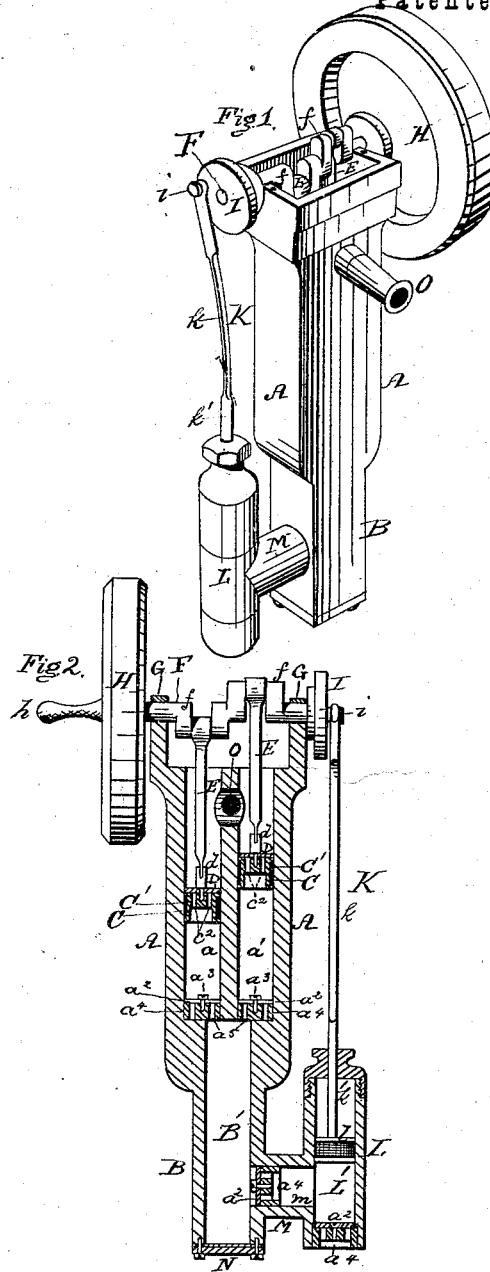

Witnesses:

F. B. Townsend,
Colborne Brookes

Inventor:

William S. Laney
Per Robt. A. Lacey

UNITED STATES PATENT OFFICE.

WILLIAM S. LANEY, OF LITHOPOLIS, OHIO.

IMPROVEMENT IN PUMPS.

Specification forming part of Letters Patent No. 169,999, dated November 16, 1875; application filed September 7, 1875.

To all whom it may concern:

Be it known that I, WILLIAM S. LANEY, of Lithopolis, in the county of Fairfield and State of Ohio, have invented certain new and useful Improvements in Pumps; and I do hereby declare that the following is a full, clear, and exact description thereof, which will enable others skilled in the art to which it pertains to make and use the same, reference being had to the accompanying drawing, and to the letters of reference marked thereon, which form a part of this specification.

My invention relates to an improved combined force and lift pump, particularly adapted for raising water from deep wells, or to a great elevation above the level of the water, the nature of which will be fully explained by reference to the drawings, in which—

Figure 1 represents a perspective view, and Fig. 2 a vertical section, of a combined force and lift pump constructed according to my invention.

In each of the views similar letters are employed to indicate corresponding parts wherever they occur.

A represents the main casting or frame of the combined pump, in which are formed two cylinders, $a a^1$, the lower ends of each of which are in communication with a passage, B' , formed in a pipe or tube, B, connected to or forming part of the lower end of the casting or framing A. The cylinders $a a^1$ are each provided at their lower ends with circular valves $a^2 a^2$, affixed centrally by means of screws a^3 over a cylindrical seat, a^4 , formed with a series of perforations, a^5 , arranged in a ring around the center of the seats a^4 , in position to be opened or closed by the valves a^2 . C C are a pair of pistons working in the cylinders $a a^1$. These pistons C C are formed cylindrical, and at their upper ends are provided with heads C' , which are perforated at c^2 , and provided with circular valves D, which are held in place by bearings d , screwed into the ends of the pistons C. To each of the bearings d , by a pin-joint, is attached the lower end of a connecting-rod, E, the upper end of which is formed so as to embrace one of the cranks f of a crank-shaft, F, mounted so as to revolve in bearings G, formed on or affixed to the upper edge of the casting A, the upper half of the bearings G, in Fig.

1, being removed in order to show the remainder of the device more clearly. On one end of the shaft F is mounted a fly-wheel, H, provided with a suitable handle, h , or a driving-wheel, for the purpose of operating the pump, while at its opposite end the shaft F is fitted with a disk or crank, I, to the pin i of which is connected a piston-rod, K, the central portion k of which is so formed as to be resilient, while its lower end k' is rigid and cylindrical, and is attached to the piston l of a force-pump, L, which consists of a cylinder, L' , in which the piston l works, and a pair of valve-seats, a^4 , and valves $a^2 a^2$, opening in opposite directions, as shown by Fig. 2. The valve-seats a^4 of the cylinders a, a^1 , and L' are each formed cylindrical, and turned so as to fit sufficiently close to the cylinders, that they shall not be moved or become displaced in the working of the apparatus, but are so fitted that they may any time be capable of removal or replacement for repairs or cleaning of the valves. The piston-cylinder L' is connected to the lower end of the pipe or tube B by means of a tube, M, the passage m of which is regulated by means of the valve a^2 , which is arranged to open from the cylinder L' into the pipe or tube B. The lower end of the pipe or tube B is closed by means of a plate or cover, N, while the lower end of the cylinder L' is open to or is provided with a suitable pipe or tube, connecting with the water in the well or tank from which the water is to be raised.

The operation of the device is as follows: The shaft F being caused to revolve, the cranks f and I will, by means of the connecting-rods E and K, cause the pistons C C and l to be moved alternately up and down in their cylinders, by which means water will be first caused to rise into the force-pump L, and from thence be driven into the cylinders $a a^1$, from which it will be lifted by the pistons C C, and caused to flow away into a suitable tank or receiver by means of a pipe or spigot, O.

Having thus described my invention, I would have it understood that I do not claim, broadly, a combined force and lift pump; but

What I do claim, and desire to secure by Letters Patent, is—

A combined force and lift pump, embodying in its construction a pair of cylinders, $a a^1$,

formed in a single casting or framing, A, and provided with removable perforated seats a^4 , valves a^2 , and pistons or plungers C C, and an external force-pump, L, having removable perforated seats a^4 , valves a^2 , piston l , and a resilient piston-rod, k , the plungers C C and piston l being operated by a revolving crank-axle, F, substantially as shown and described.

In testimony that I claim the foregoing as my own I affix my signature in presence of two witnesses.

WILLIAM S. LANEY.

Witnesses:

J. V. LEE,

F. F. D. ALBERY.

W.S. Laney