

E. D. AVERELL.

MACHINES FOR GATHERING THE SIGNATURES OF BOOKS.

No. 180,103.

Patented July 25, 1876.

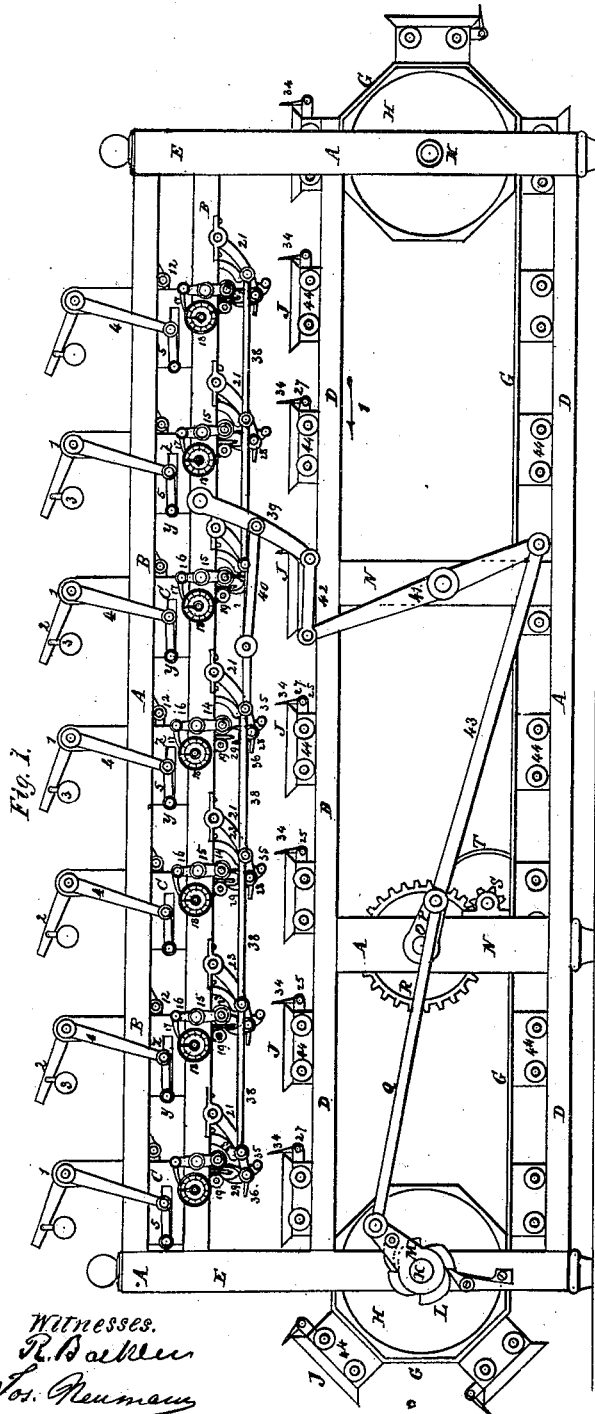

Witnesses.
R. D. Walker
Jos. Neumann

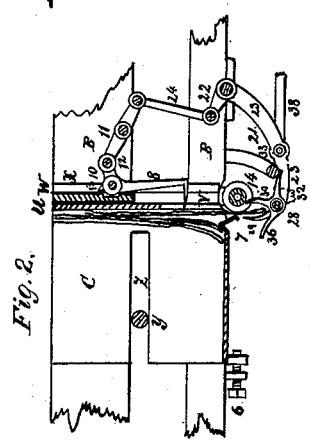
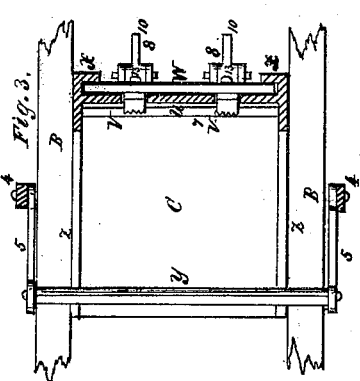
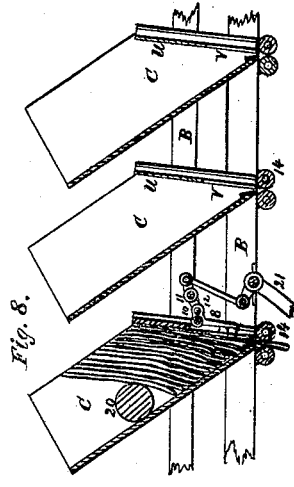

Inventor
E. D. Averell

E. D. AVERELL.

MACHINES FOR GATHERING THE SIGNATURES OF BOOKS.
No. 180,103. Patented July 25, 1876.

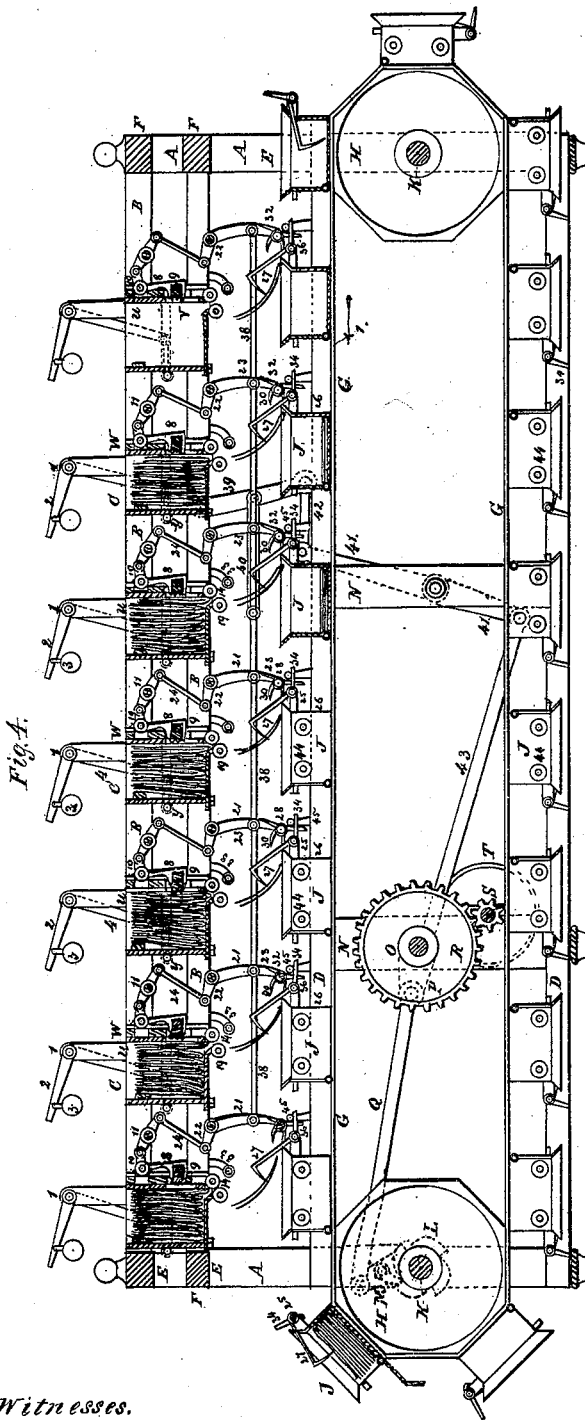

Fig. A.

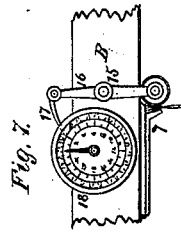

Fig. 7.

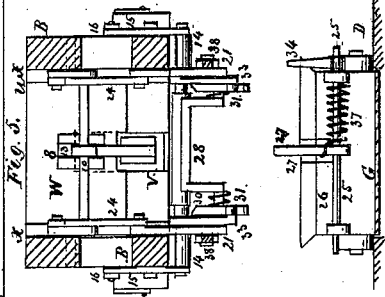

Fig. 5, 6.

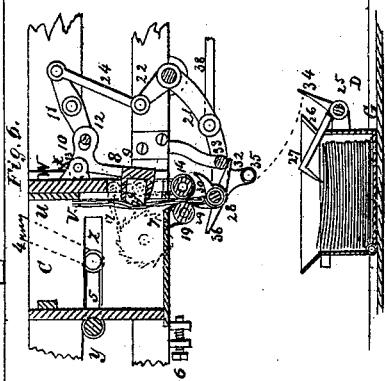

Fig. 8.

Witnesses.
R. Boellner
Jos. Neumann

Inventor.
E. D. Averell

UNITED STATES PATENT OFFICE.

ELLCOTT D. AVERELL, OF BROOKLYN, NEW YORK.

IMPROVEMENT IN MACHINES FOR GATHERING THE SIGNATURES OF BOOKS.

Specification forming part of Letters Patent No. **180,103**, dated July 25, 1876; application filed October 28, 1875.

To all whom it may concern:

Be it known that I, ELLCOTT D. AVERELL, of the city of Brooklyn, in the county of Kings and State of New York, have invented a new and useful Machine for Gathering the Several Signatures of Books, which is fully set forth in the following specification, reference being had to the accompanying drawings:

The object of this invention is to collect or gather properly the several asignatures or characters of a book, ready for stitching and binding the same, by means of a combination with the several receptacles containing the several kinds of the signatures for a book, and each provided with a device for picking each signature separately therefrom, of a gathering or collecting band or carrier, or travelers, passing said receptacles successively, and of a device for feeding and transferring each signature automatically from said receptacles to said travelers, carriers, or band, and of a device for controlling and registering the delivery of each signature from said receptacles. By these means the gathering of the signatures for books is done with mechanism instead of by hand, and is done consequently with less labor, less hands, more rapidly, and more reliably than by hand, or the manner heretofore used or known.

In the drawings, Figure 1 represents a side elevation of a machine for gathering the signatures according to my invention. Fig. 2 is a detached longitudinal vertical section of one of the signature receptacles or boxes, with its mechanism for picking each signature separately, and transferring the same to the carrier or collecting box or band of the same. Fig. 3 is a horizontal section of the same. Fig. 4 represents a vertical longitudinal section of the entire machine. Fig. 5 is a detached vertical cross section of the upper part of the machine. Fig. 6 is a vertical longitudinal section of the same. Fig. 7 is a detached face view of one of the alarm and registering devices of the machine. Fig. 8 represents a detached longitudinal vertical section of a modification of the signature-boxes of the machine.

To enable others skilled in the art to make and use my invention, I will proceed to describe the machine, or one of the modes by which I carry out my invention.

In this machine I construct a narrow, long frame, (represented by the letter A.) Between four upper side rails, B B B B, two on each side of said frame, I arrange, at equal distances apart, a sufficient number of stationary signature boxes or receptacles, C C C C, of which each contains a certain kind of the same signatures, as delivered from the printing or folding process in the manufacture of books. The several kinds of signatures required for a certain portion, or the complete book, are one of each kind detailed to each box C, of which there is the requisite number to receive all the signatures for the book, and said several kinds are detailed successively in said boxes, so that by collecting one signature from each of said boxes in the direction of the arrow 1, (shown in Figs. 1 and 4,) and placing in the same order upon one another, the desired book is collected, with its signatures properly arranged. The lower and middle part of said frame has each a longitudinal rail, D, on each side of the frame, which are combined with the rails B B by means of the vertical posts E E at the ends of the frame, as shown; and said posts are combined by cross-pieces F F at the upper and lower portion of said frame. The rails D D project inwardly, or between the sides of the frame, and between said sides are arranged the drums H H, over which an endless band, G, passes.

Upon the periphery of said band are arranged and secured a series of movable gathering or collecting carriers or boxes, J, for containing the gathered signatures. The drums H are arranged one on each end of the frame. Their periphery is eight-cornered, and their shafts K K revolve in bearings secured to the end posts E E of the frame. Said collecting-boxes J are secured upon said band the same distance apart as the boxes C above. The shaft K of one of the drums H has on each of its ends, projecting outside the frame, a fixed ratchet-wheel, L, and a loose pawl-lever, M, with a pawl to engage in the teeth of said ratchet-wheel; and the frame A has also several posts or uprights, N, on each side, connecting the upper rails D with the lower. To one of the said posts N are secured bearings, through which a horizontal cross-shaft, O, passes, which has on its ends, projecting outside the frame, a crank, P, on each, arranged

in line with the other, and said cranks have each a connecting-rod, Q, attached to the crank-pins of it, which connected rod has its opposite end pivoted to the outer end of said pawl-lever M, to operate it; and upon the portion of the said shaft O between the sides of said frame is secured a spur-gear wheel, R, which engages in a pinion-gear mounted correspondingly on a secondary cross-shaft, S, located below said shaft O, in bearings on the same posts N N. Said cross-shaft S is the driving-shaft of the machine, and has a loose and fast pulley, T T, on its outside end, and for driving the same. The cranks P have a sufficient stroke to move the pawl-lever M, and consequently the drums H and band G and the boxes J, at each revolution of said crank or cross-shaft O, the distance from the one of the boxes C to the succeeding box. The forward side U of each of the said boxes C has one or more vertical slots, V, and has a slide, W, arranged before it, which moves vertically, and is held to it by means of a vertical strip, X, on each side, secured to the front of the box, and overlapping the ends of said slide. The rear side of each of said boxes C is made low, and has a cross-bar, Y, secured on the central portion of its back, as shown in Fig. 6. Said cross-bar projects through the sides of said box C, of which each has a horizontal slot, Z, through it for guiding said bar and rear side, and allowing them to slide to the forward side, and thereby feeding the signatures, which are located vertically in the box, as shown, between the rear and forward side as rapidly as drawn out and discharged from the box. To cause said rear side to press the signatures forward, I employ over, and a distance above, each box C a horizontal cross-shaft, 1, with a rearwardly-projecting arm, 2, and on said arm a small weight, 3, on each of the outer ends of said cross-shaft 1 a long downward arm, 4, and connect said arms with the outer ends of the cross-bar Y by means of links 5, so that by this means the weight 3 presses the cross-bar and rear side to the forward side.

The cross-shaft 1 is held in bearings extending from the top rails B upward above the box C. Said cross-bar Y may be used without the rear side to act directly upon the signatures, or it may have vertical strips or springs secured to it. The bottom of the box C is made detached from the sides of the box, and is made to slide thereon, so that its end on the forward side can be more or less withdrawn therefrom, and thereby permit a narrow space between sufficiently wide to allow one of the signatures operated upon to pass readily through said space. By means of set-screws 6, acting upon the end of the bottom, said bottom is readily adjusted with the desired space between it and the front side.

The forward end 7 of said bottom is made inclined, as shown, to cause the edge of the signature to straighten, to pass readily through the space for its discharge.

The slide W has on its front side one or more vertical feed-levers, 8, pivoted to it, which are furnished each with a rubber pad, 9, passing through the slot V in the front side of the box. The levers 8 have from their fulcrum or pivot, with which they are attached to the slide W, a short arm, 10, extending forward horizontally; and said short arm 10 of each of said levers is connected with a two-armed lever, or a pair of two-armed levers, 11, by means of a pivot or a pivot-rod, 12, which passes through a slot in said short arm. Said two-armed levers 11 vibrate on their fulcrum. They are moved as hereinafter shown, and cause the movement of the slide W through the lever or feed-levers 8. It will be noticed that whenever the arm of the lever 11, connected with the arm 10, moves upward, the long arm of the feed-lever with the pad 9 first moves outward away from the front side of the box, and from the signature in contact with it. As soon as the stop 13 on the hub of the lever 8 meets the slide W, the slide is obliged to move up with the lever 8 until the lever 11 has terminated to move up. Said lever thereafter, in moving downward again, first turns the feed-lever, and causes its pad to engage, through the slot V, the signature in contact or close to the front side. It causes said signature to move down and pass through the space for it between the front side and the end of the bottom until the movement downward of the lever 11 has terminated, and thereafter said pad 9 withdraws again from the signature, and finally causes the slide W to move up, as before described, from the upward movement of said lever 11.

For narrow boxes and signatures one feed-lever may be sufficient to use, as shown in Fig. 5; but for wide signatures, and in most cases, two or more of the levers 8 are employed, as shown in Fig. 3.

Instead of employing several levers, 8, one of them may be employed, having several pads, 9, and the front side has always the corresponding number of slots V to allow the pads 9 to pass through.

Close under the end of the front side of each box C is employed a roller, 14, which is nearly opposite the inclined edge of the bottom. Said roller extends along the opening left by the bottom of the box, and its bearings are in the lower arms of the levers 15, of which one of each is pivoted to each side of the lower rail B. (Shown in Figs. 7 and 6.) Said roller, by its own weight, hangs close to said end of the bottom, thereby keeping the opening for the signature to pass out closed; but as soon as the edge of the signature is forced down, the inclined portion of the bottom end comes in contact with said roller, said roller is caused to move out to turn its levers 15, and allow the signature to pass.

The levers 15 have a secondary arm, 16, upward from their fulcrum, which arm has a pawl, 17, pivoted to it, and said pawl engages in the teeth of a gear in a register, 18, so that,

by the signature, the roller 14 and the levers 15, and consequently the register, are moved, and thereby each signature is registered and shown on the dial of the register.

In certain cases, or in operating upon certain kinds of signatures, it may be preferable to have, instead of rubber pads on the levers 8, sharp points or needles to engage the signature and feed it, as shown in Fig. 2; or the pads may have both rubber and points combined to engage the signatures. It may be preferred, in many cases, to reduce the friction of the edge of the signature in passing the edge of the bottom of the box. In such case I provide, opposite the roller 14, a secondary parallel roller, 19, which has stationary bearings on the lower part of the box, as shown in Figs. 1, 4, and 6.

With certain kinds of signatures it may be preferable to have the end of the bottom beyond its inclined end made with a short rising portion, as shown in Fig. 2, so that the edges of the signatures are held back before arriving on the inclined portion.

In constructing the machine for large numbers of signatures it may be preferable to make the boxes C inclined, as shown in Fig. 8. In such case the weight 3 and appendages for pressing the signatures forward may be dispensed with, and a simple roller, 20, or other weight, may be employed to press the signatures forward.

From the above is shown how the most forward signature in each box C is separated and drawn down to project a short distance below the roller 14, as shown in Figs. 1, 2, 6, 8, and 7. The carriers or collecting-boxes J at this time of the motion of the machine are yet stationed below the respective boxes C, from which they have been before collecting; and, in order to transfer the signatures from their partly-down advanced position, I employ the transferring-levers 21, which have their fulcrum-bearing in the lower rail B, and have each two arms, 22 and 23. The arm 22 of each is short, and is connected by means of a link, 24, with the forward arm of the lever 11; and the arm 23 is long, and vibrates between the roller 14 and the top of the box J under it. On its outer end are attached the fingers for clamping the lower end of the signature projecting down; and to carry said signature down and over the box J, each of the boxes J has on its rear side 26 a spring-finger, 27, for pressing the signature down on the respective box J. For each box C is employed a pair of said transferring-levers 21, one of each on the opposite sides of the frame, and the lower ends of each pair of said levers 21 are connected by the rod 28, which is stationary or rigid with the levers, and has stationary fingers attached to it. Opposite to said stationary fingers 29 are arranged vibrating fingers 30, which turn on the rod 28 freely, but are caused to close with the sta-

tionary fingers 29 by means of springs 31, and thereby clamp the signature between them.

In order to open said fingers and permit the signature to enter between, I employ each of the fingers 30 with a short arm, 32, and have on the lower rail B secured down-projecting studs 33, which come in contact with said arms 32, and cause their opening, as shown in Figs. 2, 5, and 6. The roller 14 has grooves turned in its periphery to allow the fingers 30 to pass close by said roller.

The spring-fingers 27 are each secured upon a small shaft, 25, working in bearings secured on the rear side of the box J. The outer end or ends of said shaft has a short arm or arms, 34, projecting upward, and the levers 21 have each a projecting stud, 35, to come in contact with said arms 34; and the fingers 30 have also short arms 36 opposite their arms 32, to come in contact with the shafts of the spring-fingers 27 on the boxes J, so that, simultaneously with the transferring-levers 21 receding and carrying the signature down from the boxes C, the collecting-boxes J moving at this time forward in contrary direction to the movement of said levers 21, the studs 35 are brought in contact with the arms 34, and cause the spring-fingers 27 to turn back out of the way until the levers 21 with their fingers 29 and 30 have properly advanced with the signatures over the boxes J, by which time the short arms 36 have come in contact with the shafts of the spring-fingers 27, and caused the fingers 30 to release the signatures; and nearly at the same time the studs 35 pass by the arms 34 and the springs 37, with which the fingers 27 are provided, causing said fingers to press the signatures into the boxes J. After this operation the levers 21 turn upward again, and the boxes J remain until the levers 21 have again with their fingers taken hold of the signatures, at which time the boxes J proceed as before described.

The motion of the slide W and feed-levers 8 is obtained from the levers 11, which are connected with the levers 21, and obtain their motion from them. The levers 21 are all connected together by means of the rods 38. The rods 38 are connected with vertical levers 39 on each side of the frame, and pivoted to the lower rails B B, and connected by means of links 40; and said levers 39 are on their lower end connected with a secondary pair of vertical levers, 41, one of each pivoted to each side of the lower part of the frame, and said connection is made by the links 42. Said secondary levers 41 have each two arms, one above and one below their fulcrums. The upper arms are connected by said links 42 to said levers 39; and the lower arm of each is connected with one of the cranks P on the shaft O by means of a rod, 43, so that the same cranks, P, which operate the drums H, band G, and boxes J, also operate the transferring-levers 21 and feed-levers 8; and while the

pawl-levers M are turning back for a new hold, the levers 21 turn back to take hold of the signatures, and at this time the feed-levers forward the signatures for the transferring-levers.

The machine is always constructed with a sufficient number of boxes, C, to contain, if not all the kinds of signatures for a complete book, a considerable number of them.

If a book is required to be gathered with less kinds of signatures than the number of boxes C of the machine, the surplus boxes, either on the rear end or forward end of the machine, are left empty.

To have the boxes J to rest properly and steady during their passage under the boxes C, I provide each with a pair of rollers, 44, on its sides toward the side frames, and make the rails D to project under said rollers. Instead of using the studs 35, it may be preferred to have studs 45 secured and properly located upon the top side of the upper rail D, to operate the spring-fingers 27. The same studs may also operate the fingers 30 instead of the ends of the shaft 25, as shown in Fig. 4. Each box J, after having passed the signature-boxes and made the collection of a book, arrives, finally, upon the rear drum H, and while remaining there, as shown in Fig. 4, the operator opens the front side, which is hinged to the bottom, and removes the collected book, and thereafter the operator closes said front side again, which has a spring-hook or a latch, or other locking device, for keeping closed.

The boxes J may not be used, and the transferrers or transferring-levers 21 may deliver the signatures directly upon the band G. The transferring-levers may be substituted by endless cords receiving the signatures between and carrying them to the band G. However, I prefer to use said boxes J and levers 21, on account of the certainty with which the operation is performed.

The object of the registers is to control the operation of the machine, so that as soon as one signature has missed to be discharged, the operator is able to discover the fact, to stop the machine, and correct the missing signature in the respective box J before the book is delivered.

With said register is also connected a small alarm device, which is set in motion by the non-action of the register at the time of the signature being forwarded by the feeding device. Said alarm may also be set in motion by assistance of an electric device.

What I claim, and desire to secure by Letters Patent, is—

1. The combination, with the receptacles or boxes containing the several kinds of sig-

natures for books, of a device, substantially as described, for picking each signature separately, and a gathering-band, chain travelers or carriers passing said receptacles, to collect successively the signatures from said receptacles, substantially as and for the purpose herein described and shown.

2. The combination of the boxes C with the boxes J, the transferrers or levers 21, and feed-levers 8, substantially as and for the purpose herein stated.

3. The combination of the boxes C with the feed-levers 8, and slides W, and the rollers 14, and device for registering, substantially as and for the purpose set forth.

4. The combination of the band G and boxes J, the drums H, the ratchet-wheel L, and cranks P, substantially as and for the purpose set forth.

5. The combination of boxes J, having hinged forward sides, with the fingers 27, to operate substantially as and for the purpose herein stated.

6. The combination of boxes C, having adjustable bottoms and yielding rear sides, with the pads 9, to operate substantially as and for the purpose herein shown and described.

7. The combination of the bottom of the box C with the roller 14, and the fingers 29 and 30 and the feed-lever 8, substantially as and for the purpose herein mentioned.

8. The combination of the boxes C, the slide W, the levers 8, with the pads 9, the levers 11 and 21, the studs 33, and rollers 14, and fingers 29 and 30, substantially as and for the purpose herein set forth.

9. The combination of the cranks P, the levers 41, and levers 39, the links 42 and 40, and rods 38, the levers 21, links 24, levers 11, and feed-levers 8, and slides W, substantially as and for the purpose herein stated.

10. The combination of the band G with the boxes C, the feed-levers 8, and transferrers 21, substantially as herein set forth.

11. The combination of the boxes C, the feed-levers 8, and carriers-J, substantially as herein stated, and for the purpose set forth.

12. The combination of the pad 9, feed-lever 8, and box J, substantially as herein set forth.

13. The combination of the feed-levers 8 and friction-pads 9 with the slides W and the roller 14, to operate upon the signature, substantially as and for the purpose herein described.

In witness whereof I hereunto set my hand this 27th day of October, 1875.

ELLCOTT D. AVERELL.

In presence of—

R. BOEKLEN,
JOS. NEUMANN.