

H. GUELS.
MACHINE FOR MAKING CAR SEALS.
No. 180,124. Patented July 25, 1876.

Fig. 1

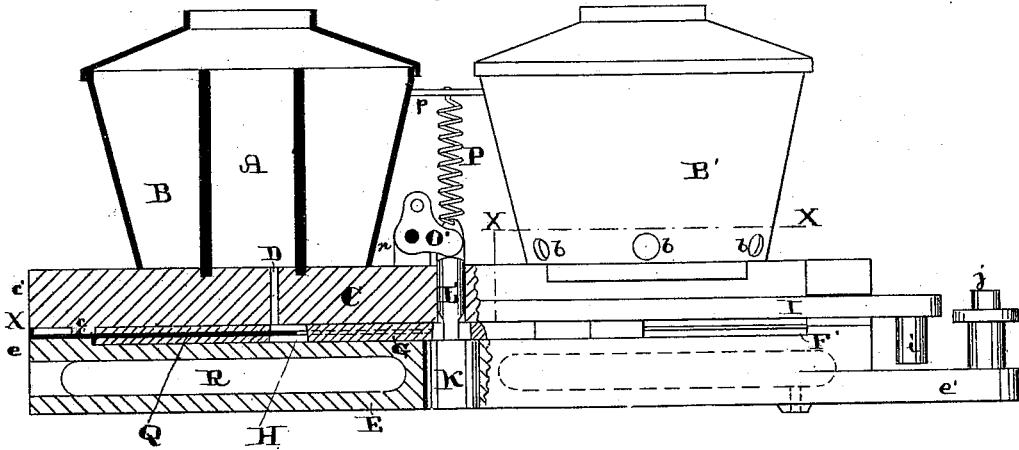
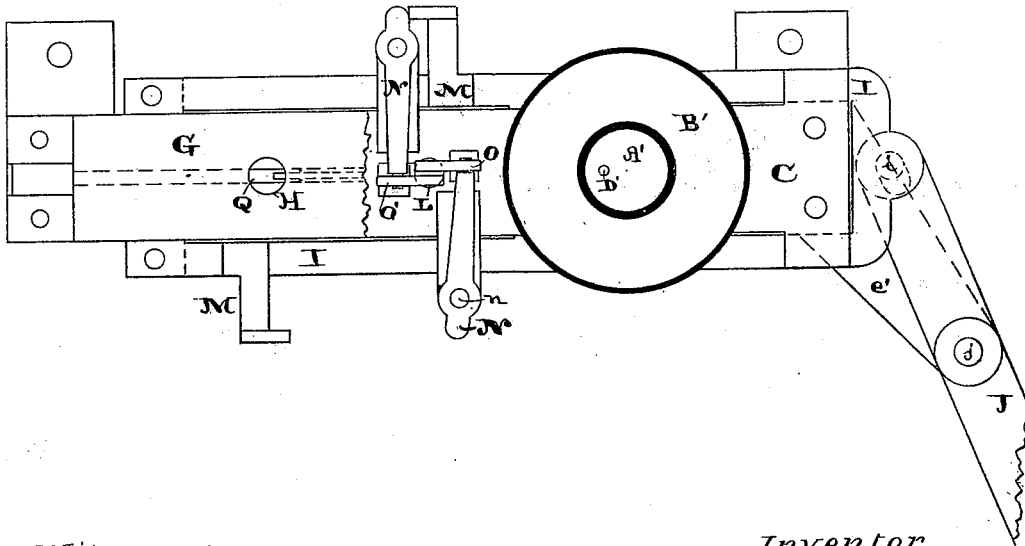

Fig. 2
X. X.



Witnesses

Saml. S. Boyd
David Lewis

Inventor

Herman Guels,
by Chas. D. Moody
atty.

H. GUELS.
MACHINE FOR MAKING CAR SEALS.
No. 180,124. Patented July 25, 1876.

Fig. 3

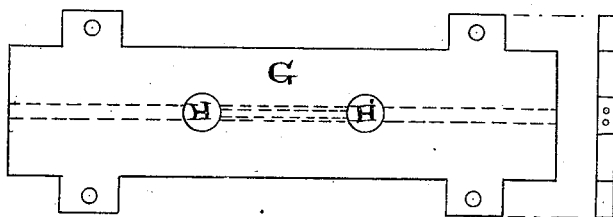

Fig. 4

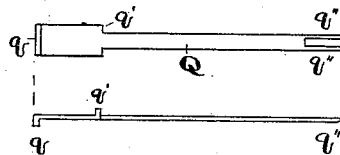

Fig. 5

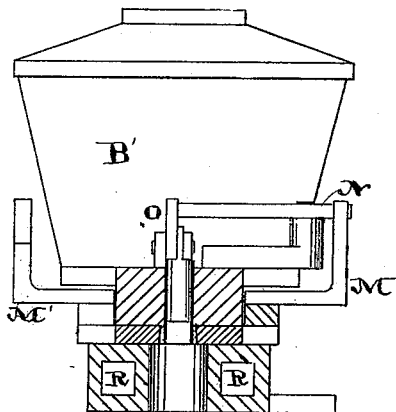
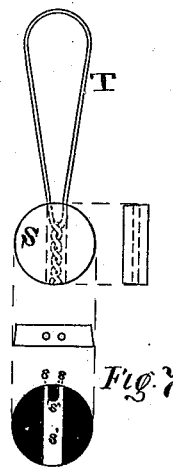
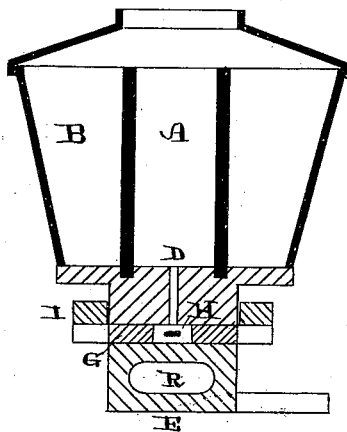

Fig. 6



Witnesses.

Saml. S. Boyd
Daniel Lewis

Inventor.

Herman Guels
by Chas. D. Mosby
att'y

UNITED STATES PATENT OFFICE.

HERMAN GUELS, OF ST. LOUIS, MISSOURI.

IMPROVEMENT IN MACHINES FOR MAKING CAR-SEALS.

Specification forming part of Letters Patent No. 180,124, dated July 25, 1876; application filed May 5, 1876.

To all whom it may concern:

Be it known that I, HERMAN GUELS, a resident of St. Louis, Missouri, have invented a new and useful Improvement in Machines for Making Car-Seals, of which the following is a full, clear, and exact description, reference being had to the annexed drawings, making part of this specification, in which—

Figure 1 is a view of the invention, partly in vertical longitudinal section, and partly in side elevation; Fig. 2, a horizontal section taken on the line *x x* of Fig. 1; Fig. 3, a plan and cross-section of the slide; Fig. 4, a plan and elevation of the core; Fig. 5, a vertical cross-section, showing the mechanism for ejecting the seal from the slide; Fig. 6, a vertical cross-section taken through the furnace; and Fig. 7, views showing my improved seal, and the manner of attaching the wire thereto.

Like letters indicate like parts.

The present invention relates to an improved machine for making car-seals. By means of it, also, an improved seal can be produced. In its general construction it consists of a furnace where the metal of which the seal is formed is kept in a fluid condition, and from which it is drawn off into a mold beneath. The mold is contained in a slide which has a horizontal reciprocating movement, and after the seal has been cast it is carried in the slide to a suitable point, where it is ejected from the slide. The latter is then returned to its original position, and the operation is repeated. Suitable means are employed during the casting for forming the perforation in the seal, and for cooling the slide and surrounding parts.

Referring to the annexed drawing, A represents a reservoir or furnace, where the metal of which the seals are formed is held in a molten condition. The metal is previously melted elsewhere, but to keep it from chilling in the furnace the latter is surrounded by a fire-chamber, B. The furnace and fire-chamber rest upon a base, C. A passage-way, D, leads from the furnace downward through the base C. There is a sub-base, E, which supports the entire structure, and in the following manner: At each end of the base E, and on its top, is a projection, *e e*; at each end of the part C, and on its bottom, is a projection,

c c. The last-named projections rest upon the projections *e e*. In this way a space is provided between the part C and the sub-base E. In this space, F, a slide, G, is arranged to move, and as is hereinafter described. The slide is shorter than the space; but, in respect to its thickness, is made to fit snugly therein, and operating as a cut-off at the lower end of the passage D to prevent the descent of the molten metal, saving as is hereinafter explained. H represents an opening in the slide, and extending vertically through the same. This opening is the mold wherein the seal is cast. The slide is made to have a reciprocating movement in the space F. To effect this the slide is connected with a yoke, I, which in turn is moved in a reciprocating manner by means of a lever, J. The lever is pivoted at *j* to a projection, *e'*, of the base, and is connected with the yoke at *i*. When the seal is cast the slide is arranged as in Fig. 1, and so as to bring the opening H beneath the passage D. To remove the seal from the mold the slide, by means of the lever, is moved, so as to bring the mold over an opening, K, in the base E. A plunger, L, is then caused to move downward, and to strike the seal down through the opening K.

The mechanism for actuating the plunger is as follows: A stop, M, on the yoke I (in the movement of the latter) is caused to strike a lever, N, arranged horizontally and pivoted at *n* to the part C. The lever N moves a bell-crank lever, O, which presses downward upon the plunger. The latter is raised by means of a spring, P, that is hung from a support, *p*, above, or, if preferred, a counter-weight can be used. To form the perforation in the seal a core, Q, is used. This is shown in Figs. 1, 2, 4. It is of suitable width and thickness, and, in length, long enough to extend from the outer end *e'* of the part C inward through and past the mold H, when the latter is in position to receive the metal. The outer end of the core is provided with a flange, *q*, to keep the core from being drawn in too far with the slide G in the movement of the latter, and so that its inner end might interfere with the ejection of the seal from the mold. The core, toward its outer end, is further provided with another flange, *q'*, to prevent the core

from being thrust too far out from the machine by the return movement of the slide, and so as to bring it into a position where it could not act as a core when the second seal is made. The flanges are suitably spaced apart, and arranged to effect these ends, and in the movement of the core, they encounter, respectively, the outer and inner sides of the projections *c e*. The inner end of the core is forked. For an ordinary seal the core is so constructed and arranged as to extend the forks *q'' q''* entirely across the mold during the casting, and, by means thereof, to form two perforations extending entirely through the seal.

To form my improved seal the core is constructed and arranged so as to bring a portion of the shank and the inner ends of the forks in the mold during the casting, and as shown in Figs. 1 and 2. The base *E* is preferably made hollow, as shown at *R*, Fig. 1, to enable the lower part of the device to be cooled by means of a water circulation therein.

The construction thus far described relates to but a single furnace and mold. I preferably employ a double construction. Accordingly, I make another furnace and fire-chamber, *A'* and *B'*, and arrange them similarly upon an extension of the part *C*, and beyond the mechanism for ejecting the seals from the mold. There is a similar passage, *D'*, leading downward, to convey the metal from the furnace *A'* into a duplicate mold, *H'*, in an extension of the slide *G*. The various parts are so proportioned and arranged as to enable the casting to be carried on alternately at either end of the machine; and while a seal is being cast in one of the molds *H'* the seal previously cast in the mold *H* is being ejected from the latter—that is, the slide carries the seal formed in either mold to above the opening *K*, and beneath the plunger *L*. The ejecting mechanism is suitably duplicated. The molten metal is kept properly warm in the furnace by means of a fire in the chamber *B*, to which air is supplied through the apertures *b b*, &c. It thence flows into the mold *H*, where it surrounds the core, but is prevented from falling through the mold because of the base coming against the slide. The latter is then moved to carry the seal to beneath the plunger. There is danger, however, of the collapse of the top of the seal if the core is withdrawn too quickly. Therefore, and, preferably, by means of friction arising from the metal adhering slightly to the core, I contrive to draw the latter along a little way with the

slide, and until the flange *q* encounters the projection *c* or *e*. This gives the metal time enough to set before it is off the core.

My improved seal *S* is shown in Fig. 7. Instead of being formed with two perforations, *s s*, extending entirely through the seal, as is customary, there is one larger perforation, *s'*, extending part-way, and, preferably, nearly through the seal; and from this perforation *s'* the two perforations *s s* extend the remainder of the way through the seal. *T* represents the wire as attached to my seal. The two ends thereof are passed through the perforations *s s*, and then through the perforation *s'*, and out of the seal. The ends are then twisted and the wire drawn back, bringing the twisted portion into the perforation *s'*. The sides of the seal are then pressed inward, closing the entrance to the perforation *s'*. The wire cannot be drawn in the other direction because of the bridge *s''* between the perforations *s s*.

My machine can be enlarged in capacity by duplicating, in a lateral direction, the parts where the casting is done—that is, the slide can be enlarged and additional molds can be arranged side by side. A single furnace, however, can be used to supply all the molds.

What I claim is—

1. The combination of the furnace *A*, part *C*, having the passage *D*, base *E*, and slide *G*, having the opening or mold *H*, substantially as described.
2. The combination of the part *C*, base *E*, slide *G*, yoke *I*, and lever *J*, substantially as described.
3. The combination of the lever *N*, lever *O*, part *C*, and plunger *L*, substantially as described.
4. The combination of the yoke *I*, stop *M*, levers *N* and *O*, part *C*, and plunger *L*, substantially as described.
5. The combination of the slide *G* and core *Q*, having the forks *q'' q''* operating substantially as described.
6. The combination of the core *Q*, having the flanges *q* and *q'*, projection *c*, and slide *G*, substantially as described.
7. The combination of the core *Q*, having the flanges *q* and *q'*, forks *q'' q''*, projection *c*, and slide *G*, having the mold *H*, substantially as described.

HERMAN GUELS.

Witnesses:

DANL. T. POTTER,
CHAS. D. MOODY.