

G. McKAY.

MACHINES FOR UNITING THE UPPERS AND SOLES OF BOOTS AND SHOES.

No. 180,146.

Patented July 25, 1876.

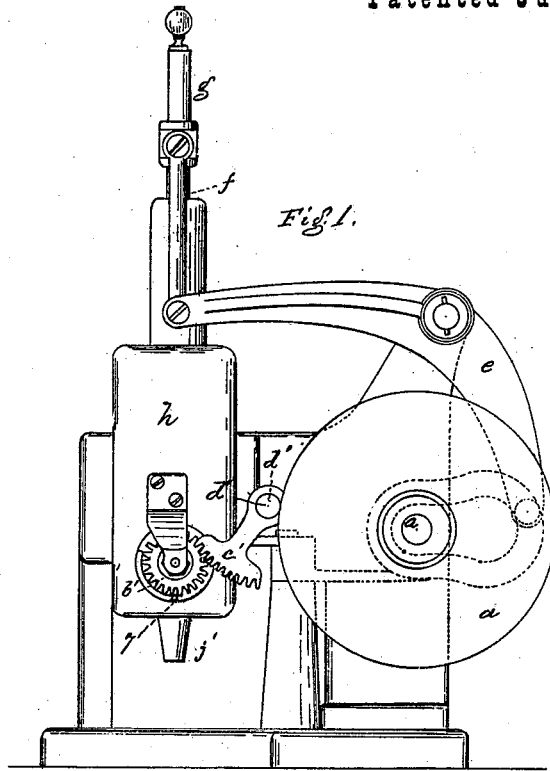

Fig. 1.

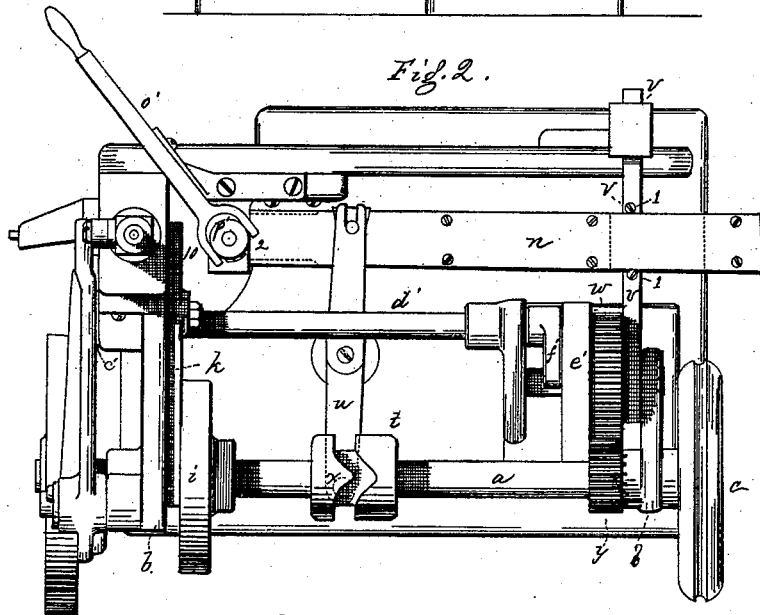

Fig. 2.

Witnesses.

L. H. Latimer.

W. J. Pratt.

Inventor.

Gordon McKay
per Henry Gregory
attys.

G. McKAY.

MACHINES FOR UNITING THE UPPERS AND SOLES OF BOOTS AND SHOES.

No. 180,146.

Patented July 25, 1876.

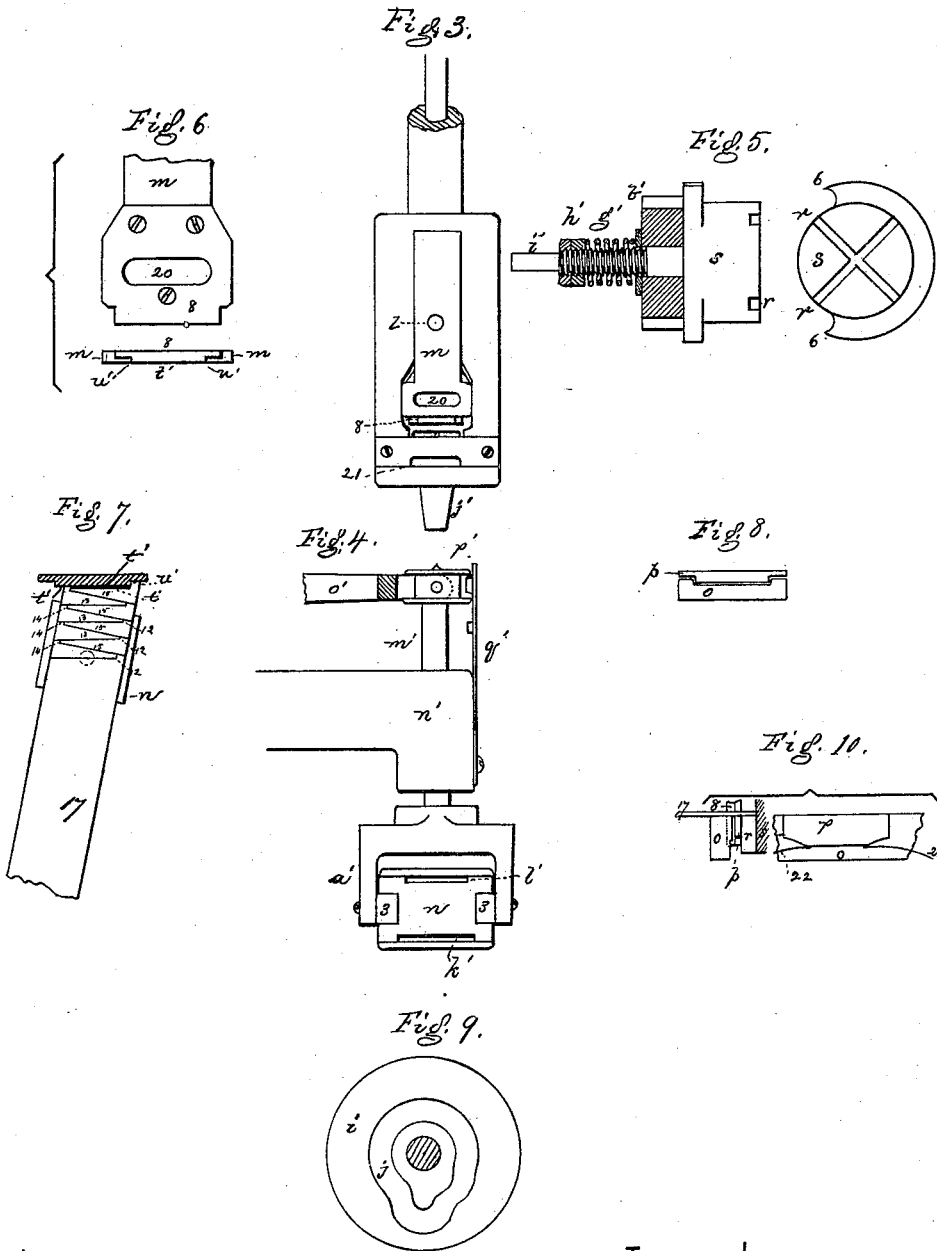

Witnesses.

L. H. Lortimer.
W. J. Pratt.

Inventor.

Gordon McKay
per *Henry Angory*
Atty

UNITED STATES PATENT OFFICE.

GORDON MCKAY, OF CAMBRIDGE, MASSACHUSETTS.

IMPROVEMENT IN MACHINES FOR UNITING THE UPPERS AND SOLES OF BOOTS AND SHOES.

Specification forming part of Letters Patent No. **180,146**, dated July 25, 1876; application filed May 13, 1876.

To all whom it may concern:

Be it known that I, GORDON MCKAY, of Cambridge, in the county of Middlesex and State of Massachusetts, have invented an Improvement in Machines for Uniting Soles to Uppers, of which the following is a specification:

This invention relates to a machine for uniting soles to uppers, and particularly to that portion of a nailing-machine adapted to present a strip to the action of cutters, to sever from the strip at each operation a headed nail, and present it to the action of the driver, the devices for supporting the sole and feeding it over the support being of any usual construction.

This invention consists in a vibrating strip-box, in combination with a punch and a fixed or opposed cutter or die and a carrier, whereby tapering nails are severed from a ribbon-like strip, and are presented by the carrier with their heads uppermost, and in line with the driver; also, in a vibrating strip-box adapted to carry in separate passages nail-strips of different widths, in combination with mechanism to raise and lower the inner end of the strip-box, to bring either a wide or narrow strip into operative position; also, in a carrier actuated by a friction-pinion and sector, or equivalent, and combined with a suitable stop, whereby the carrier may be automatically set in correct working position with reference to the nail-driver and the nail-passage.

Figure 1 represents this improved machine in end view; Fig. 2, a top view; Fig. 3, a rear side view of the head, showing the die or cutter; Fig. 4, a detail of the strip-box lifter; Fig. 5, detail of the carrier for reversing the nails; Fig. 6, a detail of the punch or movable member of the cutting devices; Fig. 7, a nail-strip, showing the manner in which it is cut into nails; Fig. 8, a top view of the fixed cutter and nail-support, and Fig. 9 a face view of one of the disks; Fig. 10, a partial vertical section through the cutting mechanism and carrier, and partial front view.

The main shaft *a*, supported by standards *b b*, is driven by a belt on pulley *c*, or in any other usual way, and is provided with cams and pinions to operate the different devices. The disk *d*, provided with a cam-groove, (shown

dotted, Fig. 1,) moves the driver-lever *e*, connected, by link *f*, with the driver-rod *g*, which it operates in the usual manner, the driver moving in guides in the head *h*. Disk *i* is provided with a cam-groove, *j*, (see Fig. 9,) to operate the lever *k*, that engages a pin, *l*, on and reciprocates the slide *m*, to which is attached the punch or movable member *8* of the cutting mechanism, and moves it, so that it holds the end of the strip while the strip-box moves back a distance sufficient for the width of the nail next to be cut from the strip, the nail-strip then slipping between the usual friction feeding-jaws or holders in the strip-box *n*, and then the further descent of the punch *m* severs the nail between it and the cutter-block *o*, and the nail severed from the strip descends beyond the block *o*, the nail-support *p*, sustained by a suitable spring or springs, *22*, descending with *m* and holding the nail firmly. As the cutter then rises, the support *p* follows it, placing the nail opposite one of the nail-grooves *r* in the nail-carrier *s*, (the groove then to receive the nail being in substantially a horizontal position,) and then the nail-strip box is moved forward by the cam projection *x* of the cam-hub *t*, that vibrates lever *u*, connected at its other end with the strip-box, so as to cause the end of the nail-strip then projecting from the strip-box to strike the severed nail and move it from the support *p* into the groove *r*, after which the strip-box is drawn back to its position farthest from the cutter.

When the strip-box reaches its extreme backward position, its extreme end is moved laterally by means of the slide-rod *v*, provided with pins *1*, to meet the sides of the strip-box, and provided, also, with a friction-roller, that enters a cam-groove cut in the face of a toothed wheel, *w*, engaged and moved by the toothed wheel *y* on shaft *a*. The groove in wheel *w* moves the strip-box laterally, and acts to move the end of the strip-box when it reaches its backward position, first in one, and then at the next time the strip-box comes back it is moved or vibrated in the other direction, the slide-rod at all other times remaining at rest, supporting the end of the strip-box, and permitting the latter to be moved forward and backward, the bar in this instance passing through an elongated slot in the strip-box.

This movement of the back end of the strip-box laterally (its forward end at 2 being supported on ears 3 of a pivoted standard, *a'*) permits the strip-box at its forward end to place the end of the nail-strip in an angular position with relation to the edge of the cutter and punch, inclining the strip first in one and then in the other direction, enabling the mechanism to cut tapering nails with heads, the heads and points being cut alternately from the same edge of the strip without turning it over. This method of cutting leaves half the nails with heads projecting in one and half projecting in the opposite direction; and to reverse or turn the heads of these nails each uppermost, in correct position for the action of the driver, I employ the carrier *s*, having grooves *r*, into which the nails are moved. This carrier is adapted to rotate one-fourth of a revolution, first in one and then in an opposite direction, in substantially the manner described in United States Patent No. 157,929, and the carrier will present the heads of the nails uppermost, the grooves *r*, in their vertical position, coinciding with the usual driver-passage.

The carrier is moved through the action of a toothed wheel, *b'*, engaged by a vibrating sector, *c'*, on a rock-shaft, *d'*, moved, in turn, by a cam-grooved disk, *e'*, a pin on the arm *f'* entering the groove. To prevent the carrier and the devices moving it from being broken when the carrier, for any reason, becomes caught, I have not connected the pinion *b'* positively with the carrier, and only hold it pressed against the carrier by a spiral spring, *g'*, having in connection with it suitable adjusting-nuts *h'*, adapted to move on the screw-rod *i'*, connected with the carrier *s*.

The rim of the carrier is cut away, as shown at the left of the right-hand figure of Fig. 5, thereby forming projections 6, that engage a stop-pin, 7, on the head, and placed with such relation to the driver-passage, grooves *r*, and nail-tube *j'* as to always insure that one groove, *r*, is in line with the driver-passage whenever a projection, 6, meets the pin 7.

Should the carrier not move, being stopped by a nail, or otherwise obstructed, the toothed wheel *b'* will move and prevent breakage of the machine; but the driver will descend, and, striking the solid part of the carrier, may be broken; but such injury may be quickly and cheaply repaired. The nail or obstruction is then removed, and, on starting the machine, the sector, in its movement acting on the wheel *b'*, will immediately and automatically set the carrier in proper position to work in unison with the other parts until again obstructed.

The shifting strip-box is provided, in this instance, with two passages, *k' u'*, for nail-strips of different widths, (but there may be a greater number,) to provide nails of different lengths for different portions of the sole.

The shank *m'* of the pivoted standard *a'* is adapted to slide in a bearing, *n'*, it being moved longitudinally by means of a lever, *o'*,

(in this instance forked at its end 10,) and fitted to a grooved hub, *p'*; and the forward end of the strip-box is retained in position to permit the passage of a nail of the right length, by means of a catch, *q'*, provided with lugs, and adapted to enter the groove in the hub.

It is evident that the movable member of the cutter and the strip-box might be actuated by other devices than those shown without departing from my invention.

The small figure of Fig. 6 shows the lower end of the punch 8, the edge *t'* being toward the strip-box, and the shoulders *u'* act alternately with the edge *t'*, to cut the strip on the lines 12 13, and then on lines 14 15. The corners *u'* cut the strip on lines 12 and 14, to form the under side of the brad-like head of one and the point end of another nail, and the edge *t'* cuts the strip alternately on lines 13 15, according to the direction in which the nail-strip is inclined with reference to the punch 8 and fixed cutters. The fixed cutter is the reverse of the punch, and the portion of the strip to form the head rests, when the punch is lowered, on one of the portions 16 of the cutter.

In Fig. 7 the lines *t' u'* represent the punch. *n* represents a portion of the pivoted strip-box, and 17 the nail-strip, and the lines 12 13 14 15 show the lines in which the strip will be cut to form the brad-like nails.

The strip-box, as herein described and shown, will present the widest strip to the punch and cutter in correct position to cut a headed nail at each descent of the punch; but the narrow strip, when thrown into position to be used, will not present its edge sufficiently far toward the ends of the punch and cutter as to place it in position to permit the corners *u'* to operate and form a head, and, therefore, all the nails cut from the narrow strip will simply be tapering nails without heads. It is obvious, however, that the strip-box may have an extra lateral motion at its forward end when the narrow strip is being used, and then the strip would be moved far enough toward each side the cutter to cut headed nails from the narrow strip. This will form the subject-matter of another application.

The opening 20 permits the passage of the end of the uppermost strip projecting from the strip-box when the lower strip is being used, and opening 21 is for the lower strip when the upper is being used.

The width of the nail may be gaged from the forward end of the nail-strip by an adjustable pin placed at the center of the carrier. Substantially such a gaging-pin is shown in United States Patent No. 169,463.

I claim—

1. In a nailing-machine, the combination, with a punch and cutter, substantially as described, of a vibrating strip-box and a carrier to form tapering nails from a strip, and place them into position, with heads or largest ends uppermost, to be driven by the driver, substantially as described.

2. The stationary cutter and yielding nail-support and punch, in combination with a movable strip-box, whereby the strip is held while the strip-box is moved back far enough to measure off a new nail, and with mechanism to move the strip-box forward to push the severed nail into a carrier, substantially as described.

3. A vibrating strip-box, adapted to carry two or more strips of different widths, in combination with mechanism to raise or lower the forward end of the strip-box, to permit the use of nails of different lengths, substantially as described.

4. The carrier provided with projections 6, in combination with a stop, and with a friction-pinion, and an arm for moving the pinion, and adapted to operate substantially as described.

In testimony whereof I have signed my name to this specification in the presence of two subscribing witnesses.

GORDON MCKAY.

Witnesses:

G. W. GREGORY,
S. B. KIDDER.