

S. P. M. TASKER.  
EXPANDING MANDRELS.

No. 180-169.

Patented July 25, 1876.

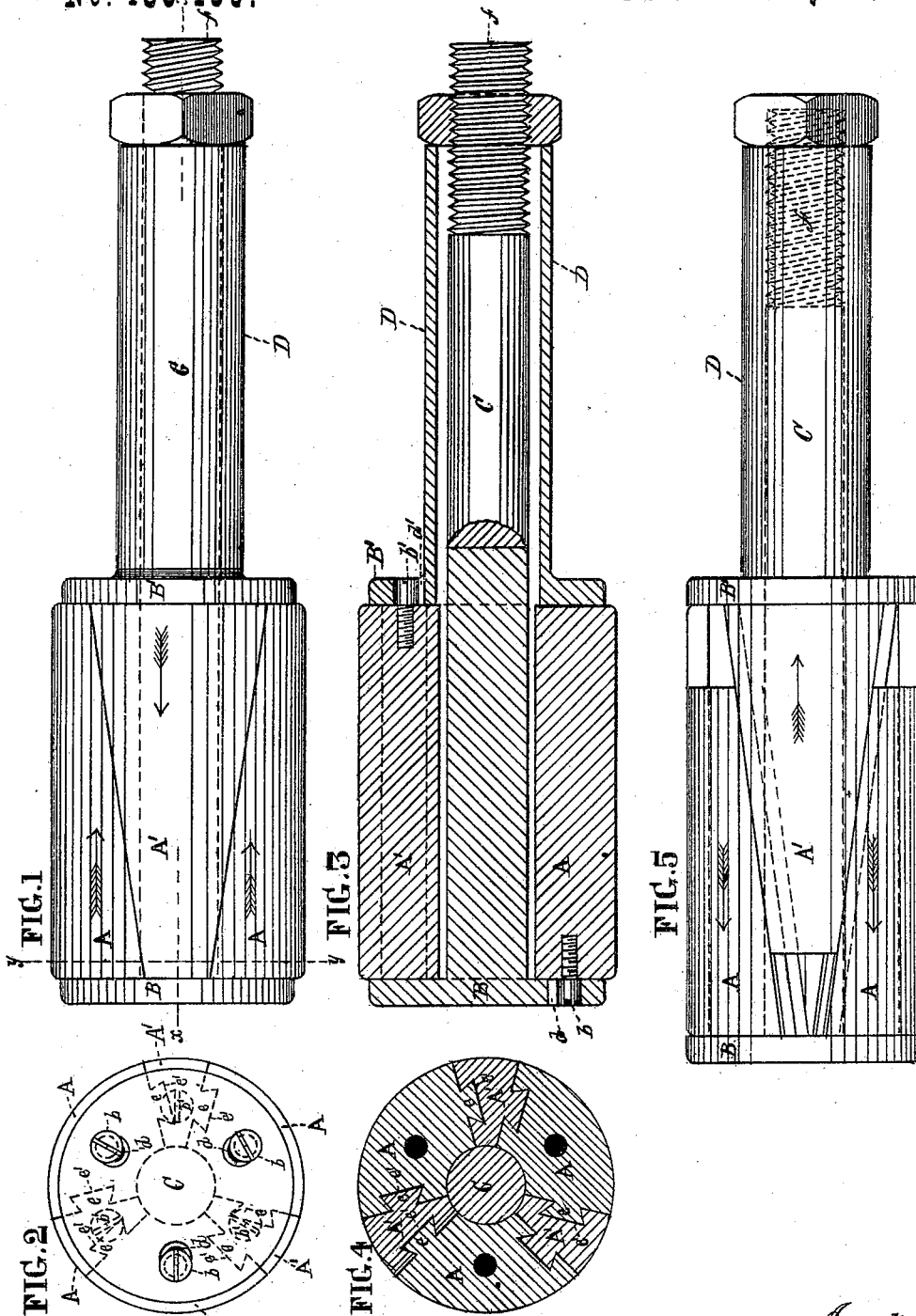

Witnesses  
Thomas J. Jewell  
Isaac Prindle

Inventor  
Stephen P. M. Tasker  
Stephen Utich attorney

# UNITED STATES PATENT OFFICE

STEPHEN P. M. TASKER, OF PHILADELPHIA, PENNSYLVANIA.

## IMPROVEMENT IN EXPANDING MANDRELS.

Specification forming part of Letters Patent No. **180,169**, dated July 25, 1876; application filed June 28, 1876.

*To all whom it may concern:*

Be it known that I, STEPHEN P. M. TASKER, of the city and county of Philadelphia, in the State of Pennsylvania, have invented a new and useful Improvement in Expanding Mandrels, which improvement is fully set forth in the following specification, reference being had to the accompanying drawings.

The nature of my invention consists in the division of the mandrel into tapered longitudinal sections, the wide end of every alternate section being at one end of the mandrel, and the wide end of the intermediate sections at the other end. The edges of the sections are held together and their peripheries kept even by means of male and female dovetails. By the longitudinal movement of one set of sections, whereby the narrow ends of the two sections are caused to approach each other, and the wide ends to recede from each other, the mandrel is contracted in its diameter, and when they are moved in an opposite direction the diameter is expanded. In order to accomplish these results, so as to accommodate the mandrel to different sizes of tubes, I connect the large ends of every alternate section with a flange held thereon by means of screws or pins, which are allowed play in radial slots, the said flange being fast on a central rod. The large ends of the intermediate sections are in like manner connected with a similar flange, which is fast on one end of a central tube or socket. The rod is operated by means of a nut on its outer end, or by a lever or any other suitable device, whereby the mandrel is expanded or contracted in the direction of its length, for the contraction or expansion of its diameter, as hereinafter fully described.

In the accompanying drawings, Figure 1 is a side view of my improved mandrel expanded in its diameter. Fig. 2 is an end view of the same. Fig. 3 is a longitudinal section at the line *x x* of Fig. 1. Fig. 4 is a cross-section at the line *y y* of Fig. 1. Fig. 5 is a side view of the mandrel contracted in its diameter.

Like letters of reference in all the figures indicate the same parts.

A A A are three tapered longitudinal sections of the mandrel, and A' A' A' are intermediate sections of the same form, but in a

reversed position, whereby their narrow ends come between the broad ends of the former. The broad ends of the sections A A A are held against the flange B by means of screws or pins *b*, there being radial slots *d* in the flange to admit of the expansion and contraction of the sections. The sections A' A' A' are connected in like manner with the flange B' by means of the screws *b'*, which pass through the radial slots *d'* of the flange. The sections are held together by means of the male and female dovetails *e e'*, whereby they are permitted to move freely in the direction of their lengths, for the expansion and contraction of the mandrel, and their peripheral surfaces kept at all times even with each other.

C is a central rod, one end of which is permanently connected with the flange B. It has a longitudinal movement in the tube or socket D, one end of which is fast to the flange B'. By the longitudinal movement of the rod in the direction of the arrows seen in Fig. 1, the two sets of sections A and A' having their wide ends drawn nearer each other, the mandrel is expanded in its diameter, as seen in said Fig. 1; and when the rod is moved in the opposite direction, (indicated by the arrow in Fig. 5.) so as to cause said broad ends to recede from each other, the diameter is contracted, as seen in said figure.

To effect the longitudinal movement of the rod C I have a nut, *f*, on its outer end, as represented in the drawing, or else employ a lever or any other convenient device, whereby a like result is produced.

I have shown three sections in each set, but do not confine myself to the use of this number, as two or any higher number may be used.

The combination of the rod C and tube D may be dispensed with by having a rod projected from the outside of each flange B and B', moved in opposite directions.

I claim as my invention—

1. An expanding mandrel having tapered longitudinal sections, held together at their edges by means of male and female dovetails, or other equivalent device, to admit of the longitudinal movement of the sections for the

expansion and contraction of the diameter of the mandrel, substantially as set forth.

2. The combination of the sections A and A', having screws or pins *b b'* in their ends, with the flanges B and B', having radial slots *d d'*, substantially as and for the purpose set forth.

3. The combination of the rod C and tube

or socket D with the flanges B and B' and sections A and A', the rod being operated by means of the nut *f* or other suitable device, substantially as set forth.

STEPHEN P. M. TASKER.

Witnesses:

THOMAS J. BEWLEY,  
STEPHEN USTICK.