

J. VAN LEUNEN.  
SEWING-MACHINE BINDERS.

No. 180,177.

Patented July 25, 1876.

FIG. 1.

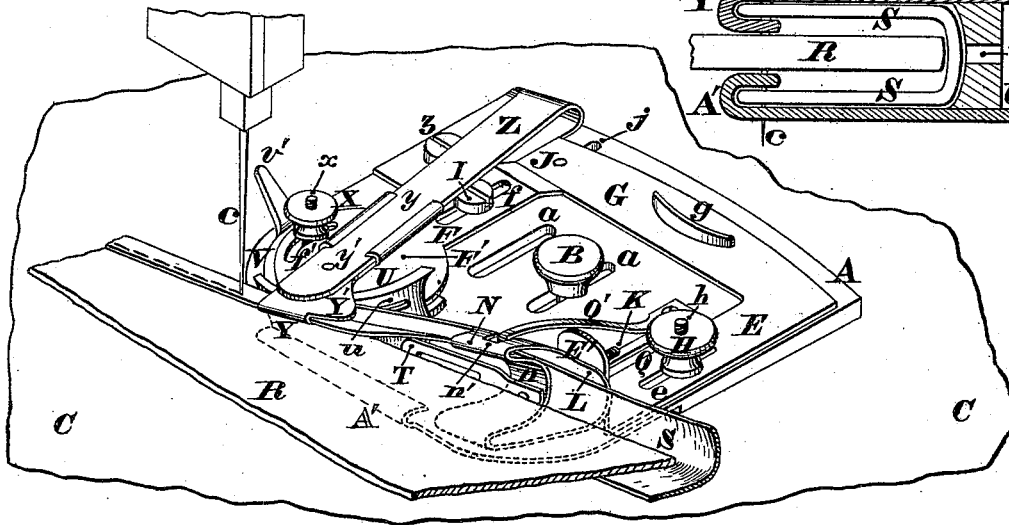

FIG. 7.

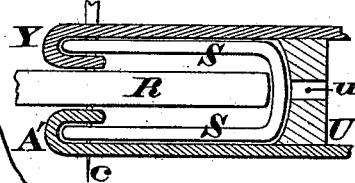

FIG. 2.

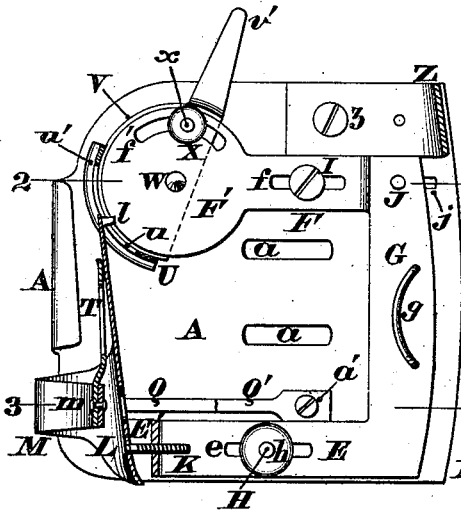

FIG. 3.

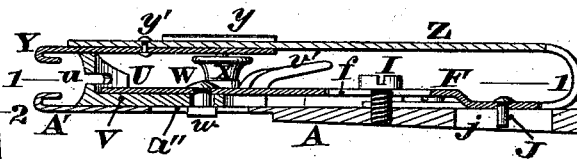

FIG. 4.

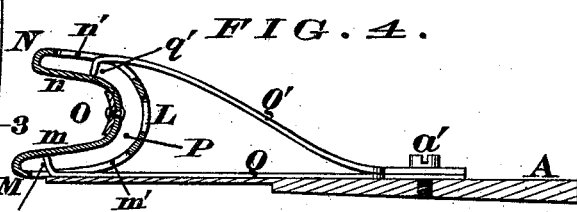

FIG. 5.

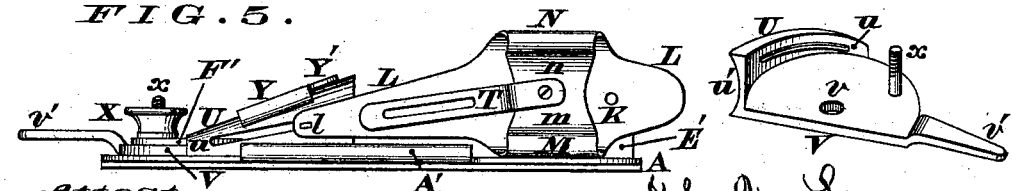

FIG. 6.

Attest.  
Chas. J. Sobel

John Van Leunen  
Per Knight Bros. Att'ys

J. VAN LEUNEN.  
SEWING-MACHINE BINDERS.

No. 180,177.

Patented July 25, 1876.

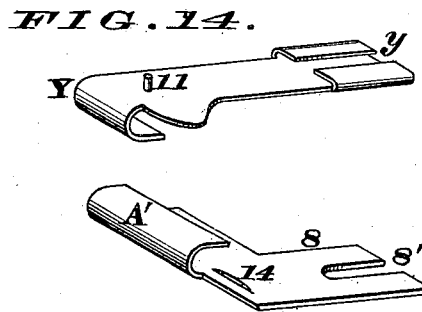
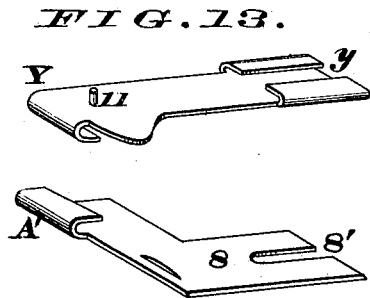
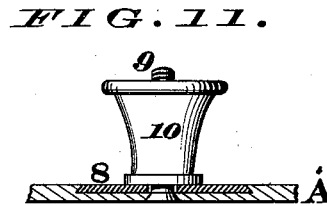
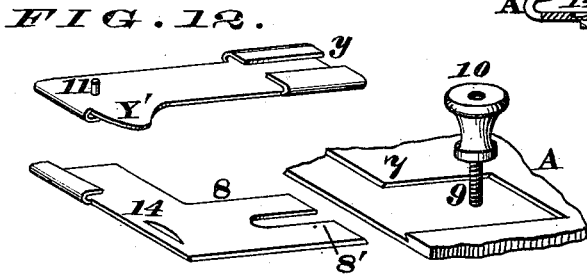
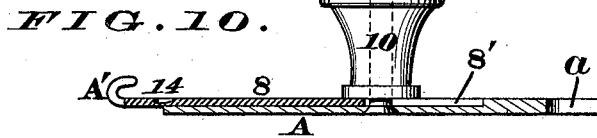
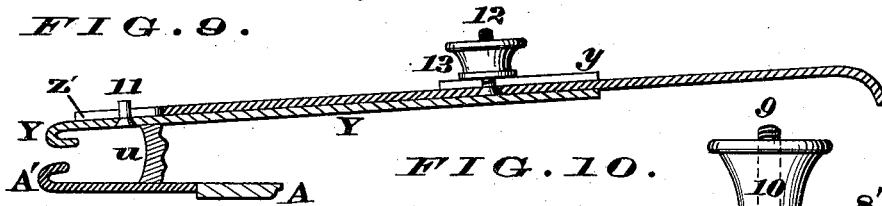
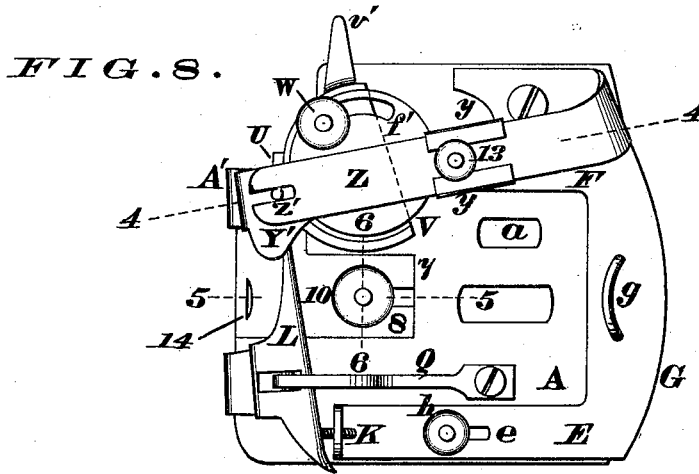

Attest.  
Fred. H. Seymour,  
Chas. J. Coche

John Van Leunen  
Van Klucher Post-Att'ys.

# UNITED STATES PATENT OFFICE

JOHN VAN LEUNEN, OF COVINGTON, KENTUCKY.

## IMPROVEMENT IN SEWING-MACHINE BINDERS.

Specification forming part of Letters Patent No. **180,177**, dated July 25, 1876; application filed November 6, 1875.

*To all whom it may concern:*

Be it known that I, JOHN VAN LEUNEN, of Covington, in the county of Kenton and State of Kentucky, have invented a new and useful Binder Attachment for Sewing-Machines, of which the following is a specification:

My invention relates to a binder which is capable of being used upon any sewing-machine, and of being readily adjusted to suit various thicknesses of fabrics and widths of binding without detaching the implement from the cloth-plate, said adjustments being easily effected by manipulating a couple of set-screws and a regulating-cam, as hereinafter more fully explained. Furthermore, the binder is constructed with detachable edge-turners, that are capable of being adjusted at will, and without removing the implement from the cloth-plate of the sewing machine.

By thus rendering these devices detachable I am enabled to use the various sized edge-turners for different thicknesses of tapes, by which arrangement the action of the binder is rendered more easy and perfect, as there is no crowding of the goods in attempting to feed a heavy fabric through a comparatively contracted space. This act of adjusting, or of detaching, or of applying the edge-turners, is accomplished in a few moments by means of two set-screws, as will presently appear.

In the accompanying drawing, Figure 1 is a perspective view of my binder, attached to the cloth-plate of a sewing-machine, the implement being set to bind a narrow tape upon a thin piece of goods. Fig. 2 is a horizontal section of the binder detached from the cloth-plate, the section being taken at the line 1 1 of Fig. 2. Fig. 3 is a vertical section through the binder at the line 2 2 of Fig. 3. Fig. 4 is another vertical section at the line 3 3 of Fig. 2. Fig. 5 is an elevation of the guiding-scroll and its accessories. Fig. 6 is a perspective view of the regulating-cam detached from the binder. Fig. 7 is a vertical section, showing the manner of binding a broad tape upon a thick piece of goods. Fig. 8 is a plan of that form of my binder in which the adjustable and detachable edge-turners are employed. Fig. 9 is a section at the line 4 4 of Fig. 8, the upper edge-turner being shown shifted toward

the regulating-cam. Fig. 10 is a section at the line 5 5 of Fig. 8. Fig. 11 is a section at the line 6 6 of Fig. 8. Fig. 12 is a perspective view, showing a portion of the bed-plate of the binder, with the two edge-turners detached therefrom. Fig. 13 is a perspective view of two edge-turners adapted for use with a thicker piece of tape. Fig. 14 is a perspective view of two edge-turners of still greater capacity, the upper one being shown as adjusted outwardly from the lower one.

The supporting member of my binder consists of a flat metallic plate, A, provided with one or more slots, *a*, for the reception of a set-screw, B, wherewith the binder is secured to the cloth-plate C of any sewing-machine, and in such manner as to bring the needle *c* in close proximity to the delivering ends of the edge-turners, that will be presently described.

Resting upon the bed-plate A, and capable of being adjusted at will, is a frame, consisting of two parallel bars, E and F, of which the one E is the most remote from the needle *c*. The rear ends of these bars are united by a bar, G, having a rib or flange, *g*, projecting from it, said rib being designed to facilitate the shifting of the frame E F G.

The bar E is slotted at *e* to receive a screw, H, that projects vertically from the bed-plate A, and carries a thumb-nut, *h*. The opposite bar F is slotted at *f* to receive a screw, I, which serves as a guide to the frame E F G. Furthermore, said frame is furnished with a pin, J, that traverses a slot, *j*, in the bed-plate A.

The aforesaid arrangement of slots, screws, and pins confines the shiftable frame E F G to its proper path toward and from the binding-scroll whenever it is being adjusted, and, after said frame has been properly set, it is secured in position by tightening the nut *h*.

The bar E has a vertical projection, E', to which is adjustably secured, by a screw, K, the receiving end of guiding-scroll L, which gradually tapers toward its delivery end, as more clearly shown in Fig. 5. This scroll is provided with two outwardly-projecting lips, M N, which are bent toward each other, and then recurved respectively at *m n*, so as to produce a concave channel, O, and an annular passage, P, of which the channel O serves as

a guide to the edge of the fabric R, while the passage P conducts the binding-tape S in a proper path.

Secured at the junction of the two recurved lips, *m n*, is a tongue, T, which acts as a tension device to maintain the tape S in its proper central position within the scroll L; and said tongue also prevents the tape becoming wrinkled on its passage through the binder.

The lips of the scroll are slotted, respectively, at *m' n'*, to receive blades Q Q', whose fixed ends are attached to the bed-plate A by screw *a'*, the free ends of said blades being furnished with inwardly-projecting fingers *q q'*, that serve as guides for the edges of the tape S when it first enters the binder. These blades are elastic enough to yield when the scroll is adjusted in either direction.

Projecting rearwardly from the delivery end of scroll L is a stud or stump, *l*, which traverses a slot, *u*, in the marginal flange *u* of a semicircular plate, V. This flange gradually increases in height from right to left as it winds around the plate V, so as to form a helical cam, and the exposed face of said cam is connected at *w*, to allow a free passage of the fabric and binding-tape.

The flanged segmental disk V is provided with a central aperture, *v*, for the reception of a pivot-bolt, W, wherewith said disk is coupled to the circular enlargement F' of bar F. The pivot W has a non-circular shank, *w*, that traverses a slot, *a''*, in the plate A. Furthermore, this disk is furnished with a handle, *v'*, wherewith said disk may be rotated in either direction upon its pivot W. Projecting from said disk or helical cam is a screw-threaded stem, *x*, which, after passing through a slot, *f'*, in enlargement F', has a nut, X, engaged with it, which serves to maintain said cam immovably to its adjustment. The aforesaid slot *f'* is concentric with the pivot of the disk.

Y represents the upper edge-turner, its flat expansion Y' projecting toward the scroll L. This edge-turner is attached to a spring-bar, Z, by means of clips *y* and rivet *y'*, which arrangement enables a new edge-turner to be applied to the binder without in any way interfering with the attachment Z. The bar Z is secured to the bed-plate A by means of a screw, *z*.

A' represents the lower edge-turner, which device is simply a prolongation of the bed-plate A, as fully shown in Fig. 3.

In order to render both the upper and lower edge-turners adjustable and detachable, I prefer to construct the binder as represented in Fig. 8, which shows an undercut recess, 7, in the bed-plate A, to receive the dovetailed shank 8 of lower edge-turner A'. This shank is slotted at 8', said slot being traversed by a screw, 9, which projects rigidly from the plate A.

10 is a nut, which, being engaged with the screw 9, serves to maintain the shank 8 securely

in the undercut recess 7. By simply slackening the nut 10, as shown in Fig. 12, the edge-turner can be detached from the binder, and a larger or smaller one substituted in its place.

The upper edge-turner is rendered adjustable and detachable in the following manner: Said device Y has projecting from it a stump, 11, which traverses a longitudinal slot, *z'*, of spring-bar Z, this slot being long enough to allow the edge-turner Y to be shifted as far as may be necessary for all purposes.

Rigidly secured to bar Z, and projecting upwardly therefrom, is a screw, 12, carrying a nut, 13, which latter, when screwed down upon the clips *y*, prevents any accidental shifting of the upper edge-turner.

By referring to Figs. 12, 13, and 14 it will be noticed that the respective pairs of edge-turners are of an increased capacity, the ones shown in Fig. 12 being adapted for use with very thin tape, while the device represented in Fig. 14 is capable of operating upon the thickest tape that can be employed with the binder.

Fig. 13 represents a pair of edge-turners that are to be employed with a tape of medium thickness.

As many intermediate pairs of detachable edge-turners may be employed as may be preferred, although three or four different sizes will generally be sufficient for all ordinary purposes.

After having selected the proper-sized edge-turners for the tape that is to be bound to the fabric, the lower one A' has its tongue 8 inserted in the recess 7, and then secured immovably in position with the nut 10. The clips *y* of the upper edge-turner Y are then slipped along the spring-bar Z, and the stump 11 is inserted in the slot *z'*. The nut 13 is then brought to bear upon said clips, so as to prevent the device Y *y* being accidentally shifted in either direction longitudinally of the supporting-bar Z.

The shifting of the upper edge-turner can be accomplished without detaching the binder from the machine, or removing the goods from the binder.

It is evident that a great saving of time is effected by the use of my implement.

These adjusting devices being so simple and accessible, they can be manipulated with the utmost facility by the women who run the machine.

A nick, 14, in the lower member A' enables the latter to be readily withdrawn from its socket as soon as the nut 10 is unslackened.

The manner of adjusting and operating my binder is as follows: If it should be desired to attach a narrow binding, for example, to a thin piece of goods, as shown in Fig. 1, the sliding frame E F G is first shifted so as to bring the scroll L and the adjusting devices U V X sufficiently near the front edge of the binder, after which the said frame is secured

by tightening the nut *h*. The handle *v'* of disk *V* is then swung toward the needle *e*, which act causes the free end of the spring-bar *Z*, with its attachment *Y Y'*, to approach the lower edge-turner *A'*, and as soon as these devices *Y, Y'*, and *A'* have been brought into sufficient proximity, the nut *X* is screwed down so as to prevent any further rotation of the regulating disk or cam *V*. The tape *S* is then passed through the annular space *P* of the scroll *L*, with the edges of the binding material resting against the fingers *q q'*, and said tape is carried forward between the tongue *T* and the scroll *L*. The edges of the tape are now properly bent over by means of the edge-turners *A' Y*, and the fabric *R* is then inserted in the channel *O* formed by the recurved members *m n* of the scroll. The sewing-machine is now set in motion, and, as the cloth is fed along, the tape is folded down smoothly and uniformly by the action of the edge-turners *A' Y'*, and securely stitched to the fabric *R*, the flat extension *Y'* serving to lay the tape perfectly level before it enters the turner *Y*.

If it should be desired to operate upon thicker goods, the handle *v'* is swung to the right or away from the needle so as to bring a more elevated portion of the helical cam *U* to bear beneath the spring-bar *Z*, and consequently the distance between the edge-turners *A'* and *Y Y'* is increased accordingly. It will thus be seen that the space between the stitching and the curved edge of the binding is regulated by simply shifting the sliding frame *E F G* toward or away from the needle, while greater or less clearance between the binders *A'* and *Y Y'* is obtained by a proper manipulation of the handle *v'*.

As both of these operations can be effected in a few minutes without removing the device from the sewing-machine, my binder will be found to be much more readily manipulated and less liable to derangement than those in general use. The adjustment of the edge-turners *A'* and *Y* being wholly simultaneous, it follows that the two nuts *h* and *X* are all the appliances that require regulating, no

matter how thick or how thin the fabric is, or how wide or narrow may be the binding.

The scroll *L M N* and regulating-cam *U u V v* being both attached to the same sliding frame *E F G*, it will be understood that they have a simultaneous movement toward or away from the needle, and therefore the scroll cannot lose its proper relative distance from the adjusting-cam.

The stud *l*, traversing the bisecting slot *u* in the helical flange of the regulating-cam, operates to maintain the tongue *T* and the scroll *M N* precisely in alignment with the edge-turners *A' Y* at every adjustment of the latter.

What I claim as new, and desire to secure by Letters Patent, is—

1. In combination with the bed-plate *A* and its attached edge-turners *A'* and *Y*, the shiftable-frame *E e H h F f f' I G*, carrying the scroll *L l O P* and the regulating helical cam *U u V v W X x*, as and for the purpose specified.

2. The combination of scroll *L M N O P*, tongue *T*, stud *l*, and the helical cam *U V*, provided with the slot *u*, as and for the objects set forth.

3. In combination with the fixed bed-plate *A* and its attached blades *Q q Q' q'*, the adjustable scroll *L M m m' N n n' O P* for guiding the fabric and tension tongue *T*, all constructed and arranged substantially as herein described and set forth.

4. The combination of spring-bar *Z z' 12 13* and adjustable edge-turners *11 Y y*, as stated.

5. In a sewing-machine binding attachment, the combination of edge-turners to turn the edges of the binding, with a connected folder and back-guide for the binding, said folder and back-guide being adapted to slide toward and from the edge-turners for parallel adjustment, substantially as described.

In testimony of which invention I hereunto set my hand.

JOHN VAN LEUNEN.

Attest:

GEO. H. KNIGHT,  
PETER VAN LEUNEN.