

S. L. BIGNALL, T. B. WHITTLESEY & F. M. GOODHUE.

BRAKES FOR WIND-MILLS.

No. 180,189.

Patented July 25, 1876.

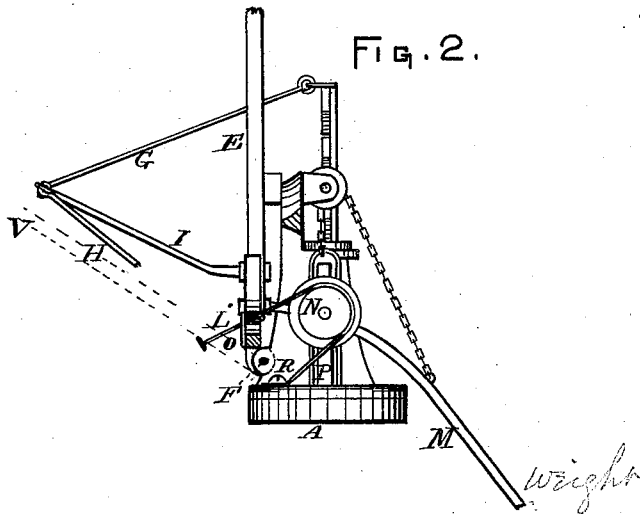
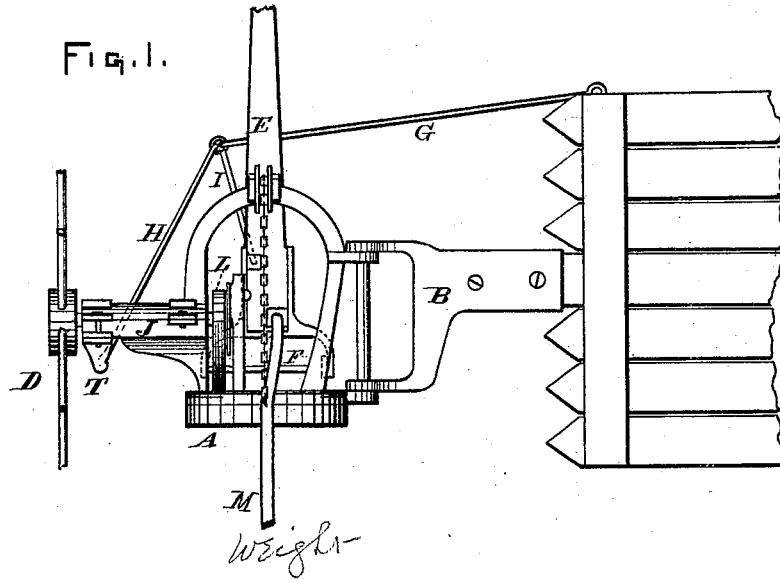

ATTEST
C. H. Adix
A. R. Hilliston.

INVENTOR
Solomon L. Bignall,
Thomas B. Whittlesey,
Frank M. Goodhue.
By *G. H. Schapin*
Atty.

UNITED STATES PATENT OFFICE.

SOLOMON L. BIGNALL, OF CHICAGO, AND THOMAS B. WHITTLESEY AND
FRANK M. GOODHUE, OF ST. CHARLES, ILLINOIS.

IMPROVEMENT IN BRAKES FOR WINDMILLS.

Specification forming part of Letters Patent No. **180,189**, dated July 25, 1876; application filed
May 8, 1876.

To all whom it may concern:

Be it known that we, SOLOMON L. BIGNALL, of Chicago, county of Cook, and THOMAS B. WHITTLESEY and FRANK M. GOODHUE, of St. Charles, in the county of Kane, and State of Illinois, have invented a new and useful Improvement in Brakes for Windmills, of which the following is a specification:

The present invention relates to devices attached to a windmill for automatically controlling the movement of the wind-wheel; and its nature consists in a metal strap or band attached to the turn-table, and brought over the pitman-wheel and extended through the arm of the rotary upright vane, whereby, when the said vane is brought down by the wind, so as to turn the wind-wheel edgewise into the wind, the parts will be securely locked, so as to prevent oscillation, as the whole is to be hereinafter fully described and shown.

In the drawings, Figure 1 is a side elevation of a windmill patented to Frank M. Goodhue, April 7, 1874, embodying our improvement; Fig. 2, a section of Fig. 1 on line *x*, looking in the direction of dart *Z*.

A represents the turn-table; B, the tail-vane; D, a broken section of the wind-wheel; J, the shaft; E, the rotating upright vane, and G I H the connecting-rods; M, the weighted lever, and N the crank-wheel, which are constructed substantially like the parts in the patent referred to. To the turn-table A, at B, is attached a metal band-brake, which is brought

over the crank-wheel N, Fig. 2, and extended through the arm E of the upright vane, or through the plate O, attached to the said arm. The outer end of this band is provided with a lug, W, so that when the upright vane E is brought over, as it is in practice, to the position shown by dotted lines V, Fig. 2, it will clamp the brake-band L to the crank-wheel N, and thus stop the rotation of the wind-wheel D, which gives motion to the wheel N by means of a shaft, J, connecting the two wheels in the ordinary manner. The movement of the vane E is such that when the wind slackens away the weighted arm M, attached to the base of the vane E, will bring the vane to an upright position, and thus release the band L, after which it may again bring the wind-wheel D to a stand, when the vane is brought over to a horizontal position.

Brakes have been before used for checking the movement of mechanism; therefore we confine ourselves to the brake as constructed to operate with a windmill.

We claim and desire to secure by Letters Patent of the United States—

The band L, combined with a wheel on shaft J, and rotating upright vane E, as and for the purpose specified.

SOLOMON L. BIGNALL.
THOMAS B. WHITTLESEY.
FRANK M. GOODHUE.

Witnesses:

O. H. ADIX,
G. L. CHAPIN.