

M. DURAND.  
FIRE-ESCAPES.

No. 180,209.

Patented July 25, 1876.

Fig. 1.

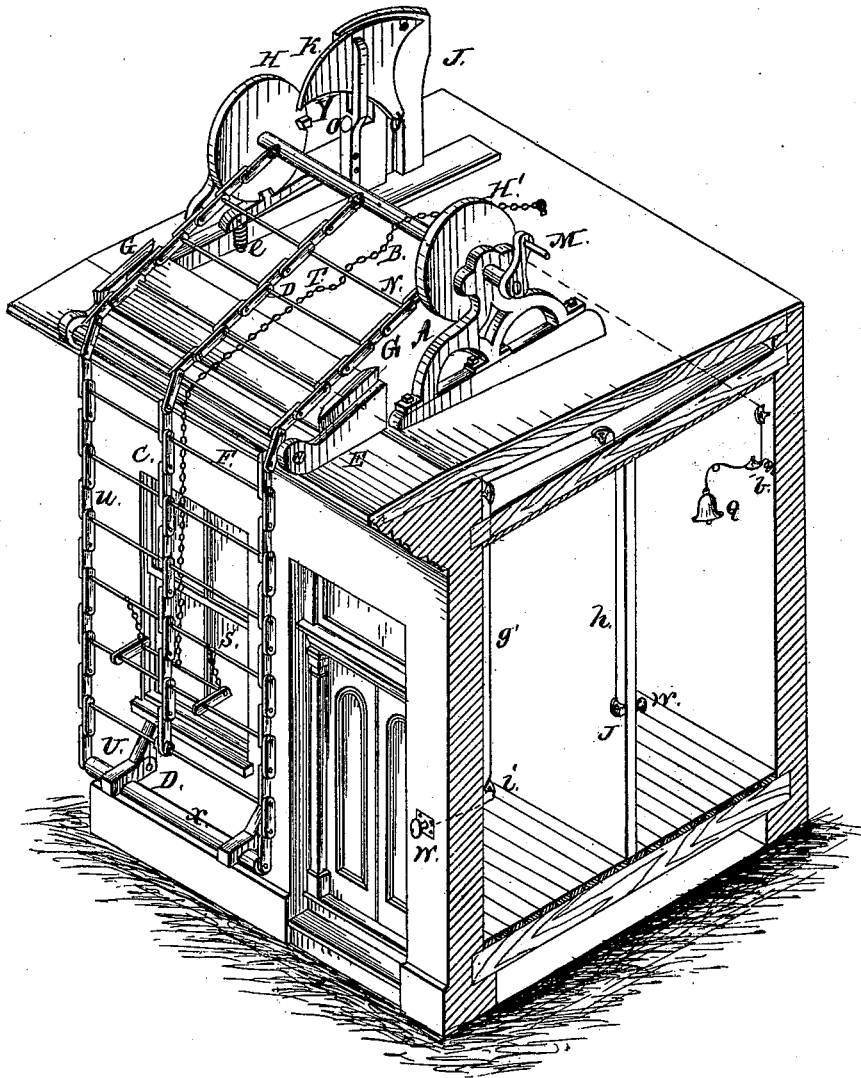

Witnesses:

*Edw. W. Board*  
*W. W. Bay.*

Inventor:

*Michel Durand*  
*by his attorney*  
*Colborne Brooks*

M. DURAND.  
FIRE-ESCAPES.

No. 180,209.

Patented July 25, 1876.

FIG. 3.

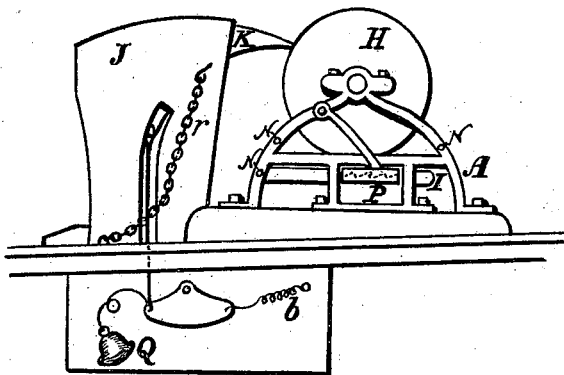

FIG. 2.

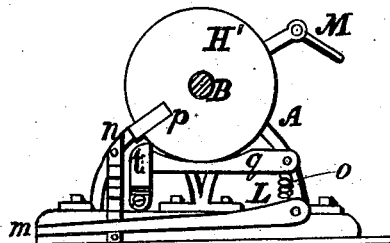

FIG. 4.

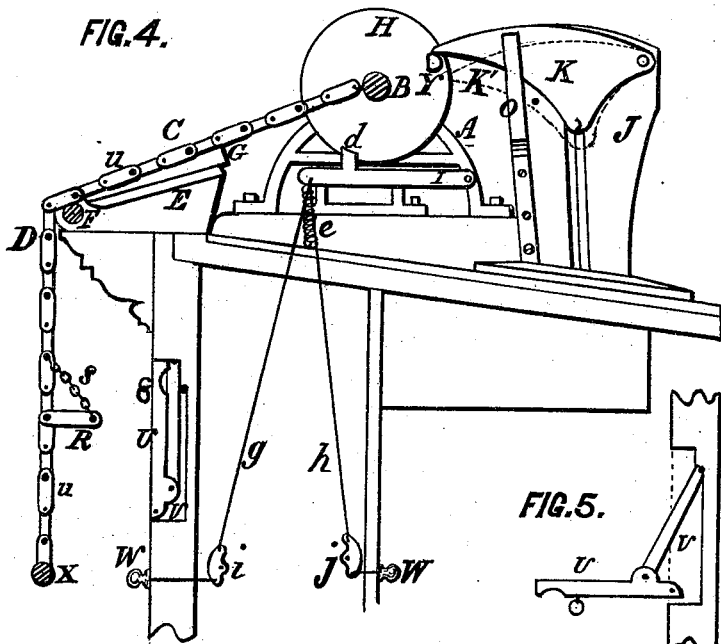
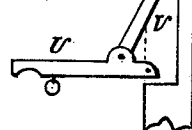

FIG. 5.



WITNESSES

*Edw. M. Davis*  
*J. W. Bay*

INVENTOR,

*Michel Durand*  
by his attorney  
*Colborne Brooks*

# UNITED STATES PATENT OFFICE.

MICHEL DURAND, OF MONTREAL, QUEBEC, CANADA.

## IMPROVEMENT IN FIRE-ESCAPES.

Specification forming part of Letters Patent No. **180,209**, dated July 25, 1876; application filed October 27, 1875.

### *To all whom it may concern:*

Be it known that I, MICHEL DURAND, of the city of Montreal, Province of Quebec and Dominion of Canada, joiner, have invented certain new and useful Improvements in Fire-Escapes, which improvements are fully set forth in the following specification, reference being had to the accompanying drawings.

My invention relates to a fire-escape; and consists in the combination of a fire-alarm apparatus and a fire-ladder in such a manner that when fire is first perceived in a building, any one passing, by pulling a knob-pull (called the "alarm-knob") placed outside said building, will give the alarm to those within, and at the same time will cause a fire-escape ladder to descend from the roof. By these means any one in danger, in whatsoever story he may be, can escape by the window of his room and seize the fire-ladder without waiting for any outside aid. A similar knob is also placed inside the house for the use of the inmates. This apparatus can be placed in the attic of French-roofed houses; but for those having flat roofs it can be put either on or under said roof, or even in the cornice. This fire-ladder can be of any length, and it may have also an extra starting-step opposite the window of every story. The apparatus thus constructed is convenient, simple, and inexpensive.

Figure 1 is a perspective view of the apparatus placed outside on a flat roof. Fig. 2 represents the brake of the drum. Fig. 3 is an exterior sectional view, showing the alarm apparatus. Fig. 4 is an interior sectional view of the apparatus. Fig. 5 represents one of the stagings.

A is a framing bolted to the attic-floor or to the roof, and bearing the drum-shaft and part of the apparatus. B is the drum-shaft, to which the fire-ladder is linked, and on which it is coiled and kept steady by the drum-plates. C is the fire-ladder, made with any number of pivoted plate-links *u* and rounds D. E is an inclined gangway, on which the fire-ladder is placed when stationary, and on which it slides when going down. F is a roller placed in front of the gangway E, to facilitate the descent of the fire ladder and to keep it off the edge of the building-cornice. G G are guards to keep the fire-ladder from swaying. H H'

are the drum plates or wheels, placed at each end of the drum-shaft B, and inside the frames A, and by which the other parts of the apparatus are made to work. I is a detent-bar, having on its outside a box-toothed rack and pawl, P, which keeps down the detent-bar I while the fire-ladder C descends. The detent-bar has a tooth or projection, *d*, meshing in one of the drum-plates H, and a spring, *e*, to keep it out of gear; also, another spring pushing up the detent-bar, in order to mesh its tooth *d* in the notch of the drum-plate H. J is the upright of the rocker. K is the rocker, which communicates, by means of wires and dumping-latches, with the alarm-bell Q. It is worked by a boss, Y, fixed to the inner face of one of the drum-plates H and striking its tip end. L is a brake, by means of which the descent of the fire-ladder is either accelerated or checked. The brake L is composed of the brake-handle *m*, pivoted to the frame A, and connected with the shoe *q* by means of a spring, *o*. *p* is a tooth secured to the drum-head H', for the purpose of acting against and releasing a pivoted link, *t*, which is engaged over the end of the brake-shoe *q*, in order to hold the same out of action during the first revolution of the drum, so that the drum and ladder may attain sufficient momentum to insure the descent of the latter before the brake is applied. *n* is a rack-bar, receiving in one of its notches the free head of the brake-handle *m*, the better to brake the drum B when the fire-ladder descends. M is the crank by which the fire-ladder is coiled around the drum. N are screwed tie-rods binding the two frames A A' together. O is a guide to keep the rocker from parting from the boss Y. R are extra links and starting-steps tied to the fire-ladder by means of the chains S. Such a step may be fixed to the ladder opposite a window on every story.

T is a long chain, holding and securing the extra steps R to the top of the building. This chain passes also over the drum-shaft B, and is fixed in rear of it to the roof. U U are stagings, next the base of the fire-ladder. The stagings have underneath, at their outer end, a concave blank, which is placed over the terminal round X of the fire-ladder to keep it taut and prevent its oscillating; but when

not wanted these stagings are stowed in the niches V V in the wall. The last round X must always be thicker than the others. W is the alarm knob or ring or pull, one or more of which are placed outside the building, and one or more inside. The wires *g h* of the knob are connected with the detent-bar I by means of a sufficient number of dumping-latches, *i j*, spiked to the walls. K' shows the position of the rocker K when out of gear, the boss Y being above it. *b* is a coiled spring to keep the alarm-bell silent. *r* is a chain and pin to lock the rocker when the apparatus is placed in position, or when occasion requires it.

To make use of the apparatus, after it has been placed in position, the fire-ladder is coiled around the drum-shaft B by means of the crank M. The last round X, and the lower part of the ladder C are placed on the inclined gangway E, and the pin *r*, locking down the rocker K, is withdrawn. Thus the rocker becomes free, and comes over the boss Y of the drum-plate H. The tooth of the detent-bar I keeps the apparatus stationary.

As soon as the presence of fire is detected, the first person who perceives it pulls the alarm-knob W. In doing so he brings down the detent-bar I, thus unmeshing its tooth from the drum-plate H. By this simple movement the drum B becomes free and unreels, and as the fire-ladder uncoils itself it slides on the gangway E and comes down by its own weight. In its descent it causes the drum-plate H to revolve, and at each revolution the boss Y raises the rocker K. The rocker then, by means of its wire and latches, rings the alarm-bell Q, which thus warns the inmates of disaster, and awakens them if sleeping.

The descent of the fire-ladder can be accelerated or slackened, as required, by means of the brake L, fixed to the drum-plate H' for that purpose. Although there is but one tooth or projection mitered to the drum-plate H', as shown in the drawings, there may be

as many as required. The degree of friction of the brake L is to be regulated when the apparatus is placed in position. This is effected by inserting the brake-handle *m* in one of the notches of the rack-bar *n*. By these means the velocity required for the steady lowering of the fire-ladder is regulated according to the height of the building.

When the ladder is down the stagings U U are withdrawn from their niches V V, and the blank at the outer end is placed over the last round of the ladder to keep it taut and prevent its oscillating.

There may be as many extra starting-steps as required, and these being an easy and safe approach to the ladder, the descent can be made quickly and without risk.

The alarm-knob can be placed in a box or other suitable place, and any one can open it and sound the alarm at any moment when it becomes necessary to do so.

Having thus described my invention, what I claim is—

1. In combination with the chain ladder C, the folding steps R, sustained by the short chains S.

2. In combination with the fire-ladder C, suspended by the side of a building, as shown, the folding platform U, mounted in the building, and arranged to engage with the ladder.

3. The combination of the drum-head H', provided with the tooth *p* and the brake-shoe *q*, link *t*, and spring *o*, as shown.

4. The brake L, composed of the brake-handle *m*, the rack-bar *n*, the shoe *q*, and mortised block *t*, in combination with a fire-ladder, C, substantially as described.

5. The extra rounds or starting-steps R, the chains S S, and the connecting-chain T, in combination with a fire-ladder, C, substantially as described.

MICHEL DURAND.

Witnesses:

JOSEPH COURSOLLE,  
GRÉGOIRE CLEMENT.