

J. E. HIGGINS.  
BUTTER-TUB.

No. 180,234.

Patented July 25, 1876.

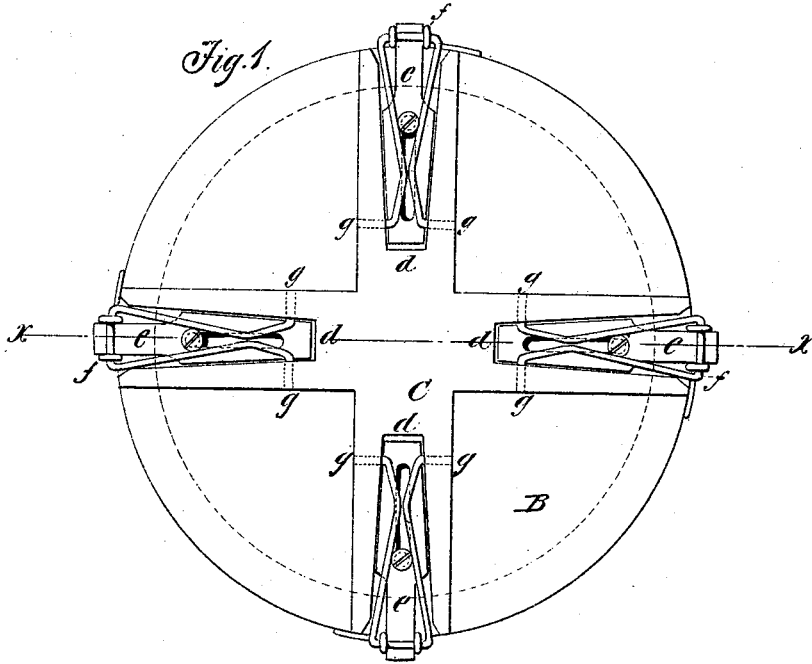
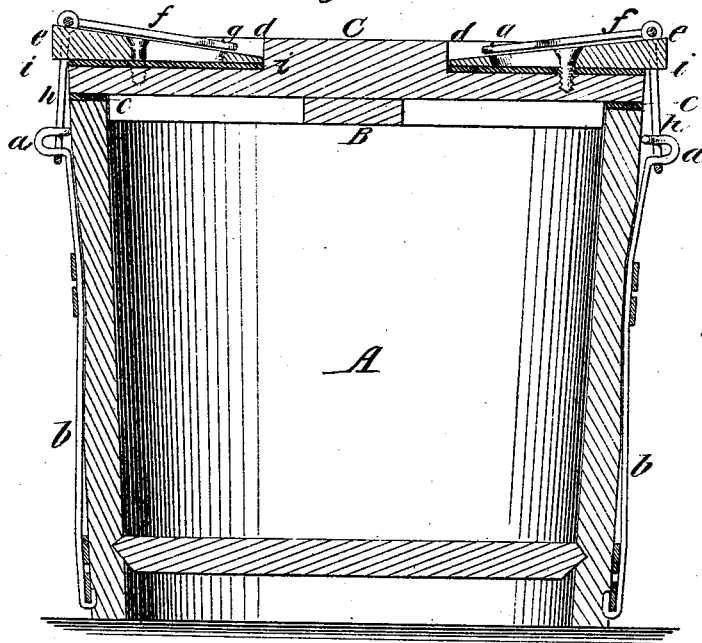

Fig. 2.



WITNESSES:  
*Gustave Ditch*  
*John Goethals*

INVENTOR:  
*J. E. Higgins*  
BY *Wm. L. ...*  
ATTORNEYS.

# UNITED STATES PATENT OFFICE.

JAMES E. HIGGINS, OF HOLLAND CITY, MICHIGAN.

## IMPROVEMENT IN BUTTER-TUBS.

Specification forming part of Letters Patent No. **180,234**, dated July 25, 1876; application filed June 20, 1876.

*To all whom it may concern:*

Be it known that I, J. E. HIGGINS, of Holland City, in the county of Ottawa and State of Michigan, have invented a new and Improved Butter-Tub, of which the following is a specification:

Figure 1 is a top view, and Fig. 2 is a vertical section on line *x x* in Fig. 1.

My invention consists in the combination of devices for fastening the covers of pails, tubs, boxes, and other similar vessels, which are used for packing and transporting articles which require a close package.

A is a tub or pail, which is provided with staples *a*, formed on the ends of draw rods or hooks *b*, which pass inside the upper hoops, and outside the lower hoops, hooking under the lowest one, as shown in Fig. 2. The cover B is provided with a packing-ring, *c*, which makes a tight joint when the cover is pressed down. Two or more cross-bars, C, are attached to the cover, in which recesses *d* are made to receive the wedges *e*. The wedges *e* are slotted, and provided with screws or staples, which retain them in place. *f f* are loops which are placed in the recesses *d*, and pivoted to the cross-bars at *g*, so that their free ends extend just beyond the edge of the cover, in position to engage with the wedges *e*. Hasps or loops *h* are jointed to the loops *f* and are capable of engaging with the staples *a*. Pieces of sheet rubber or packing *i* are placed in the bottom of the recesses *d*.

When it is desired to fasten the cover, the wedges *e* are drawn out as far as possible, and the hasps *h* put over the staples *a*. The wedges *e* are forced in, and by engaging with the loops *f* (they being held by the hasps *h*) drive the cover downward.

This operation not only makes a joint between the cover and the pail or tub; but it also draws on the lower hoop by the hooks *b*. The rubber *i* increases the friction between the wedge and the cover.

Having thus described my invention, what I claim as new and desire to secure by Letters Patent, is—

1. The device herein described for fastening covers to pails, and other similar packages, by means of a jointed hasp attached to the cover, which shuts over a staple in the pail, and a wedge placed between the hasp or loop and cover, substantially as herein shown and described.

2. The combination of the hasp *h*, loop *f*, wedge *e*, and staple *a*, as shown and described.

3. The combination of the hasp *h*, staple *a*, hook *b*, and the ordinary lower hoop of a pail, substantially as shown and described.

JAMES E. HIGGINS.

In presence of—

H. D. POST,

I. A. BERKEMPAS.