

J. W. MILLER.

REIN-HOLDER.

No. 180,256.

Patented July 25, 1876.

Fig. 1.

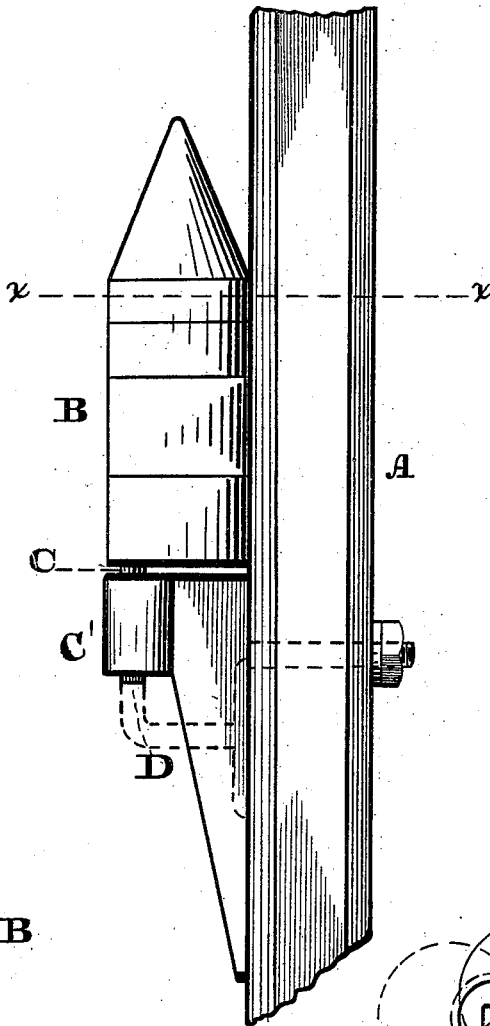

Fig. 2.

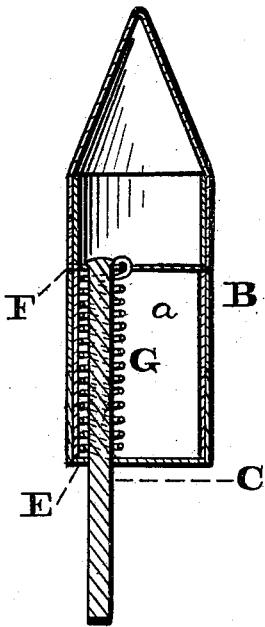

Fig. 5.

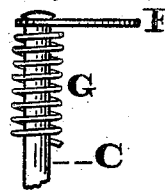

Fig. 4.

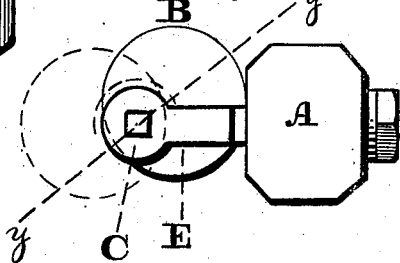
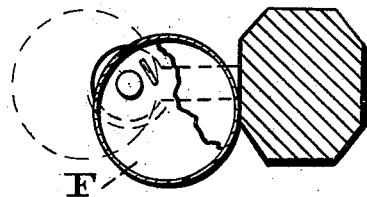

Fig. 3.



Witnesses:  
*Lewis F. Brown,*  
*A. T. Grant.*

Inventor:  
*Jos. W. Miller*  
 by *John M. Wiedenhaus,*  
*att'y.*

# UNITED STATES PATENT OFFICE.

JOSEPH W. MILLER, OF WASHINGTON, PENNSYLVANIA.

## IMPROVEMENT IN REIN-HOLDERS.

Specification forming part of Letters Patent No. **180,256**, dated July 25, 1876; application filed November 27, 1875.

*To all whom it may concern:*

Be it known that I JOSEPH W. MILLER, of Washington borough, in the county of Lancaster and State of Pennsylvania, have invented a new and useful Improvement in Line-Holders; and I do hereby declare the following to be a clear and exact description of the nature thereof, sufficient to enable others skilled in the art to which my invention appertains to fully understand, make, and use the same, reference being had to the accompanying drawings, making part of this specification, in which—

Figure 1 is a side elevation of the device embodying my invention. Fig. 2 is a vertical section thereof in line *yy*, Fig. 4. Fig. 3 is a horizontal section thereof, in line *xx*, Fig. 1. Fig. 4 is a bottom view thereof. Fig. 5 is a side view of a detached part.

Similar letters of reference indicate corresponding parts in the several figures.

My invention consists of a jaw, which is adapted to hold the line against a bar rising from the floor of the vehicle, or an arm on the dasher, or other proper portion of the vehicle, said jaw being mounted eccentric on a spindle, which admits of the regulation of the tension of the spring which faces the jaw to its holding position, the spindle being adjustably fitted to a bracket, whereby the regulation or adjustment of the tension of the spring is accomplished, and the jaw B properly supported.

Referring to the drawings, A represents a bar or arm, which rises from the floor, the dasher, or other proper portion of the vehicle, and constitutes the fixed jaw of the holder. B represents the movable jaw, which extends vertically, and is in the form of a roller, and has a rubber, roughened, or other proper frictional surface. This jaw has its axis on a spindle or pintle, C, fitted eccentric to the jaw, and connected at its lower end D to the bar or arm A by a bracket, C', attached to said bar or arm.

The jaw has a horizontally-extending plate, E, at its lower end, and a similar plate or lug, F, near the upper end, and through the two plates constituting the bearings of

the spindle, and they are separated to provide a space, *a*, in the jaw.

Surrounding the spindle is a spring, G, one end of which is secured to the lower portion of said spindle, and the upper end is connected to the upper plate F, so that when the jaw is rotated the spring will be contracted, and when the jaw is let go the reaction or expansion of the spring will cause the jaw to assume its normal position; consequently, the jaw may be so disposed to the arm or bar A that the jaw will be stopped against said arm or bar, and the power of the spring will be exerted thereagainst.

The upper end of the spindle will be headed, or secured by a pin or otherwise to the upper plate F, and when the parts are in proper position the said upper plate will be soldered or otherwise secured to the inner face of the jaw B.

The bracket C' will have an angular opening for the reception of the end of the spindle C, and the tension of the spring G may be regulated by rotating the spindle the proper number of times, and then inserting the spindle in the bracket, or, if the bracket and spindle are made in one, by securing the end thereof to the bar or arm A.

The tension of the spring may, however, be regulated by rotating the jaw on the spindle, as shown by dotted lines, Figs. 3 and 4, and then affixing the spindle, as in the above case.

It will be seen that when the line is inserted between the fixed and movable jaws, the draft on the line will force the movable jaw tightly against the fixed jaw, owing to the eccentric axis of the former; and the spring G will prevent opening of the jaws, said spring also causing the movable jaw to assume a position ready for application of the line.

In order to properly direct the line to a position between the two jaws, the upper end of the movable jaw will be conical or cut away to form a passage or guide for the line at said end.

I am aware that line-holders have been formed in part of eccentric jaws, and that

springs have been applied thereto ; but I am not aware that any of them have the construction shown and set forth by me.

Having thus described my invention, what I claim as new, and desire to secure by Letters Patent, is—  
The axial spindle C, adjustably fitted to the

bracket C', in combination with the movable jaw B, bearings E F, and spring G, substantially as and for the purpose set forth.

J. W. MILLER.

Witnesses:

JOHN A. WIEDERSHEIM,  
H. E. HINDMARSH.