

H. C. REYNOLDS.

MACHINES FOR WELDING STEEL HEADS ON HATCHETS, &c.

No. 180,270.

Patented July 25, 1876.

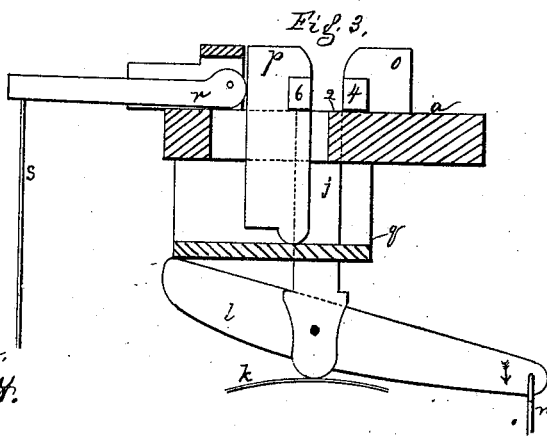
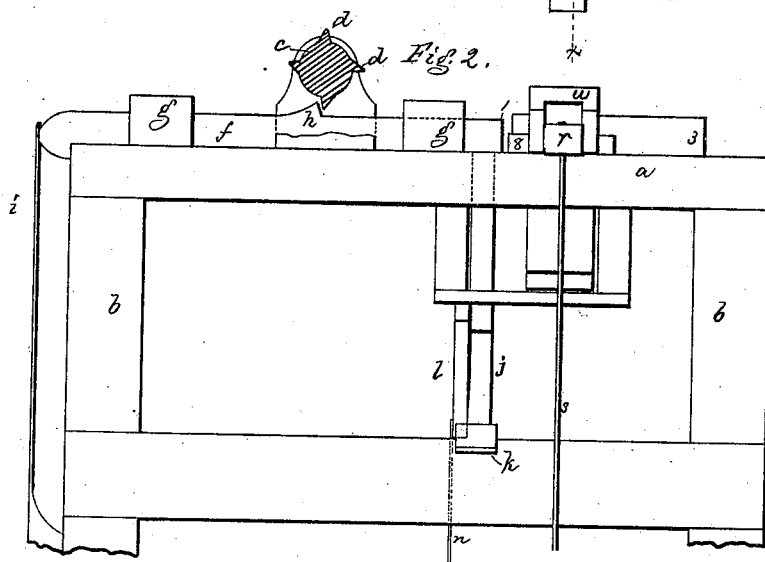
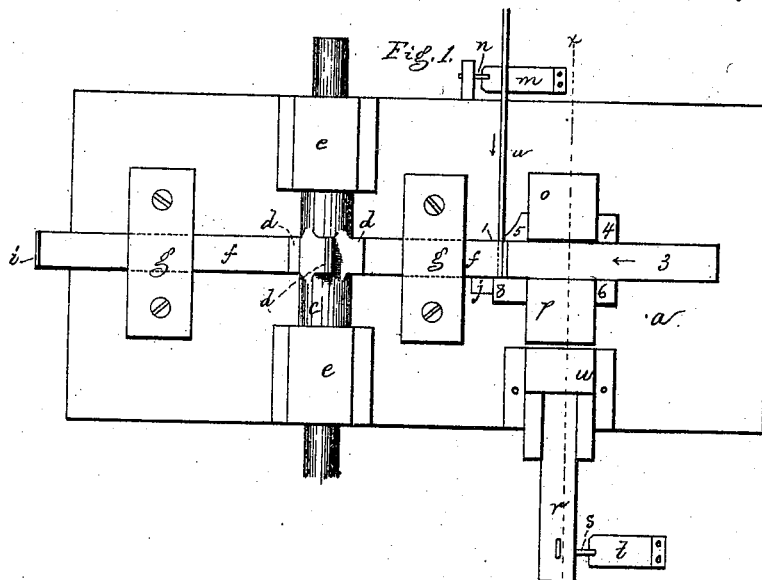

Witnesses.  
L. H. Latimer,  
W. J. Pratt.

Inventor.  
Henry C. Reynolds  
per. George A. Gregory, atty.

# UNITED STATES PATENT OFFICE.

HENRY C. REYNOLDS, OF MANCHESTER, NEW HAMPSHIRE.

IMPROVEMENT IN MACHINES FOR WELDING STEEL HEADS ON HATCHETS, &c.

Specification forming part of Letters Patent No. **180,270**, dated July 25, 1876; application filed May 8, 1876.

*To all whom it may concern:*

Be it known that I, HENRY C. REYNOLDS, of Manchester, in the county of Hillsborough and State of New Hampshire, have invented an Improved Machine for Welding Steel Heads or Faces on Hatchets and other tools, of which the following is a specification:

This invention relates to a machine adapted to weld pieces of steel to pieces of iron in the manufacture of tools, such as hatchets, axes, hammers, &c., to form steel heads for such tools; and the invention consists in the combination, with a support, of jaws for holding the piece of iron to which the steel is to be applied, one jaw being provided with a face or shoulder adapted to bear against the side of the piece of iron, and to serve as a gage for the end of the piece of steel to be welded to the iron, and the other with a cutter to sever the piece of steel projecting from the iron after the completion of the welding process; and also, in connection with the above, is employed a power-hammer and a mechanism for retaining it out of operation.

Figure 1 represents this improved machine, top view; Fig. 2, a side view, with tappet-shaft in section; and Fig. 3, a section on line *x x*, Fig. 1.

The bed or support *a*, on which is placed the material to be welded, is mounted on suitable standards *b b*. The tappet-shaft *c*, provided with tappet *d*, (four being shown,) is sustained in bearings *e*, and is rotated by suitable gearing or belt from any source of power. The hammer-stem *f*, provided at its end 1 with a head of suitable shape, is guided in boxes *g*, and the tappets, acting against the toe *h*, move the hammer-stem away from the material, and a strong spring, *i*, throws it quickly and powerfully against the work when the tappets pass the toe. This hammer-slide may, however, be operated in any usual manner.

The hammer may be retained out of operative position with reference to the revolving tappets by means of a hammer-retainer, *j*, consisting of a bar supported by a spring, *k*, and connected with a lever, *l*, operated by a treadle, *m*, and link *n*. When the hammer is to be operated, the treadle is depressed to move the lever *l* in the direction of the arrow, thereby depressing the retainer *j*, which, when not so

pulled and held down, is by the spring *k* held up above the support *a*, with its end in front of the hammer, the latter being in its backward position.

The piece of iron 3, of proper size and shape, is held between jaws *o p*, the former, in this instance, being stationary, and the latter movable. Jaw *o* is provided with a face, 4, having at its forward end a cutting-edge, 5, and jaw *p* has a face, 6, provided with a shoulder or head, 8, and this jaw, supported in this instance at its lower end on the rest *q*, is moved toward the other jaw *o*, to compress and hold the iron 3, by means of a cam-lever, *r*, connected, by link *s*, with a treadle, *t*. It will be noticed that the head 8 projects farther than the edge of the cutting-edge 5.

The piece of iron 3, sufficiently heated to be welded, is placed on the portion 2 of the support *a*, and between the jaw-faces, and the end of the piece of iron is caused to terminate far enough short of the end 8 of the face 6 to permit the heated end of the piece of steel *u* to meet the side of the head 8, and bear against the end of 3, the head 8 serving as a gage for the end of the steel, and causing it and the end of the iron to meet properly, and in this condition the retainer *j* is moved to release the hammer; and as the piece of iron is held firmly by the jaws, the hammer welds the piece of steel to the piece of iron, and, when welded, the jaws are somewhat released, permitting the hammer to drive the welded iron and steel far enough to cause the steel *u* to be cut by the cutter 5 close to the side of the iron.

In the welding operation, the iron and steel will be prepared in the usual way. The faces 4 6 will be adapted to the shape of the iron to which the steel face or head is to be welded. Heretofore this operation has been performed by hand, the steel in small pieces being welded on the iron, and in some instances the end of a steel bar has been welded to the iron by hand, and then cut by a hand-chisel. By this machine the work can be performed well and quickly.

The bracket *w*, for supporting the cam-lever *r*, is made adjustable with reference to the stationary jaw *o*, to permit the movable jaw *p* to receive between it and the jaw *o* a piece of iron of any desired width.

I claim—

1. The combination, with the hammer and jaws, of the faces 6 4, provided with head 8 and a cutting-edge, to hold the iron and sever the steel when welded, substantially as described.

2. The jaws, and mechanism for actuating them, in combination with the faces 6 4, the former provided with head 8, to serve as a gage for the end of the bar of steel, and the latter with a cutting-edge to sever the steel after welding, substantially as described.

3. The retainer and its operative mechanism, in combination with the hammer and jaws *c p*, provided with faces 4 6, cutting-edge, and head, all substantially as described.

In testimony whereof I have signed my name to this specification in the presence of two subscribing witnesses.

HENRY C. REYNOLDS.

Witnesses:

J. M. MOORE,

THOMAS HAMILTON.